

# Ceiling Diffuser

Type ADLR  
with circular face

Type ADLR-Q  
with square face



**TROX<sup>®</sup> TECHNİK**

TROX GmbH

Heinrich-Trox-Platz  
D-47504 Neukirchen-Vluyn

Telephone +49/28 45/2 02-0  
Telefax +49/28 45/2 02-2 65  
e-mail [trox@trox.de](mailto:trox@trox.de)  
[www.troxtechnik.com](http://www.troxtechnik.com)

# Contents · Description

Description .....	2	Spectral Data .....	6
Quick Selection .....	3	Nomenclature .....	7
Determination of volume flow rate .....	3	Acoustic Data .....	8
Construction · Dimensions .....	4	Aerodynamic Data .....	11
Installation · Assembly · Material .....	5	Order Information .....	14

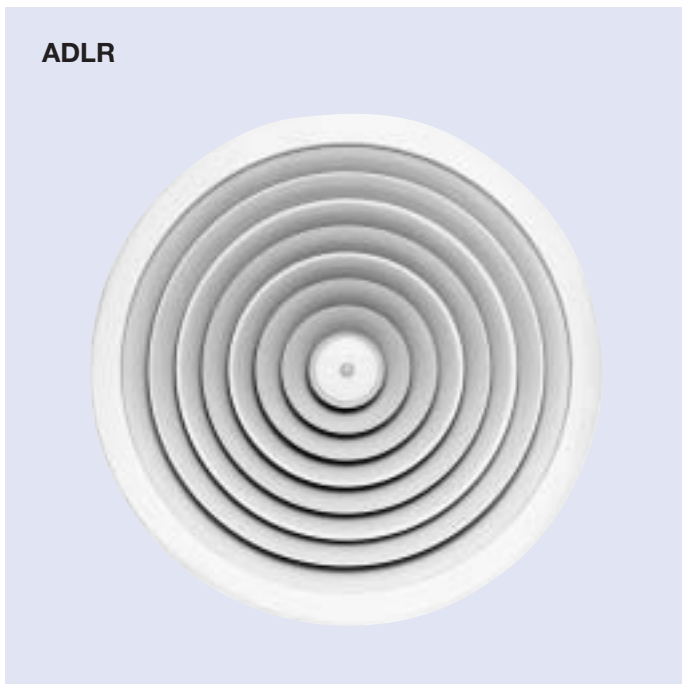

Diffusers Type ADLR and ADLR-Q are recommended for flush installation in ceilings. In this way a 'coander effect' with a radial discharge is guaranteed. Typical supply air volume flows for each size are given in the tables and diagrams. Flush mounting is not absolutely necessary for extract air applications.

Typical supply air temperature differentials lie within the range of +10K to -10K.

Circular (Type ADLR) or square configurations (Type ADLR-Q) can be used in standard ceiling systems. There is no difference between the two constructions with regard to their acoustic and aerodynamic data.

These diffusers can be used for special applications which are not included in the leaflet because there are a large number of possibilities available.

Please contact Trox – together we'll find the solution.

# Quick Selection · Determination of Volume Flow Rate

## Quick Selection

In the quick-selection table below the maximum supply air is set at  $\dot{V}_{\max}$ , such that a sound power level  $L_{WA \max}$  of 40 dB(A) is not exceeded.

At the minimum volume flow given, the discharge velocity will not fall below  $v_{\text{eff}}$  of 2 m/s. This ensures that the "Coanda effect" necessary for a ceiling installation will be achieved.

In commissioning the volume flows per diffuser are important. They must, if necessary, be balanced.

This work is time consuming and can only be undertaken by specialist staff.

Two possibilities for carrying out this work are described in the following:

## Determining the volume flow by means of $v_{\text{eff}}$

The effective discharge velocity  $v_{\text{eff}}$  is measured using a pitot tube. Measurements should be taken evenly and distributed over the diffuser face, the average taken then the flow rate can be calculated from the equation below.

## Determining the volume flow by means of $\Delta p_w$

With the option "MN" (volume flow setting with control cable and test nipple) - see order code, the setting of required flow rates is simplified. The reference pressure  $\Delta p_w$  is measured using a plastic tube ② to a standard manometer.

The relevant volume flow is determined from the characteristic  $\dot{V} = f(\Delta p_w)$  enclosed with every plenum box. If necessary cables ③ and ④ can be used to adjust the butterfly damper in order to obtain the required volume flow. When the measurement and the adjustment have been completed the tube and the cables are pushed behind the diffuser face.

Quick Selection for ADLR · ADLR-Q (Supply air)

Size	$\dot{V}_{\max}$		$\dot{V}_{\min}$		$L_{WA \max}$ dB(A)	$L_{WNC \max}$ NC	$L_{WA \min}$ dB(A)	$L_{WNC \min}$ NC	$A_{\text{eff}}$ m <sup>2</sup>	$R_2$ mm	C mm
	l/s	m <sup>3</sup> /h	l/s	m <sup>3</sup> /h							
1	80	290	20	70	40	31	< 20	< 20	0,0085	192	140
2	120	430	30	110	40	33	< 20	< 20	0,0157	248	196
3	180	650	50	180	40	34	< 20	< 20	0,0257	304	252
4	230	830	80	290	40	35	< 20	< 20	0,0381	360	308
5	300	1080	110	395	40	35	< 20	< 20	0,0536	416	364
6	360	1295	140	505	40	36	< 20	< 20	0,0730	472	420
7	440	1585	180	650	40	37	< 20	< 20	0,0955	528	476
8	500	1800	220	790	40	37	< 20	< 20	0,1150	584	532

## Determining the volume flow by means of $v_{\text{eff}}$

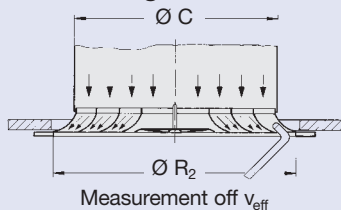

$$\dot{V} = v_{\text{eff}} \cdot A_{\text{eff}} \cdot 1000 \text{ [l/s]}$$

$$\dot{V} = v_{\text{eff}} \cdot A_{\text{eff}} \cdot 3600 \text{ [m}^3\text{/h]}$$

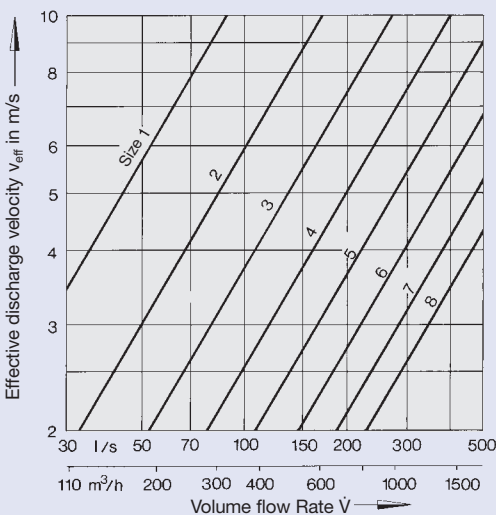

## Determining the volume flow by means of $\Delta p_w$

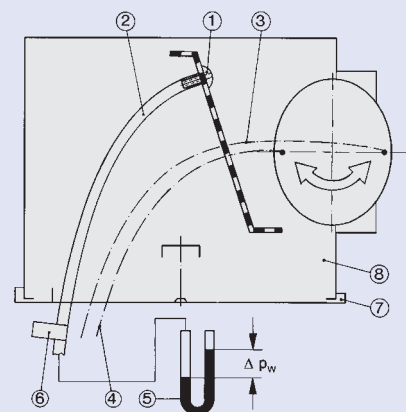

- ① Measurement nipple
- ② Plastic tube
- ③ White sheathed cable (to open butterfly damper)
- ④ Green sheathed cable (to close butterfly damper)
- ⑤ Inclined manometer
- ⑥ Plenum box code
- ⑦ Diffuser face
- ⑧ Plenum box

# Dimensions · Construction

Air diffusers type ADLR can be used for almost all installations. They can be supplied as a diffuser face only, and as a diffuser combined with butterfly damper or mounting ring. The plenum box can be supplied with top or side entry spigot and volume control damper and/or lip seal if required.

For measurement and setting of volume flow the plenum box can be equipped with volume control damper cables and test nipple (see page 3).

Other options are available such as a duct mounting subframe for vertical duct installation.

The diffuser face can be installed or removed via one central screw. The screw head is covered with a decorative cap. The internal design of the extract and supply air plenum boxes are constructed differently to provide optimum acoustic performance.

Size	Ø B	Ø D	H <sub>1</sub>	H <sub>2</sub>	□ K	Ø P	Ø R <sub>1</sub>	Ø R <sub>2</sub>	AK code for side entry spigot
1	201.5	123	233	220	266	202	244	192	AK 019
2	257.5	158	233	250	290	258	300	248	AK 020
3	313.5	198	233	295	372	314	356	304	AK 021
4	369.5	248	267	345	476	362	412	360	AK 022
5	425.5	248	267	345	476	426	468	416	AK 023
6	481.5	313	298	410	567	482	542	472	AK 024
7	537.5	313	298	410	590	578	598	528	AK 025
8	593.5	313	298	410	615	590	654	584	AK 026

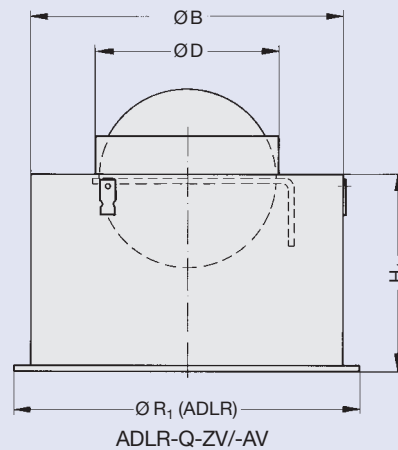
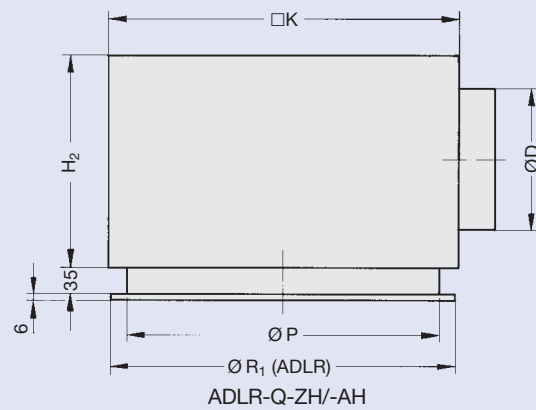
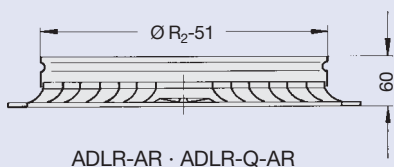
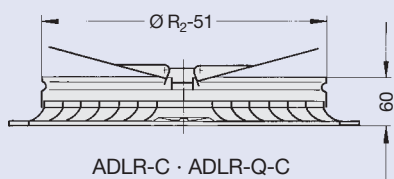
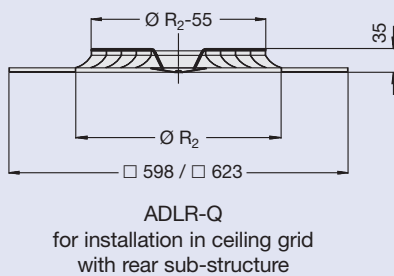
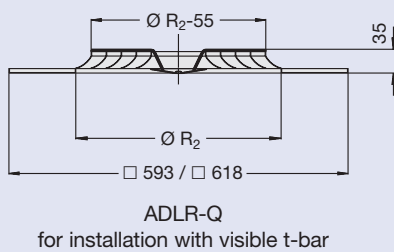
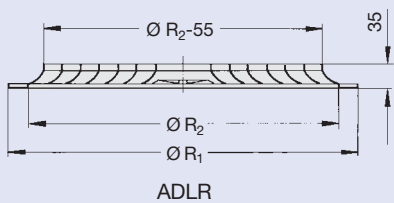

# Installation · Assembly · Materials

## Installation · Assembly

All constructions and sizes are designed for installation in false suspended ceilings. If plenum boxes are used the unit is suspended on wires or slotted strip using the drillings provided, or on straps from the slab.

The diffuser face is fixed by the central screw and the subframe provided. A snap-on cap is provided to cover the screw head.

If a vertical rigid duct is provided on site the diffuser can be fixed by means of a cross bridge and central screw or directly to the neck of the diffuser, e.g. by self tapping screws.

For these types of fixings the ...-AR mounting ring can be used. The following examples show the various types of installation.

## Materials

Deep drawn aluminium diffuser face, rear components in formed sheet steel.

Powder-coated white (RAL 9010) gloss level GL = 50 %.

The surfaces of the rear attachments are phosphate treated and stove enamelled black using an electro-dipping process.

Plenum box of galvanised sheet steel, rubber sealing lip seal.

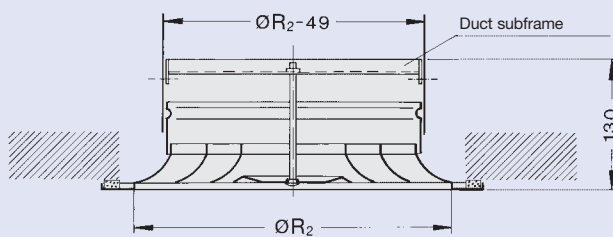

Installation with duct subframe

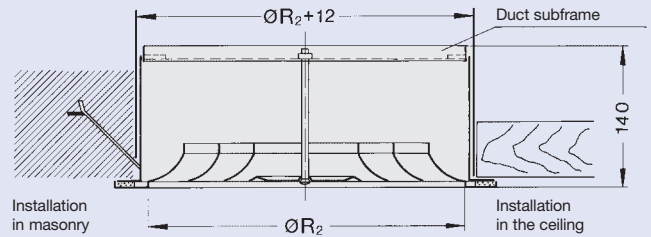

Installation with standard subframe

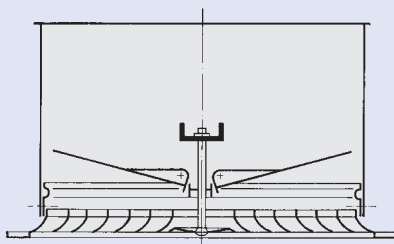

Flap damper with duct subframe in a vertical duct

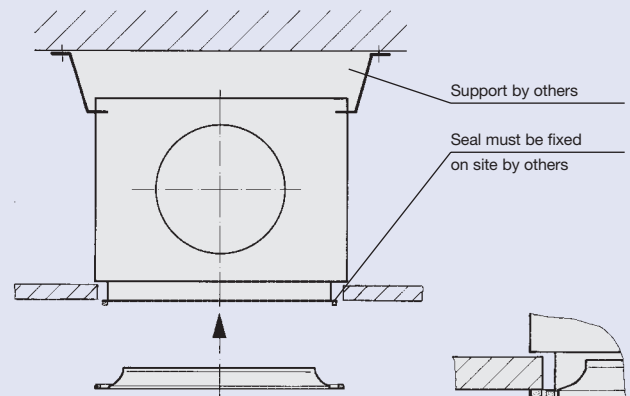

Fixing of diffuser face with central screw

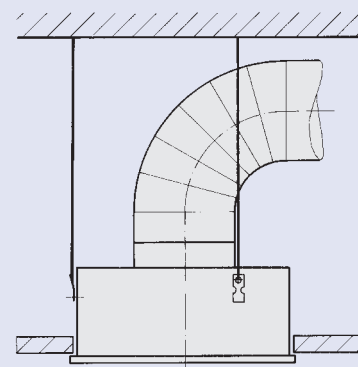

Installation using suspension brackets

# Spectral Data

Relative spectra  $\Delta L$  for blade angle  $0^\circ$

Size	eff. jet velocity	ADLR · ADLR -Q (supply air)								eff. jet velocity	ADLR · ADLR -Q (extract air)							
		Octave band centre frequency in Hz									Octave band centre frequency in Hz							
	$V_{eff}$ m/s	63	125	250	500	1000	2000	4000	8000	$V_{eff}$ m/s	63	125	250	500	1000	2000	4000	8000
1	5	18	3	2	1	-14	-27	-31	-31	5	18	7	3	-3	-9	-14	-19	-23
	7	15	3	1	0	-8	-18	-24	-28	6	16	5	1	-22	-7	-11	-16	-21
	9	12	2	0	-1	-5	-12	-20	-26	7	14	4	0	-3	-6	-9	-14	-20
	12	7	-1	-4	-5	-3	-8	-17	-26	8	12	2	-2	-3	-5	-8	-13	-20
2	4	19	3	1	1	-16	-32	-35	-34	4	17	5	5	-3	-12	-17	-23	-28
	6	16	3	0	1	-9	-21	-26	-29	5	15	4	4	-2	-9	-14	-19	-25
	8	13	2	-1	-1	-5	-14	-21	-27	6	13	2	2	-1	-7	-11	-16	-23
	10	10	0	-3	-3	-3	-10	-19	-27	7	11	0	1	-2	-6	-9	-14	-22
3	4	18	2	-1	1	-13	-30	-33	-34	3	17	3	6	-4	-17	-23	-29	-33
	5	17	2	-1	1	-9	-24	-29	-31	4	15	2	6	-2	-13	-17	-23	-29
	7	13	1	-3	-1	-4	-16	-23	-29	5	13	1	4	-1	-10	-14	-19	-26
	9	9	-1	-6	-3	-2	-12	-20	-29	6	11	-1	3	-1	-8	-11	-16	-25
4	3	20	2	0	1	-19	-39	-40	-38	2.5	11	9	3	0	-12	-25	-38	-36
	4	19	2	0	1	-14	-31	-34	-34	3	11	6	3	0	-10	-21	-33	-33
	5	17	3	0	1	-10	-25	-29	-31	4	11	1	1	0	-7	-15	-26	-30
	7	14	2	-2	0	-5	-16	-23	-28	5	10	-3	-1	-1	-5	-11	-21	-28
5	3	20	1	-2	1	-16	-37	-39	-37	2.5	-12	5	7	-7	-14	-18	-27	-35
	4	18	2	-2	1	-11	-29	-32	-34	3	-5	5	7	-5	-12	-15	-22	-30
	5	16	2	-3	1	-7	-23	-28	-32	4	3	3	4	-2	-8	-11	-16	-25
	7	12	0	-5	-1	-3	-16	-23	-30	5	9	0	1	-1	-7	-9	-13	-21
6	3	19	1	-4	1	-12	-35	-37	-38	2.5	-23	3	8	-9	-15	-18	-27	-37
	4	17	1	-5	1	-7	-27	-31	-34	3	-16	3	7	-6	-12	-14	-23	-32
	5	14	0	-6	0	-4	-22	-28	-33	4	-7	1	5	-3	-9	-10	-16	-26
	7	9	-3	-9	-4	-2	-16	-24	-32	5	-2	-1	2	-2	-7	-8	-13	-22
7	2.5	20	0	-4	1	-15	-40	-41	-40	2.5	11	8	3	-1	-10	-22	-33	-35
	3	19	1	-4	1	-12	-35	-37	-38	3	12	5	3	0	-8	-18	-28	-32
	4	17	1	-5	1	-7	-27	-31	-35	4	11	0	1	-1	-5	-12	-21	-30
	5	14	0	-6	0	-4	-22	-28	-31	5	10	-5	-2	-2	-4	-9	-17	-28
8	2.5	20	1	-4	1	-17	-41	-42	-40	2.5	12	8	3	-1	-10	-21	-32	-34
	3	19	1	-3	1	-14	-36	-38	-38	3	12	5	2	0	-8	-17	-27	-32
	4	17	1	-4	1	-8	-28	-32	-34	4	11	0	0	-1	-5	-12	-20	-29
	5	15	1	-4	0	-5	-22	-28	-32	5	10	-6	-2	-2	-4	-9	-16	-28

# Spectral Data · Nomenclature

## Nomenclature

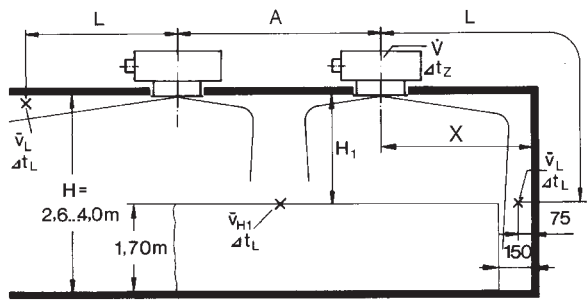

- $A_{\text{eff}}$  in m<sup>2</sup>: Effective area
- $\dot{V}$  in l/s: Volume flow rate per diffuser
- $\dot{V}$  in m<sup>3</sup>/h: Volume flow rate per diffuser
- $A$  in m: Spacing between two diffusers
- $H_1$  in m: Distance between ceiling and occupied zone
- $X$  in m: Distance between centre of diffuser – wall

- $\bar{v}_{H1}$  in m/s: Time average air velocity between two diffusers at distance from ceiling  $H_1$
- $L$  in m: Horizontal + vertical distance ( $X + H_1$ ) discharge to wall
- $\bar{v}_L$  in m/s: Time average air velocity at the wall
- $\Delta t_z$  in K: Temperature difference between supply air and room air
- $\Delta t_L$  in K: Difference between core and room temperature at distance  $L = A/2 + H_1$  or  $L = X + H_1$
- $\Delta p_t$  in Pa: Total pressure drop
- $L_{WA}$  in dB(A): A-weighted sound power level
- $L_{WNC}$ : NC rating of sound power level
- $L_{WNR}$ :  $L_{WNR} = L_{WNC} + 2$
- $\Delta L$  in dB/Oct: Relative sound power level with respect to  $L_{WA}$
- $L_W$  in dB/Oct: Octave sound power level of air regenerated noise  $L_W = L_{WA} + \Delta L$
- $L_{pA}, L_{pNC}$ : A-weighted and NC rating respectively of room sound pressure level
- $L_{pA} \approx L_{WA} - 8 \text{ dB}$
- $L_{pNC} \approx L_{WNC} - 8 \text{ dB}$

### Relative spectra $\Delta L$ for blade angle 0°

Please inquire if required for relative spectra ADLR-ZH · ADLR-Q-ZH!

Size	eff. jet velocity $v_{\text{eff}}$ m/s	ADLR-ZV · ADLR-Q-ZV								eff. jet velocity $v_{\text{eff}}$ m/s	ADLR-AV · ADLR-Q-AV							
		Octave band centre frequency in Hz									Octave band centre frequency in Hz							
		63	125	250	500	1000	2000	4000	8000		63	125	250	500	1000	2000	4000	8000
1	2	4	0	7	-9	-29	-42	-30	-7	4	0	4	6	-3	-9	-18	-21	-25
	4	4	1	7	-4	-15	-27	-24	-12	5	-1	3	5	-3	-7	-15	-18	-29
	6	2	0	6	-3	-8	-19	-22	-17	6	-3	1	4	-3	-6	-12	-16	-32
	8	0	-2	4	-3	-4	-15	-21	-21	7	-4	0	4	-3	-6	-11	-14	-34
2	2	7	2	7	-6	-25	-37	-28	-9	4	10	4	6	-3	-8	-17	-24	-27
	3	7	3	7	-4	-17	-29	-25	-12	5	8	3	5	-3	-7	-14	-21	-30
	5	5	2	5	-2	-8	-19	-22	-17	6	7	2	4	-3	-6	-12	-19	-33
	7	2	-1	2	-2	-4	-14	-21	-23	7	5	1	3	-3	-5	-10	-18	-36
3	2	9	4	7	-5	-22	-34	-27	-10	4	11	4	5	-3	-8	-17	-24	-27
	3	8	4	6	-3	-15	-26	-24	-14	5	9	3		-3	-7	-14	-22	-30
	5	5	2	4	-1	-7	-17	-22	-20	6	8	2	4	-3	-6	-12	-20	-33
	7	2	-1	1	-2	-3	-13	-22	-25	7	6	1	3	-3	-5	-10	-18	-36
4	2	9	4	7	-4	-21	-33	-27	-10	3	0	6	3	0	-10	-20	-28	-33
	3	8	4	6	-2	-14	-25	-24	-14	4	-4	1	2	0	-7	-15	-24	-32
	5	6	2	3	-1	-6	-16	-22	-20	5	-8	-3	1	-1	-5	-12	-21	-31
	7	2	-1	0	-3	-3	-12	-22	-26	6	-11	-6	-1	-2	-4	-10	-19	-32
5	2	12	7	5	-2	-17	-28	-25	-14	2.5	12	5	5	-2	-10	-15	-27	-30
	3	11	6	4	-1	-10	-20	-23	-18	3	9	4	4	-1	-9	-14	-26	-30
	5	6	3	0	-1	-4	-13	-22	-26	4	3	1	3	-1	-7	-14	-24	-31
	7	1	-2	-5	-4	-2	-10	-24	-34	5	-2	-1	2	-1	-6	-14	-23	-31
6	2	12	7	6	-2	-17	-28	-26	-14	2.5	12	5	5	-2	-10	-15	-27	-30
	3	10	6	4	-1	-11	-21	-23	-18	3	8	4	4	-1	-8	-15	-26	-30
	5	6	3	0	-1	-4	-13	-22	-26	4	2	1	3	-1	-7	-15	-24	-30
	7	1	-2	-5	-4	-2	-10	-24	-33	5	-3	-1	2	-1	-5	-11	-23	-31
7	2	14	8	4	-1	-14	-24	-25	-17	2.5	5	9	3	0	-13	-23	-35	-39
	3	12	7	2	0	-8	-17	-23	-22	3	3	6	3	0	-10	-20	-32	-37
	4	9	4	-1	-1	-5	-13	-23	-27	4	-1	2	2	0	-7	-15	-27	-36
	6	3	-1	-6	-3	-2	-10	-25	-35	5	-5	-2	1	-1	-5	-11	-25	-36
8	2	15	9	2	0	-13	-22	-25	-20	2.5	6	9	3	0	-13	-23	-37	-41
	3	12	7	0	0	-7	-15	-23	-25	3	5	7	3	0	-10	-19	-34	-40
	4	9	4	-3	-1	-4	-12	-24	-30	4	1	3	2	0	-7	-14	-30	-39
	6	2	-1	-9	-4	-2	-9	-26	-39	5	-3	-2	1	-1	-5	-11	-27	-38

# Acoustic Data

## Example

Data given:

Type ADLR; size 2

Volume flow per diffuser  $\dot{V} = 80 \text{ l/s}$

Required: Octave sound power level of air regenerated noise  $L_W$

Diagram 4: Sound power level and Pressure drop

$L_{WA} = 25 \text{ dB(A)}$

$\Delta p_t = 17 \text{ Pa}$

Effective jet velocity  $v_{\text{eff}}$ :

$$v_{\text{eff}} = \frac{\dot{V}}{A_{\text{eff}} \cdot 1000} = \frac{80}{0.0157 \cdot 1000} = 5.1 \text{ m/s}$$

Octave centre frequency in Hz	63	125	250	500	1000	2000	4000	8000
$L_{WA}$ in dB(A)	25	25	25	25	25	25	25	25
$\Delta L$ in dB	+15	+4	+4	-2	-9	-14	-19	-25
$L_W$ in dB	40	29	29	23	16	11	6	0

1 Sound power level and pressure drop  
Type ADLR-ZH · ADLR-Q-ZH

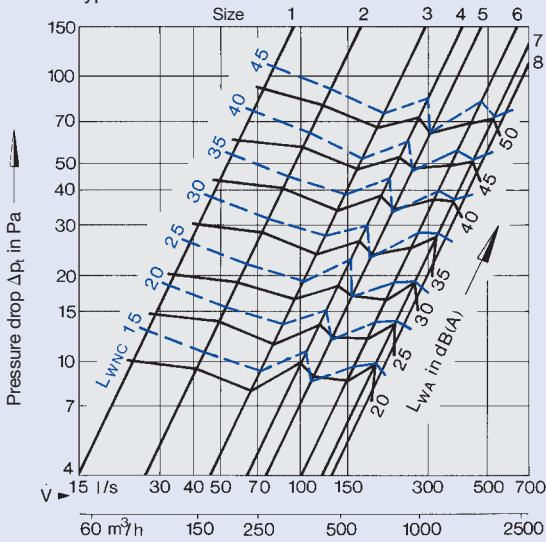

2 Sound power level and pressure drop  
Type ADLR-AH · ADLR-Q-AH

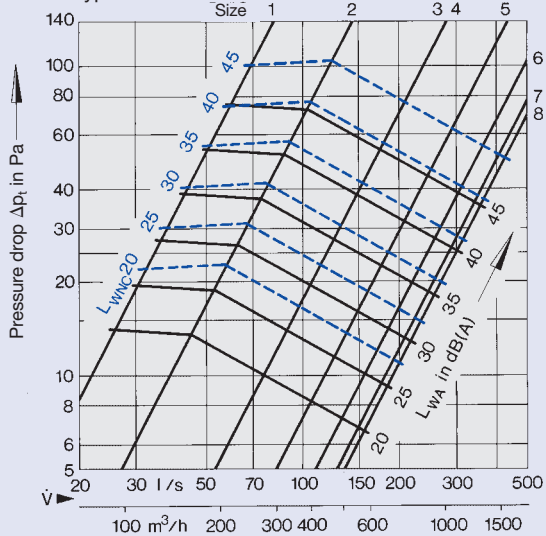

Correction to diagram 1: Air flow control damper position

Size	Damper angle	0°	45°	90°
1	$\Delta p_t$	x 1.0	x 1.3	x 2.9
	$L_{WA}$	-	+1	+5
	$L_{WNC}$	-	+1	+5
2	$\Delta p_t$	x 1.0	x 1.3	x 3.1
	$L_{WA}$	-	+2	+7
	$L_{WNC}$	-	+2	+7
3	$\Delta p_t$	x 1.0	x 1.4	x 4.0
	$L_{WA}$	-	+3	+7
	$L_{WNC}$	-	+3	+7
4	$\Delta p_t$	x 1.0	x 1.2	x 3.6
	$L_{WA}$	-	+1	+8
	$L_{WNC}$	-	+1	+8
5	$\Delta p_t$	x 1.0	x 1.5	x 4.3
	$L_{WA}$	-	+3	+13
	$L_{WNC}$	-	+3	+13
6	$\Delta p_t$	x 1.0	x 1.4	x 3.6
	$L_{WA}$	-	+2	+6
	$L_{WNC}$	-	+2	+6
7	$\Delta p_t$	x 1.0	x 1.4	x 3.8
	$L_{WA}$	-	+4	+14
	$L_{WNC}$	-	+4	+14
8	$\Delta p_t$	x 1.0	x 1.5	x 3.8
	$L_{WA}$	-	+4	+11
	$L_{WNC}$	-	+4	+11

# Acoustic Data

## Correction to diagram 5: Air flow control damper position

With straight duct on to top entry plenum spigot

Size	Damper angle	0°	45°	90°
1 - 8	$\Delta p_t$	x 1.0	x 1.2	x 3.3
	$L_{WA}$	-	+ 3	+ 7
	$L_{WNC}$	-	+ 3	+ 7

Duct with 90° bend on to top entry plenum spigot

Size	Damper angle	0°	45°	90°
1 - 8	$\Delta p_t$	x 1.2	x 1.5	x 3.1
	$L_{WA}$	+ 3	+ 5	+ 10
	$L_{WNC}$	+ 3	+ 5	+ 10

**3** Sound power level and pressure drop  
Supply air type ADLR · ADLR-Q

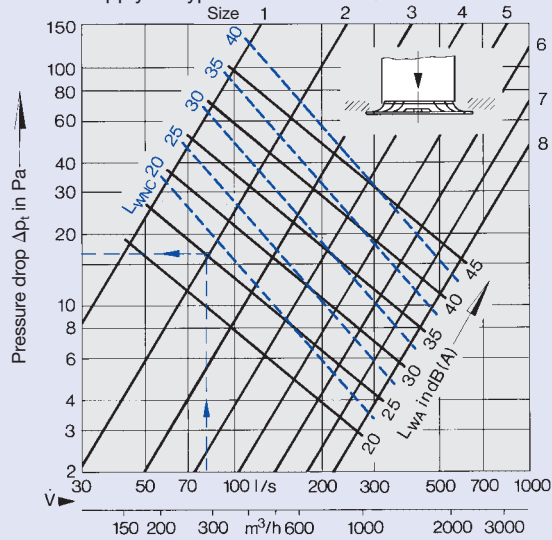

**5** Sound power level and pressure drop  
Type ADLR-ZV · ADLR-Q-ZV

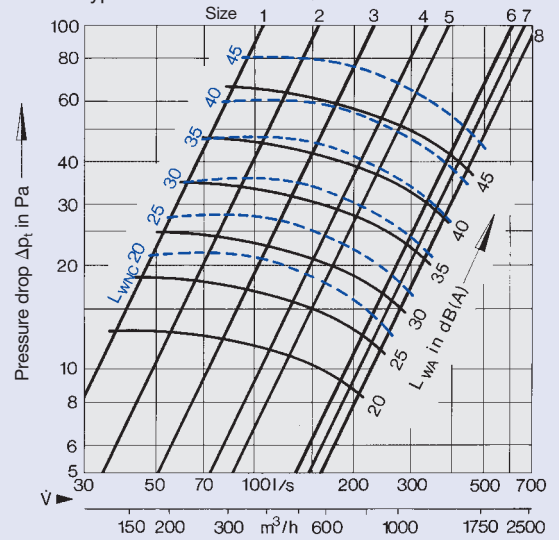

**4** Sound power level and pressure drop  
Extract air type ADLR · ADLR-Q

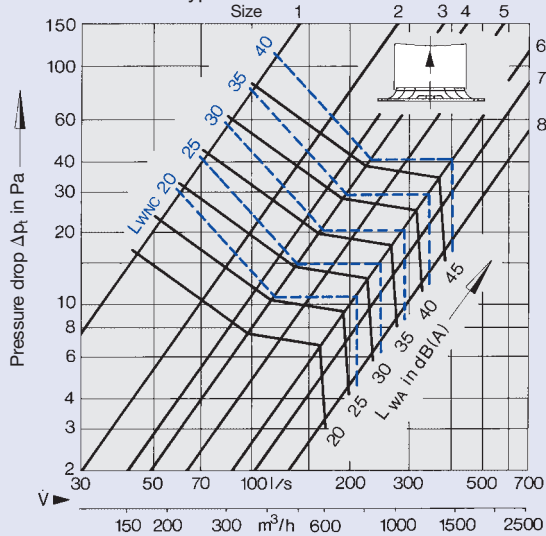

**6** Sound power level and pressure drop  
Type ADLR-AV · ADLR-Q-AV

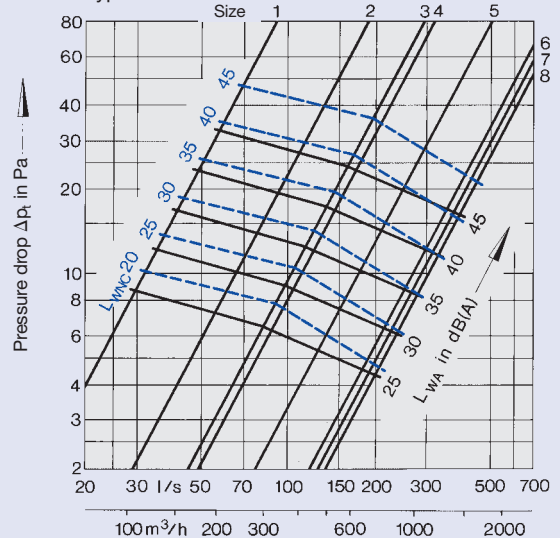

# Acoustic Data

## Example

A room is to be fitted with diffusers type ADLR. There is a circular duct in the centre of the ceiling void, so that a vertical flow ADLR diffuser face is required. The duct is low velocity ( $v \approx 3.0$  m/s)

Given:

Room dimensions:  $B \times L \times H = 4.0 \times 5.0 \times 3.0$  m  
 Max. volume flow rate:  $\dot{V} = 140$  l/s  
 Pressure range:  $\Delta p_t = 15 - 25$  Pa  
 Supply air temperature differential:  $\Delta t_z = -8$  K  
 Room noise level required:  $= 30$  dB(A)  
 Room noise attenuation:  $= 6$  dB(A)

Solution:

Because the duct pressures can vary between 15 and 25 Pa, a damper is required.  
 As it is a low velocity duct, a flap type damper is selected.

Ceiling diffuser type DLR-C selected.

Quantity: 2 positioned along the length of the room  
 at interval  $A = 2.0$  m

This gives a volume flow rate per diffuser of  
 $\dot{V} = 140/2 = 70$  l/s

A calculation gives size 2  
 (diagrams 12 and 7).

Diagram 7:	Sound power level and Pressure drop	
Sound power level $L_{WA}$	=	25 dB(A)
Level increase for 2 diffusers	+	3
		<hr/> 28 dB(A)
Correction from table at 50 % open	+	8 dB(A)
		<hr/> 36 dB(A)
Room attenuation	-	6 dB
Noise level in room		<hr/> <hr/> 30 dB(A)

At  $\Delta p_t = 25$  Pa ( $14 \times 1.7$ ) there is a room noise level of 30 dB(A).

**7** Sound power level and pressure drop  
 Supply air type ADLR-C · ADLR-Q-C

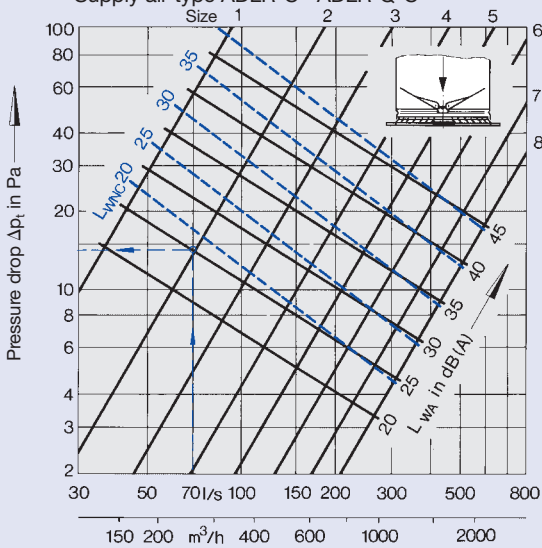

**8** Sound power level and pressure drop  
 Extract air type ADLR-C · ADLR-Q-C

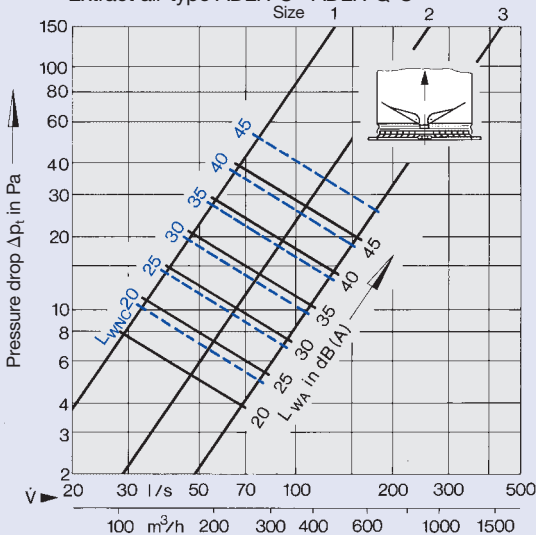

**Correction to diagram 7**

Flap damper		$\Delta p_t$	$L_{WA}$	$L_{WNC}$
100 %	Size 1 - 6	x 1	-	-
	Size 7	x 1.5	+ 5	+ 5
	Size 8	x 2.9	+ 9	+ 8
50 %	Size 1 - 7	x 1.7	+ 8	+ 7
25 %	Size 1 - 8	x 3.3	+ 17	+ 17

**Correction to diagram 8 and 9**

Flap damper		$\Delta p_t$	$L_{WA}$	$L_{WNC}$
100 %	Size 1 - 6	x 1	-	-
	Size 7	x 1.1	+ 1	+ 1
	Size 8	x 1.8	+ 6	+ 7
50 %	Size 1 - 7	x 1.1	+ 1	+ 1
25 %	Size 1 - 8	x 3	+ 8	+ 8

**9** Sound power level and pressure drop  
 Extract air type ADLR-C · ADLR-Q-C

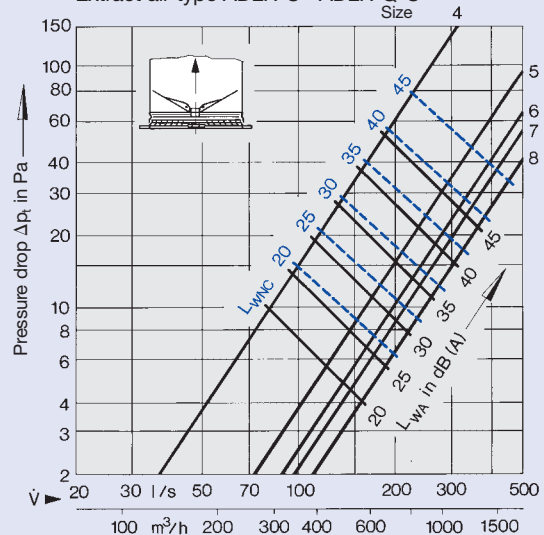

Diagram 10:

Temperature quotient

- Between the diffusers at 1.70 m height above the floor, with  $L = A/2 + H_1 = 2.0/2 + 1.30 = 2.30$  m the remaining supply air temperature differential is  $\Delta t_L = 0.08 \times (-8) = -0.64$  K

At 1.70 m height above the floor, at the distance to the wall  $L = X + H_1 = 1.5 + 1.3 = 2.80$  m the remaining temperature differential is  $\Delta t_L = 0.065 \times (-8) = -0.52$  K

At  $L = X + H_1 = 2.0 + 1.3 = 3.30$  m the remaining temperature differential is  $\Delta t_L = 0.05 \times (-8) = -0.4$  K

Diagram 12:

Air velocity

At  $A = 2.0$  m, the air velocity between the diffusers at 1.70 m height above the floor  $\bar{v}_{H1} = 0.16$  m/s.

At 1.70 m above the floor, at the distance to the wall  $L = X + H_1 = 1.5 + 1.3 = 2.80$  m the air velocity  $\bar{v}_L = 0.14$  m/s.

At the other distance to the wall  $L = X + H_1 = 2.0 + 1.3 = 3.30$  m the air velocity  $\bar{v}_L = 0.12$  m/s.

10 Temperature Quotient

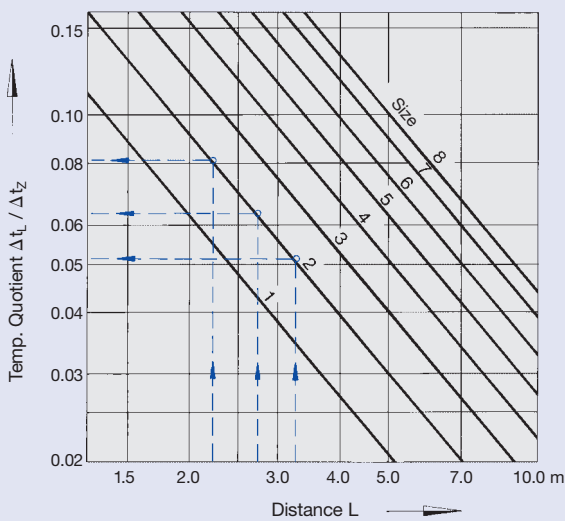

11 Air velocity Size 1

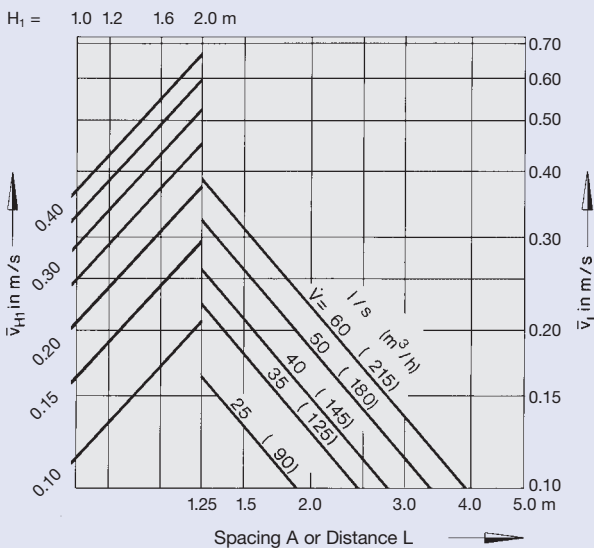

12 Air velocity Size 2

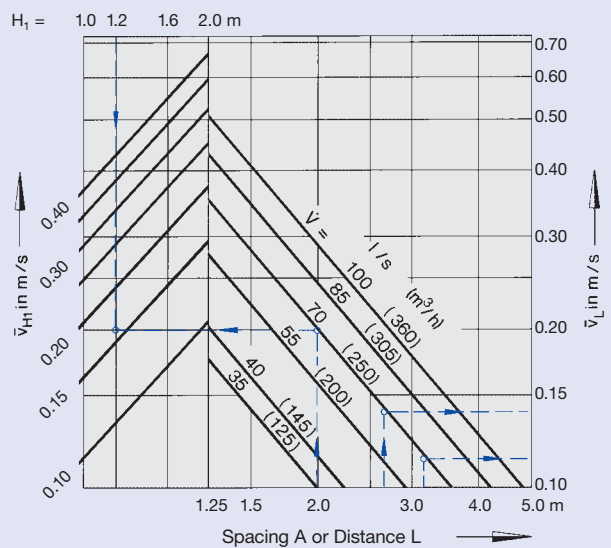

# Aerodynamic Data

Result:

On the basis of the calculations above, both the acoustic and air distribution requirements can be met, the use of 2 x ADLR-C size 2 installed as in diagram below is recommended.

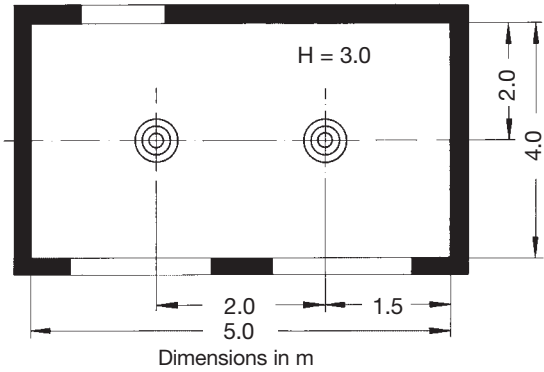

For a square arrangement of say 4 diffusers please multiply the air velocities from the diagrams by 1.4.

**13** Air velocity Size 3

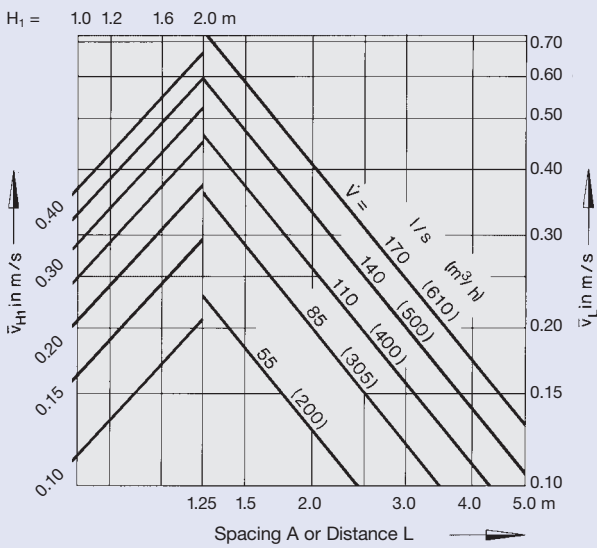

**14** Air velocity Size 4

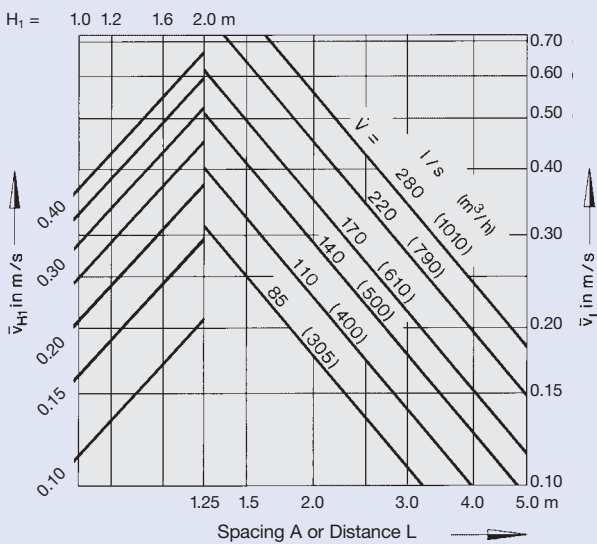

**15** Air velocity Size 5

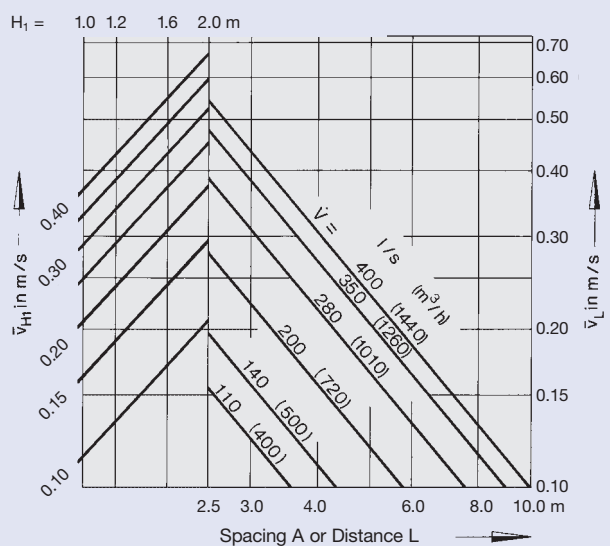

## 16 Air velocity Size 6

$H_1 = 1.0 \ 1.2 \ 1.6 \ 2.0 \text{ m}$

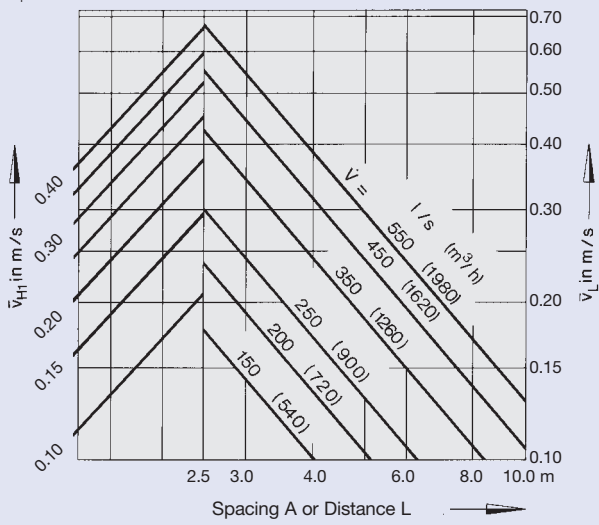

## 17 Air velocity Size 7

$H_1 = 1.0 \ 1.2 \ 1.6 \ 2.0 \text{ m}$

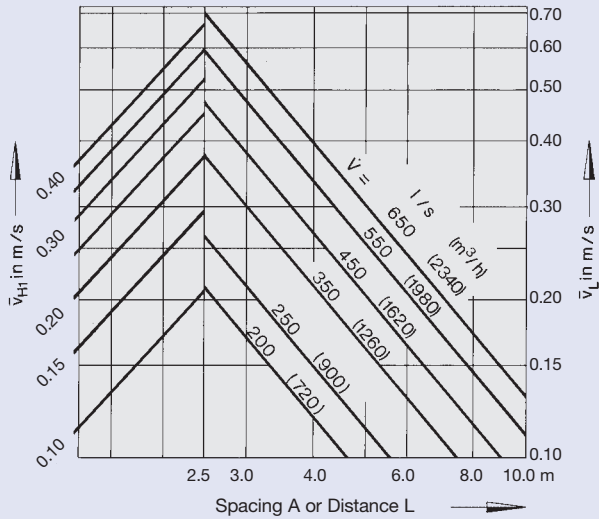

## 18 Air velocity Size 8

$H_1 = 1.0 \ 1.2 \ 1.6 \ 2.0 \text{ m}$

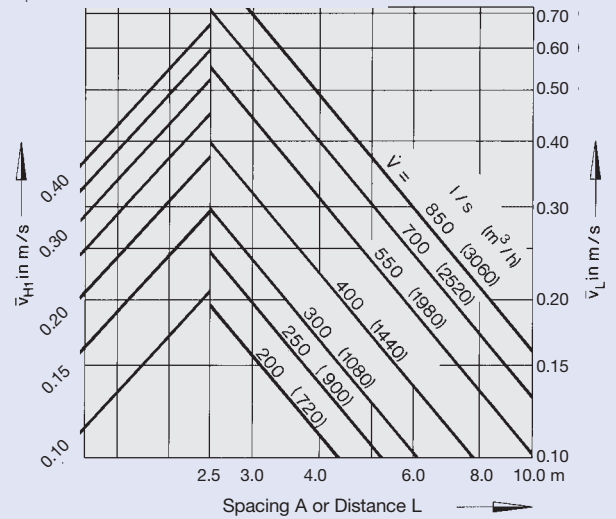

# Order Information

## Specification Text

Ceiling diffusers type ADLR (circular construction), type ADLR-Q (square construction) for flush installation in ceilings to provide a radial horizontal discharge for supply air application. The diffuser face comprises concentrically arranged circular rings and a circular or square border with peripheral sealing strip centre cone.

The diffuser face can be supplied with a rear connecting ring or flow rate control in the form of a butterfly damper adjustable from the diffuser face.

Plenum box with special internal air control elements and side or top entry circular spigots (alternatively, with spigot damper and/or lip seal and test point for measuring pressure). The plenum box also has holes for suspending the assembly from the ceiling slab.

The diffuser face is installed with a central screw and mounting subframe.

## Material

Aluminium diffuser face and formed sheet steel rear attachments. The surface of the diffuser face is pre-treated and powder-coated white RAL 9010 (gloss level GL = 50 %). The surfaces of the rear components are phosphate treated and stove enamelled black (RAL 9005) using an electro-dipping process, suitable for humid climates to DIN 50017 for at least 100 hours.

Plenum box of galvanised sheet metal, rubber lip seal.

## Order Code

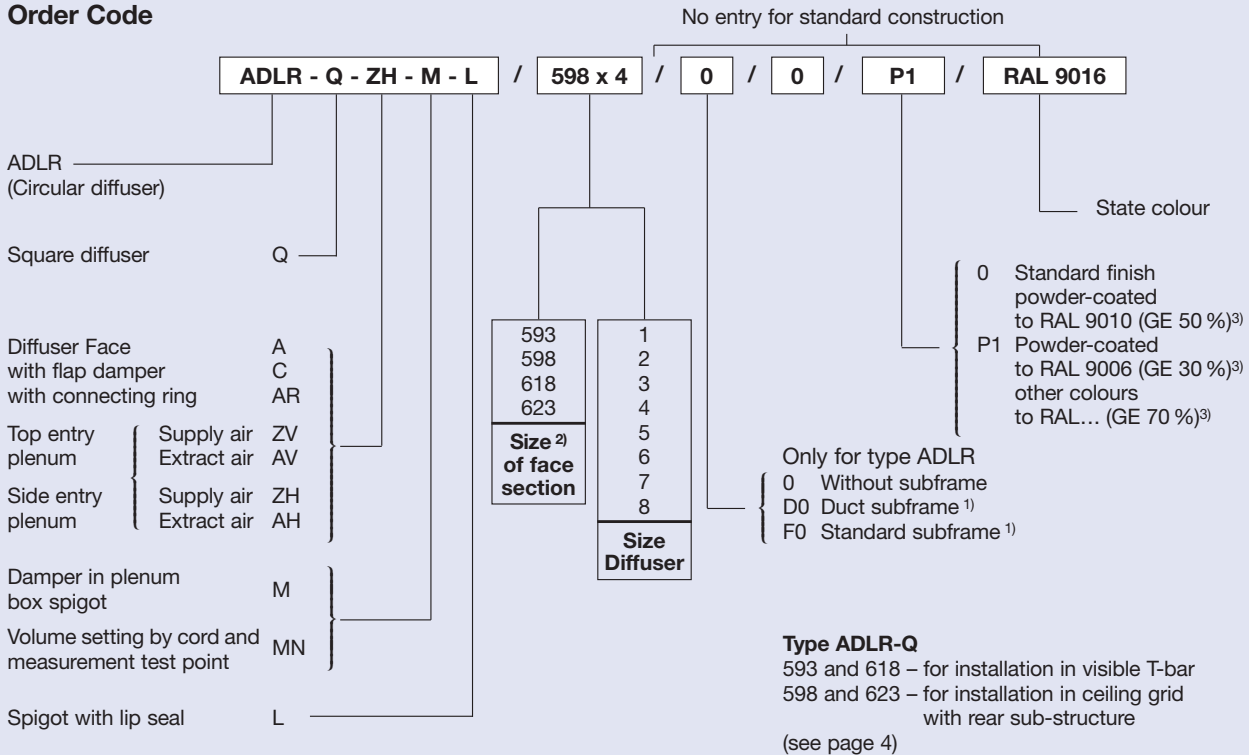

<sup>1)</sup> Only possible on constructions without plenum box

<sup>2)</sup> Only on variants with square face section Type ADLR -Q

<sup>3)</sup> GL = Gloss level

## Order Example · Type ADLR

Make: TROX  
 Type: ADLR - ZH - MN / 4 / 0 / 0 / P1 / RAL 9016

## Order Example · Type ADLR-Q

Make: TROX  
 Type: ADLR - Q - ZH - MN / 598 x 4 / 0 / 0 / P1 / RAL 9016