

VARYCONTROL VAV Controller

for variable volume systems
Type TVR



TROX[®] TECHNİK

The art of handling air

Contents · Description

Description _____	2	Quick selection · Sound pressure level _____	6
Construction · Dimensions _____	3	Air regenerated noise · Sound power level _____	7
Nomenclature · Dimensions · Weights _____	4	Case-radiated noise _____	8
Functional description _____	5	Order details _____	9

Type TVR VAV controller



Type TVRD VAV controller



TROX VARYCONTROL Types TVR and TVRD VAV controllers have been developed for the control of air flows, especially in variable volume flow systems.

- TVR: for supply air and extract air
- TVRD: for supply air and extract air with additional acoustic cladding

The mechanical components and electronic components which are factory fitted, form the controls package. Each unit is set up to the required flow rates and is subjected to an aerodynamic function test.

The controllers are fitted with an averaging differential pressure grid for measuring the air flow and a damper control blade.

The damper control blade with a plastic seal when closed complies with the air tightness requirements of DIN EN 1751. The entry and exit of the unit have circular spigots. For more stringent acoustic requirements, units with additional acoustic cladding and/or a circular silencer may be used.

The flow rate control is a closed loop system with external power supply. The pressure transmitter, controller and actuator are selected to meet the controls requirements and operational conditions. TROX VAV units can be supplied with control

components from any reputable manufacturer to suit the project specification. Further, current information on application, selection as well as control components available can be found in the “Technical Documentation” download area of our website. Also available on the Internet is the online design program “volume flow controller” for the design and selection of our units.

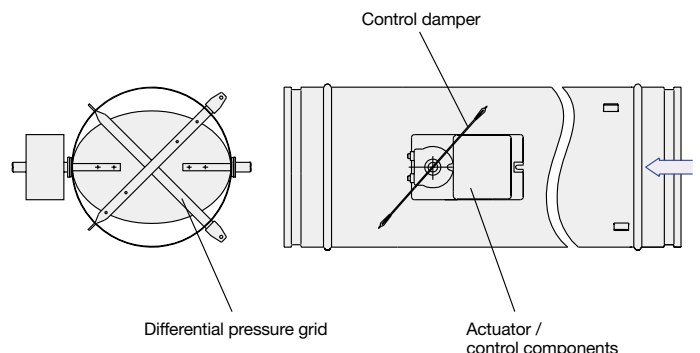

Characteristics

- Electronic volume flow control
- Suitable for supply or extract air
- Volume flow range (depending on manufacturer and type of controller) approx. 10:1
- High level of control accuracy for the volume flow settings, even at bends with $R = 1 D$.
Please ensure the most favourable aerodynamic configuration of ductwork is used.
- Differential pressure range 20 to 1500 Pa
- Full shut-off from ductwork system
- Control damper closed blade airtightness to DIN EN 1751, class 4 (nominal sizes 100 and 125, class 3)
- Horizontal or vertical installation (when using diaphragm pressure sensors, install according to label on the unit)
- Factory set up of volume flow or programming. This includes aerodynamic testing of each box using a dedicated test rig. Data covering set up is given on a test label attached to each unit
- Volume flow can be measured and subsequently reset on site; an additional peripheral device may be necessary for this
- Actual value signal referred to V_{nom}
- The controllers are, in terms of their mechanical parts, maintenance-free
- Operating temperature range 10 to 50 °C

Constructional features

- Circular spigot with groove for the use of a lip seal suitable for circular connecting ducts complying with DIN EN 1506 or DIN EN 13180 (if lip seals are required, these will be factory-fitted)
- Casing air leakage complies with DIN EN 1751, class A

Additional acoustic cladding

- Outer cover in galvanized sheet steel
- Sound-absorbent lining
- Structure-borne noise isolation
- Cannot be retro-fitted

Materials

- Casing and attachments in galvanized sheet steel
- Plastic plain bearings
- Control damper in galvanized sheet steel with thermoplastic elastomer seal
- Sensor tubes in aluminium

TVR, Basic construction

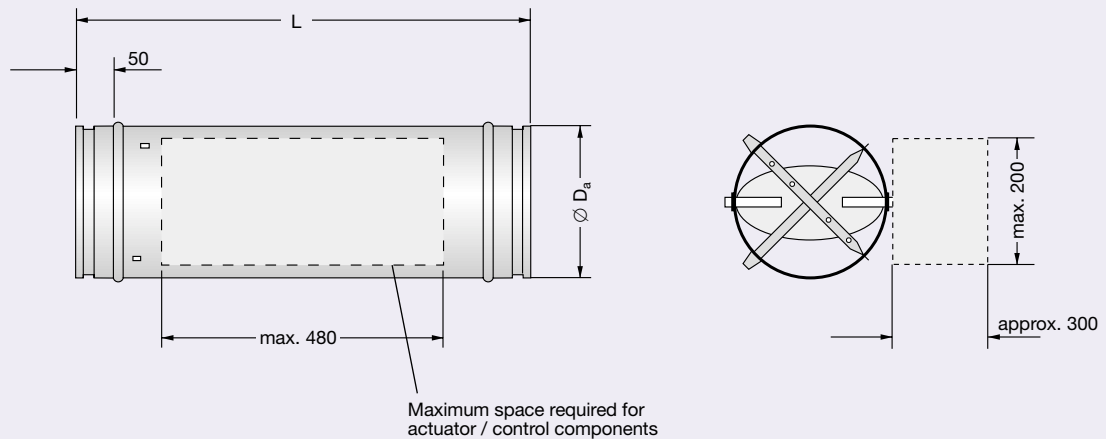

TVRD, Basic construction

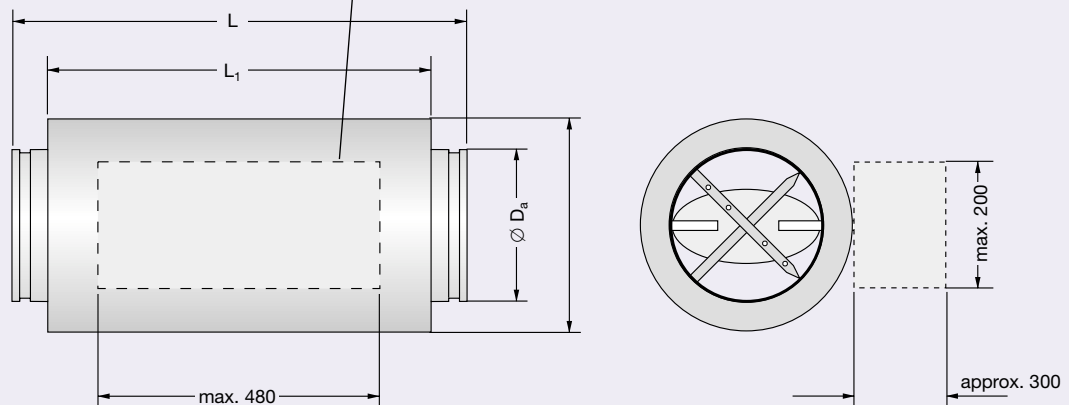

Nomenclature · Dimensions · Weights

Nomenclature

- f_m in Hz: Octave centre frequency
 L_{W} in dB: Sound power level of the air-regenerated noise in the room (low pressure) side ducting
 L_{W2} in dB: Sound power level of the case-radiated noise
 L_{W3} in dB: Sound power level of the case-radiated noise with additional acoustic cladding
 L_{pA} in dB(A): A-weighted sound pressure level of air-regenerated noise, system attenuation taken into account
 L_{pA1} in dB(A): A-weighted sound pressure level of air-regenerated noise with TS secondary silencer, system attenuation taken into account
 L_{pA2} in dB(A): A-weighted sound pressure level of case radiated noise
 L_{pA3} in dB(A): A-weighted sound pressure level of case radiated noise with additional acoustic cladding
 ΔL_W in dB: Correction value for case radiated noise sound power without additional acoustic cladding
 ΔL_{W1} in dB: Correction value for case radiated noise sound power with additional acoustic cladding
 Δp_g in Pa: Static pressure differential

- $\Delta p_{g \min}$ in Pa: Minimum static pressure differential
 ΔV in \pm %: Volume flow tolerance from set point
 \dot{V} in m^3/h or l/s: Volume flow
 \dot{V}_{nom} in m^3/h or l/s: Nominal volume flow (100 %)

All sound power levels are based on 1 pW, all sound pressure levels on 20 μPa .

All noise levels determined in a reverberation chamber. The sound power data was determined and corrected according to DIN EN ISO 5135, February 1999.

Flange details

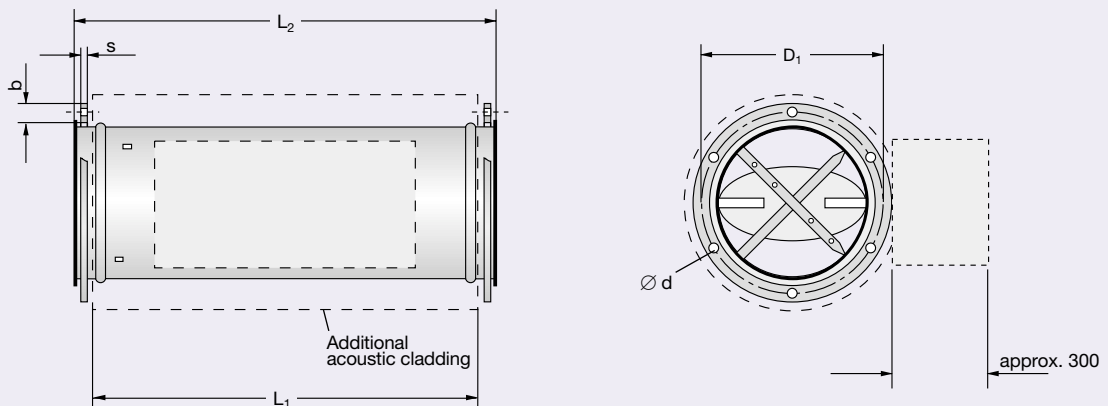

Dimensions in mm											Weights in kg					
Nominal size	$\varnothing D_a$	$\varnothing D_{a1}$	$\varnothing D_1$	b	s	$\varnothing d$	n ¹⁾	other control components			Compact controller			TVR	TVRD	Additional weight of flange
								L	L ₁	L ₂	L	L ₁	L ₂			
100	99	198	132	25	4	9.5	4	600	517	580	310	232	290	3.3	7.2	0.6
125	124	223	157	25	4	9.5	4	600	517	580	310	232	290	3.6	8.5	0.6
160	159	258	192	25	4	9.5	6	600	517	580	400	317	380	4.2	11.0	1.1
200	199	298	233	25	4	9.5	6	600	517	580	400	317	380	5.1	12.9	1.4
250	249	348	283	25	4	9.5	6	600	517	580	400	317	380	6.1	15.9	1.7
315	314	413	352	30	4	9.5	8	600	517	580	500	417	480	7.2	18.1	3.1
400	399	498	438	30	4	9.5	8	600	517	580	500	417	480	9.4	22.6	3.9

1) n = Number of holes in flange

Functional Description

Room temperature controller

In VAV systems, the room temperature control takes the form of a cascade control. The primary controlled variable is the room temperature. The output signal of the room temperature controller is not fed directly to the supply air control damper but alters the set value of the supply air volume flow control loop. The volume flow control also generates minimum and maximum limits for the air flow which has benefits in keeping the room temperature constant and for the functioning of the overall room air conditioning system.

Volumetric flow measurement

A sensor is necessary for the positive measurement of air flows, this is achieved by pressure measurement at several points distributed over the cross-section and provision of the resulting average value. The TROX differential pressure sensor is an optimum solution in terms of economics and product technology. This sensor delivers exact results for most room air conditioning applications based on normal flow entry conditions.

Volume flow control

The volume flow rate is controlled in a closed control loop, i.e. measurement – comparison – control.

A pressure transmitter converts the pressure difference into an electrical signal, which is interpreted as the actual value by the controller. In most applications, the set point comes from a room temperature controller.

The controller compares the actual value with the set point and alters the command signal to the damper actuator in the event of a difference between the two values.

Supply air/extract air tracking control

In single rooms and closed-off office areas, the balance between supply and extract air should be maintained. Otherwise annoying whistling noises occur at door gaps and the doors can be difficult to open. For that reason, the extract air should have variable control in a VAV system.

The actual value of the supply air is fed as a command signal to the extract air controller (tracking control). In this way, the extract air automatically follows the supply air, even when this has not reached its set value.

System diagram

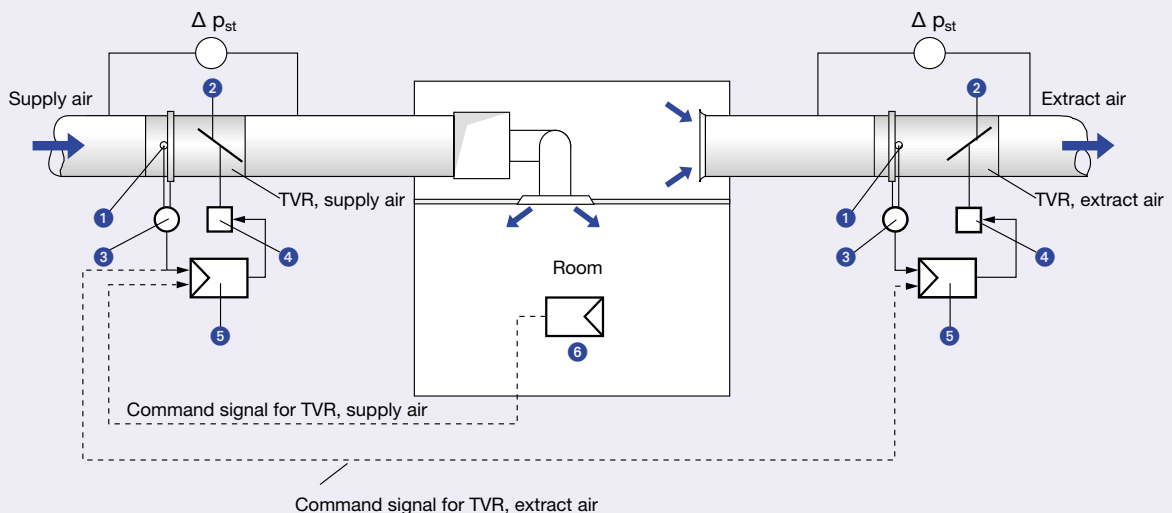

Legend

- ① Differential pressure sensor
- ② Control damper blade
- ③ Pressure transmitter
- ④ Actuator
- ⑤ Volume flow controller
- ⑥ Room temperature controller (supplied by others)
- Wiring by others

Control diagram

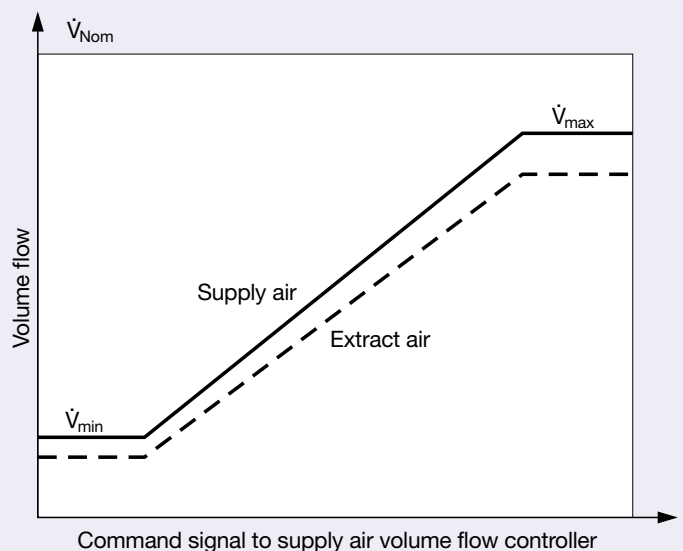

Quick Selection · Sound Pressure Level

System attenuation in dB/octave in accordance with VDI 2081 (taken into account in the quick selection table)

f_m in Hz	63	125	250	500	1000	2000	4000	8000
Duct bend attenuation	0	0	1	2	3	3	3	3
Room attenuation	5	5	5	5	5	5	5	5
End reflection	10	5	2	0	0	0	0	0

Correction for distribution into the low pressure duct (taken into account in the quick selection table)

\dot{V} in m ³ /h	500	1000	1500	2000	2500	3000	4000	5000	6000
l/s	139	278	417	556	695	834	1111	1389	1667
dB per octave	0	3	5	6	7	8	9	10	11

Correction for other pressure differentials (averaged values)

Δp_g in Pa	100	200	400	600	800	1000
dB	-5	0	6	9	11	14

Quick selection of sound pressure level in dB(A) at $\Delta p_g = 200$ Pa

Nominal size	\dot{V}		$\Delta p_{g \min}$	$\Delta \dot{V}$	L_{pA}	Air regenerated noise			Case radiated noise ¹⁾	
						L_{pA1}			L_{pA2}	L_{pA3}
	l/s	m ³ /h	Pa	± %	without silencer	with CS/CF type silencer length in mm			without additional acoustic cladding	with additional acoustic cladding
100	10	36	20	15	35	22	12	10	15	6
	39	140	20	8	47	37	29	27	26	19
	65	234	35	7	54	45	37	35	33	26
	95	342	70	5	57	47	38	35	37	29
125	15	54	20	15	37	24	14	10	17	7
	61	220	20	7	48	39	33	30	27	19
	107	385	55	6	52	44	38	36	32	24
	150	540	90	5	55	45	38	35	36	26
160	25	90	20	15	42	30	20	16	21	11
	100	360	25	8	51	42	37	34	30	21
	175	630	40	7	54	46	41	38	34	25
	250	900	70	5	56	48	42	40	38	29
200	40	144	20	15	44	34	25	22	23	8
	161	580	20	7	50	43	37	36	30	17
	282	1015	35	5	53	47	43	42	34	23
	405	1458	65	5	56	48	43	42	39	27
250	60	216	20	15	41	32	25	23	23	10
	247	888	20	7	49	43	37	35	35	19
	432	1554	25	5	50	44	40	39	38	25
	615	2214	45	5	54	46	41	40	42	30
315	105	378	20	15	47	39	32	28	31	13
	411	1480	20	7	50	45	39	37	40	22
	719	2590	20	6	52	47	41	40	43	29
	1025	3690	30	5	55	50	44	43	47	35
400	170	612	20	15	48	41	34	30	33	14
	671	2414	20	7	49	43	37	35	40	23
	1173	4225	25	6	49	44	39	37	42	30
	1680	6048	25	5	52	47	41	40	47	35

1) 4 dB/octave false ceiling sound reduction and 5 dB/octave room attenuation were taken into consideration in the calculation of radiated noise. For acoustic data for differential pressure > 500 Pa, see on-line design program "volume flow controller".

Air Regenerated Noise · Sound Power Level

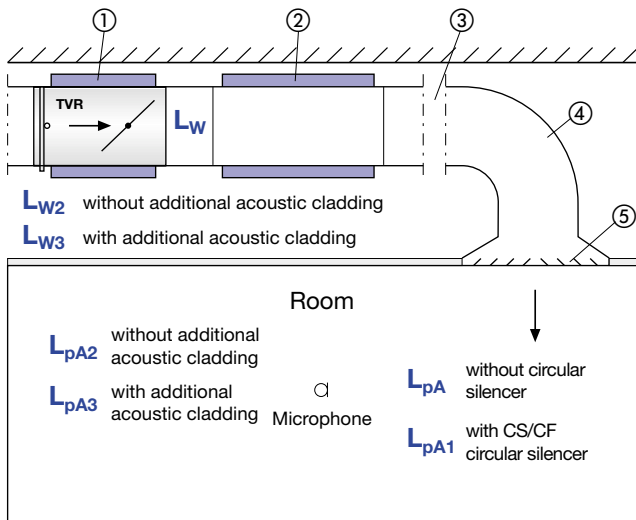

- ① Additional acoustic cladding
- ② CS/CF circular silencer
- ③ Air distributed between several diffusers
- ④ Duct bend attenuation
- ⑤ End reflection at the diffuser

Nomenclature, see page 4

Sound power level air regenerated noise

Nominal size	\dot{V}		$\Delta p_g = 100 \text{ Pa}$								$\Delta p_g = 200 \text{ Pa}$								$\Delta p_g = 500 \text{ Pa}$							
			L_w in dB								L_w in dB								L_w in dB							
			f_m in Hz								f_m in Hz								f_m in Hz							
			63	125	250	500	1000	2000	4000	8000	63	125	250	500	1000	2000	4000	8000	63	125	250	500	1000	2000	4000	8000
l/s	m ³ /h																									
100	10	36	55	41	40	37	28	17	6	5	55	45	44	42	37	29	20	16	54	48	50	49	45	44	43	35
	39	140	65	62	54	47	40	34	30	24	66	64	59	52	47	41	36	32	68	66	66	60	56	53	48	45
	65	234	66	66	61	52	47	44	38	32	70	71	68	58	51	47	43	40	73	75	76	66	61	57	52	51
	95	342	62	61	62	57	52	50	43	37	71	71	71	61	56	53	48	43	77	79	80	70	63	59	55	54
125	15	54	43	40	40	39	31	20	10	5	50	42	44	44	40	33	23	18	58	48	48	49	47	47	45	37
	61	220	61	60	53	47	41	36	30	23	64	65	59	53	47	42	38	33	68	68	67	63	58	56	51	48
	107	385	62	63	57	50	50	44	39	30	69	70	63	56	53	47	46	39	72	76	74	66	61	57	54	52
	150	540	64	58	58	54	54	48	43	38	70	68	66	59	57	52	50	45	76	79	79	68	63	59	58	56
160	25	90	46	44	45	45	39	34	22	16	48	46	46	48	45	40	30	24	55	55	52	54	54	52	49	42
	100	360	63	61	55	48	45	43	34	28	67	66	61	55	51	50	43	37	70	71	69	64	62	63	56	52
	175	630	65	64	58	52	51	47	40	34	71	71	65	58	55	53	48	43	77	78	75	68	64	64	59	56
	250	900	65	65	62	57	57	51	46	40	74	73	69	62	60	57	52	47	82	82	79	71	66	66	61	59
200	40	144	54	47	45	44	38	34	33	24	50	50	47	49	46	43	42	30	54	51	52	54	56	54	54	44
	161	580	64	62	52	48	48	47	43	33	68	67	58	53	50	50	50	42	73	71	67	63	59	60	63	55
	282	1015	66	71	59	55	54	49	44	35	73	75	63	58	56	54	53	45	79	81	72	66	62	63	65	59
	405	1458	72	70	62	62	60	55	51	45	77	77	68	64	62	59	56	50	83	85	77	70	66	66	67	62
250	60	216	49	46	41	40	34	27	18	11	49	50	46	48	44	40	32	28	49	54	53	57	58	56	53	45
	247	888	61	60	51	49	47	51	47	40	65	65	56	53	49	50	52	47	70	71	65	61	57	56	55	58
	432	1554	65	70	59	56	52	49	44	39	70	73	62	59	54	53	53	47	78	79	71	66	61	60	60	60
	615	2214	71	68	62	64	59	56	50	45	75	74	68	66	60	58	56	50	82	82	76	71	64	64	63	63
315	105	378	48	47	44	42	41	40	27	21	52	51	48	50	49	50	39	32	54	53	53	55	61	63	56	48
	411	1480	64	61	54	51	48	53	50	44	68	66	59	55	52	56	55	48	75	73	67	63	61	66	60	61
	719	2590	71	70	62	58	54	54	52	46	75	74	66	62	57	58	58	53	81	80	74	68	64	68	63	65
	1025	3690	75	72	71	65	60	58	53	47	79	76	74	68	62	62	59	55	86	84	80	74	67	70	66	66
400	170	612	46	46	46	44	44	41	25	18	52	50	49	50	52	51	38	31	56	53	54	57	63	67	57	54
	671	2414	64	61	54	51	51	47	39	33	70	66	59	56	56	57	52	46	74	71	66	63	64	69	63	65
	1173	4225	70	69	64	62	54	51	45	40	74	72	66	63	58	58	52	48	81	79	72	68	67	71	65	63
	1680	6048	78	69	66	67	60	57	52	51	79	74	72	69	63	62	56	56	85	81	77	73	69	73	66	63

Case-radiated Noise

Example

Given: $\dot{V}_{\max} = 360 \text{ m}^3/\text{h}$
 $\Delta p_{\text{st}} = 500 \text{ Pa}$
 Required sound pressure level in the room 35 dB(A)
 For further assumptions, see calculation procedure

Calculation procedure

Quick selection:
 TVR 160
 $L_{pA2} = 38 \text{ dB(A)}$
 $L_{pA3} = 29 \text{ dB(A)}$

Calculation procedure case radiated noise

f_m	63	125	250	500	1000	2000	4000	8000
L_W (Page 7)	70	71	69	64	62	63	56	52
ΔL_W	30	29	24	21	19	16	14	12
L_{W2}	40	42	45	43	43	47	42	40
Ceiling reduction	4	4	4	4	4	4	4	4
Room attenuation	6	6	5	5	4	4	4	4
A-weighting	-26	-16	-9	-3	0	1	1	-1
Corrected level	4	16	27	31	35	40	35	31

Result: L_{pA2} **approx. 43 dB(A)**, acoustic cladding required.

Calculation with ΔL_{W1} result is **approx. 31 dB(A)**, the requirement is met.

Correction values for case-radiated noise in dB

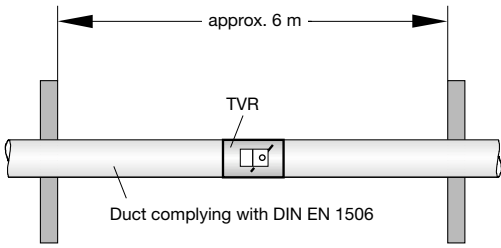
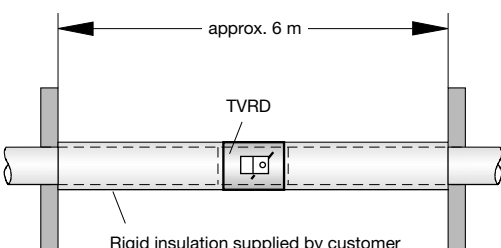
Installation location	$\Delta L_W / \Delta L_{W1}$	Nominal size	$\Delta L_W / \Delta L_{W1}$ in dB, related to f_m in Hz							
			63	125	250	500	1000	2000	4000	8000
TVR $L_{W2} = L_W - \Delta L_W$ 	ΔL_W	100	31	30	27	21	19	11	11	9
		125	30	29	25	21	18	12	12	10
		160	30	29	24	21	19	16	14	12
		200	29	28	23	22	21	18	16	13
		250	25	24	20	18	16	14	12	11
		315	22	22	19	17	15	13	11	10
		400	20	19	18	17	15	12	10	10
TVRD $L_{W3} = L_W - \Delta L_{W1}$ 	ΔL_{W1}	100	33	28	26	26	34	33	37	31
		125	32	29	24	27	33	33	37	32
		160	32	32	24	28	34	38	40	34
		200	31	31	26	33	39	44	43	35
		250	27	27	23	29	35	42	36	31
		315	24	25	23	29	34	41	35	29
		400	22	23	22	29	35	39	33	29

Specification text *

Circular VAV controller for variable air volume flow systems, for supply air or extract air, in 7 sizes. Consists of a casing with damper control blade, differential pressure sensor, and control components.

The closed damper control blade airtightness according to DIN EN 1751, class 4, but for nominal sizes 100 and 125 class 3. The position of the damper control blade is visible from outside on the shaft extension.

Special features:

- Averaging differential pressure sensor with 3 mm measuring holes and so not sensitive to contamination
- Factory set up of volume flow or programming. This includes aerodynamic testing of each controller using a dedicated test rig. Data covering the set up is given on a label attached to the controller.
- Actual value signal related to \dot{V}_{Nom} , and so easier commissioning or retrospective volume flow setting

Spigots suitable for ducts complying with DIN EN 1506 or DIN EN 13180, with groove for lip seal. Casing air leakage complies with DIN EN 1751, class A.

Differential pressure range 20 to 1500 Pa, volume flow range depends on the manufacturer of the controller, approx. 10 : 1.

Control:

- Variable volume flow control, electronic controller for the connection of the command signal, actual value signal related to \dot{V}_{Nom} may be read.
- Supply voltage 24 VAC
- Signal voltages from 0 to 10 VDC
- Dynamic differential pressure measurement

Materials:

Casing made of galvanized sheet steel, damper control blade with thermoplastic elastomer seal, sensor grid tubes made of aluminium, plastic plain bearings.

Options:

Additional acoustic cladding for the reduction of case-radiated noise with structure-borne noise isolation, sound reduction of minimum 7 dB, consists of 40 mm mineral wool and outer cover consisting of 1 mm galvanized sheet steel, non-retrofitable.

* The basic construction is described here; for variants, see the online selection program or price list

Order code

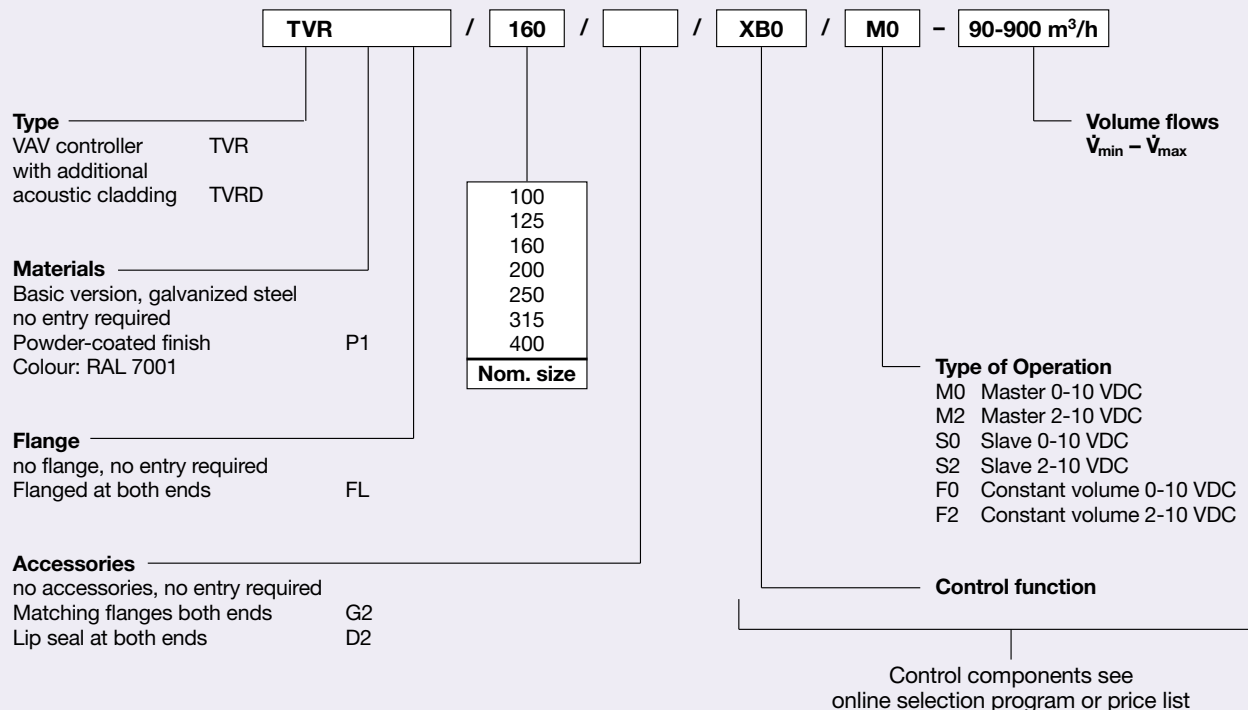

Order example

Make: TROX
 Type: TVR / 160 / XB0 / M0 - 90-900 m³/h

