

### 1. Applications

The smoke detector RM-O-VS-D-LON is used for control of

- Fire dampers with electric or electro-pneumatic release mechanisms (power off to operate/close principle) and
- Smoke dampers with electric spring return actuators

which are equipped with LON-Modules as the Trox LON-WA1/B. Due to the LonWorks<sup>®</sup> Technology the smoke detector can be connected to several dampers without any increased effort for wiring and let the dampers close in case of fire. Thereby the transfer of smoke by the ventilation ducting of the room air conditioning systems (RLT-systems) shall be prevented.

The LON-interface enables the integration of the smoke detectors into primary systems (BMS), so the smoke detectors can be simply operated and monitored from a central location.

The external inspection of the basic device, as stipulated by law, is carried out by VdS Schadenverhütung GmbH, Cologne.

- ① Smoke detector with mains adapter, sensor electronics, smoke sensor and air flow monitor unit
- ② "Reset / Test" button
- ③ Signal lamp - green - "System monitoring"
- ④ Signal lamp - red - "Alarm condition"
- ⑤ Signal lamp - yellow - "Contamination indicator"
- ⑥ Signal lamp - blue - "Air flow monitoring"



### 2. Technical Data

**Supply voltage:**

230 VAC, 50/60 Hz

**Power consumption:**

max. 6 VA

**Protection class:**

IP 42

**Ambient temperature range:**

0°C to + 60°C

**Permissible air velocity range:**

1 m/s to 20 m/s

**Permissible humidity range:**

0 to 90 % relative humidity (condensation and induction of steam can lead to false alarms)

**Warning limit for increased contamination:**

> 70 %

**Warning limit for airflow:**

< 2 m/s

**System monitoring:**

Smoke sensor head missing  
Data transmission smoke sensor head defective

**EMC:**

Interference protection to EN 50081-1 and EN 50130-4

**Weight:**

approx. 1.5 kg

**Software-application:**

The available applications (XIF/APB-file) for the RM-O-VS-D-LON can be downloaded from the Internet under [www.trox.de](http://www.trox.de)

### 3. Functional description

The device consists of the basic device RM-O-VS-D with German test certificate (general building approval) Z-78.6-67, as well as integrated signal lamps, a smoke-sensor and flow monitor unit.

The smoke sensor head of the smoke detector is equipped with an intelligent bus-controlled sensor, which is operating by using the optical light scatter principle. It is possible to inquire multiple parameters by LON, e.g. contamination grade or general condition of the sensor. Also the smoke detector can be switched into a test-mode from a central location to inspect the functionality of the smoke detector and fire-/smoke damper.

Additionally an air flow monitor is built in, which is monitoring the airflow. If the air velocity is below 2 m/s, a warning is send by LON and the signal lamp of the device extinguishes. But the smoke detection in the ventilation ducting is also functioning at velocities below 2 m/s, as the sensor can detect smoke also on low velocities. The airflow control can be inquired by a LON-network-variable and directly checked on the device on site by a signal lamp.

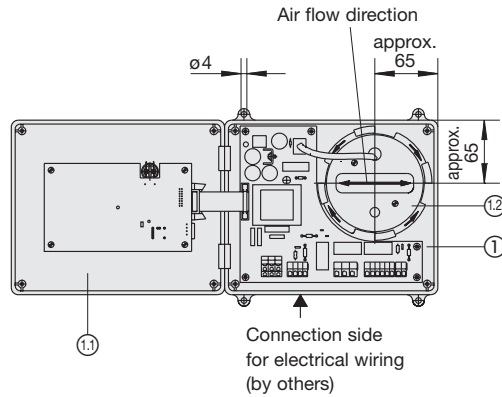

#### Casing RM-O-VS-D-LON:

- ① Smoke detector with mains adapter, sensor electronics, smoke sensor and air flow monitor unit
- ①.1 Sealed cover connected to casing with hinges
- ①.2 Smoke sensor / air flow monitoring unit

#### Dimensions

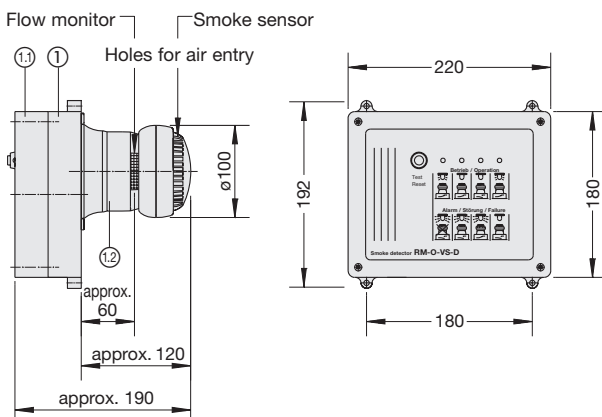

#### The following should be noted

- If a set response threshold for the smoke is exceeded, the smoke detector signals a smoke alarm. The related fire or smoke damper closes. Fresh air or recirculation fans must be shut down if their continued operation will result in the further spread of smoke.
- “Regulations on fire protection requirements for ventilation plants” all applicable National Codes must be observed.
- The smoke detector may not be used to send an alarm to the fire service.
- Before commissioning the ventilation plant, the sensor heads must be protected against contamination by dirt (dirt particles can result in false alarms).
- “General and special provisions” of the National Building Codes must be observed.
- Installation and maintenance instructions can be found in the leaflet enclosed with the delivery.

### 3.1 Functional overview RM-O-VS-D-LON

In the illustrated overview below the functions of the existing signal lamps (LED) on the device are shown.

Depending on the operating-mode also the respective status (open/closed) of the connected fire-/smoke damper is shown.

| Fire or smoke damper | Operational status / Event   |        | Signal    | Alarm relay           | LED lamp                 | Signal relay              | LED lamp                              |
|----------------------|--|--------|-----------|-----------------------|--------------------------|---------------------------|---------------------------------------|
|                      | OPEN   | CLOSED |           | LED lamp - red -      | - yellow - Contamination | LED lamp - green - System | LED lamp - blue - Air flow > 2 m/s 2) |
|                      |  |        |           | Terminal block - L3 - |                          | Terminal block - L4 -     |                                       |
|                      | Mains turned on<br><b>- Functional status -</b>  |        | LED       |                       |                          |                           |                                       |
|                      |  |        | Contact   |                       |                          |                           |                                       |
|                      | Mains not turned on  |        | LED       |                       |                          |                           |                                       |
|                      |  |        | Contact   |                       |                          |                           |                                       |
|                      | Mains turned on<br>• Electronics defective,<br>• No/defective smoke sensor<br><b>- Alarm situation, immediate release signal -</b> |        | 3) LED    |                       |                          |                           |                                       |
|                      |  |        | Contact   |                       |                          |                           |                                       |
|                      | Dust / Contamination > 70 %<br>< 90 %  |        | 1) LED    |                       |                          |                           |                                       |
|                      |  |        | Contact   |                       |                          |                           |                                       |
|                      | Test / Reset<br><b>- Inspection -</b>  |        | LED       |                       |                          |                           |                                       |
|                      |  |        | Contact   |                       |                          |                           |                                       |
|                      | Contamination > 90 %<br><b>- Alarm situation, immediate release signal -</b>   |        | 1) 3) LED |                       |                          |                           |                                       |
|                      |  |        | Contact   |                       |                          |                           |                                       |
|                      | Smoke<br><b>- Alarm situation, immediate release signal -</b>  |        | LED       |                       |                          |                           |                                       |
|                      |  |        | Contact   |                       |                          |                           |                                       |
|                      | Manual release can only be cancelled using "Reset"   |        | LED       |                       |                          |                           |                                       |
|                      |  |        | Contact   |                       |                          |                           |                                       |

- 1) Contamination indicator  
 up to 70 % - Normal range  
 > 70 % - 90 % - Warning range  
 > 90 % - Alarm range
- 2) The blue LED goes out at air velocity < 2 m/s or after the fire or smoke damper closes.

- 3) The alarm situation, triggered by smoke (event or maintenance), can only be cancelled by pressing the button after the smoke sensor head is again free of smoke.

LED lit    LED flashing    LED off!

### 4. Description Function object

The LON node consists of the node object and the functional block RM-O-VS-D. The functional block consists of network variables and configuration parameters. All variables and parameters are based on standard network variables (SNVT), whereby a simple integration of the smoke detector in a LonWorks network is guaranteed. The specification is oriented as far as possible by the LonMark-Profile 11003 "Smoke (Conventional) Fire Initiator" and has been extended for the special functions of the RM-O-VS-D-LON.

#### 4.1 Network Variables

##### Node Object:

The node object provides mechanisms, which allow to analyse and influence the node as a whole. It administrates all other objects of the node and appears only once in a node. It contains no applications, but only pays attention to the node. Tasks of the node-object are e.g. network management functions and status reports.

##### nviRequest

SNVT Type: SNVT\_obj\_request

Function:

Request of diverse information and execution of actions in the node.

The following parameters can be received:

- RQ\_Normal: Initialise the node, reset status
- RQ\_Disabled: Not activated
- RQ\_Update\_Status: Inquiry of status, reply via NvoStatus
- RQ\_Update\_Alarm: Not activated
- RQ\_Report\_Mask: Mask of all possible status bits
- RQ\_Enable: Not activated
- RQ\_Clear\_Alarm: Not activated
- RQ\_Self\_Test: Self-test of node

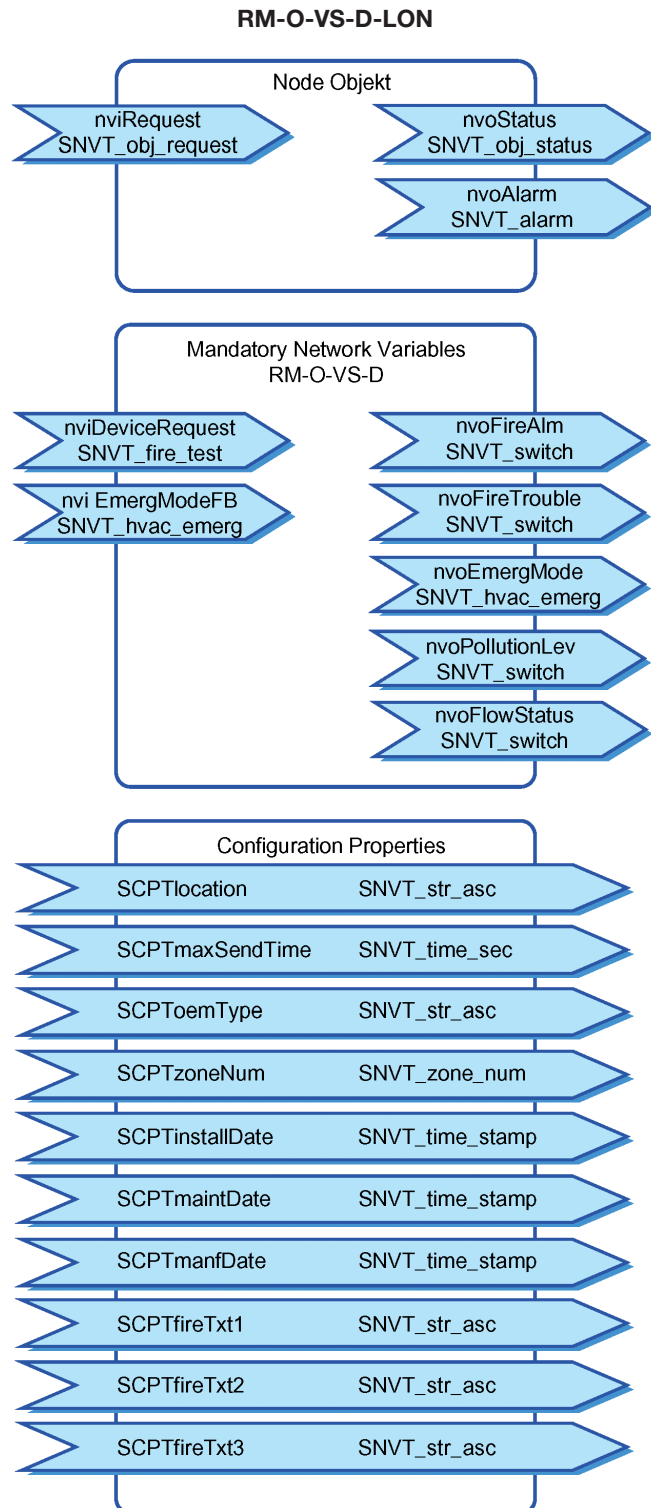

### nvoStatus

SNVT Type: SNVT\_obj\_status

Function:

Output variable receives the reply on a previously by nviRequest queried request with the demanded status bits:

invalid\_id: incorrect Object-Id requested respectively non-existent

invalid\_request: incorrect parameter requested respectively non-existent

disabled: node without function (not activated)

comm\_failure: communication disturbed

fail\_self\_test: test run faulty

self\_test\_in\_progress: test run faulty

### nvoAlarm

SNVT Type: SNVT\_alarm

Function:

This function is not implemented.

### Mandatory Network Variables:

#### nviDeviceRequest

SNVT Type: SNVT\_fire\_test

Function:

By this input the smoke detector can be switched into test-mode or a reset can be activated. The detailed functions are shown in the table.

| Value | Request   | Function              |
|-------|-----------|-----------------------|
| 0     | FT_NORMAL | Object in normal-mode |
| 1     | FT_RESET  | Reset smoke sensor    |
| 2     | FT_TEST   | Test smoke sensor     |
| 3     | FT_NOTEST | Abort test            |
| 0xFF  |           | No value              |

After an executed test, the test either has to be aborted or a reset has to be executed to return to normal-mode.

### nviEmergModeFb

SNVT Type: SNVT\_hvac\_emerg

Function:

This output transmits the following functions:

Valid values:

EMERG\_NORMAL: 90° position  
EMERG\_FIRE: 0° position

Standard value: EMERG\_NUL

This input serves to feed back an actuator signal. It is only effective, if in fact a connection (binding) to the actuator exists. If this exists, in case of the signal EMERG\_FIRE automatically the output nvoEmergMode and nvoFireAlm are set independent of the condition of the sensor.

### nvoFireAlm

SNVT Type: SNVT\_switch

Function:

This output signalises the fire alarm.

Valid values:

| Value | State | Function |
|-------|-------|----------|
| 0,0   | 0     | no Alarm |
| 100,0 | 1     | Alarm    |

Default setting: 0

The status of the output is either transmitted spontaneously upon a change in status or cyclically with the value set in the parameter nciMaxSendTime.

### nvoFireTrouble

SNVT Type: SNVT\_switch

Function:

By this output the function standby of the smoke detector is displayed. Also defects on the electronics are transmitted by this variable.

Valid values:

| Value | State | Function      |
|-------|-------|---------------|
| 0,0   | 0     | no Alarm      |
| 100,0 | 1     | Sensor defect |

The values are transmitted spontaneously upon any change occurring.

### nvoEmergMode

SNVT Type: SNVT\_hvac\_emerg

Function:

This output serves to control fire-respectively smoke-dampers. In case of fire the message is transmitted via LON as well as via a relay contact.

This LON-output transmits the following functions:

Valid values:

EMERG\_NORMAL: 90° position

EMERG\_FIRE: 0° position

Default setting: EMERG\_NORMAL

The status of the output is either transmitted spontaneously upon a change in status or cyclically with the value set in the parameter nciMaxSendTime.

### nvoPollutionLev

SNVT Type: SNVT\_switch

Function:

This output transmits the actual degree of pollution of the smoke detector in percent. On a contamination grade above 90 % the output nvoEmergMode is set to the function Emerg\_fire.

Valid values:

| Value | State | Function                       |
|-------|-------|--------------------------------|
| 0,0   | 0     | Contamination grade            |
| 100,0 | 1     | Sensor contaminated, servicing |

The changes of the degree of pollution are transmitted spontaneously upon any change occurring.

### nvoFlowStatus

SNVT Type: SNVT\_switch

Function:

By this output the status of the actual air velocity is transmitted. The warning limit is at 2 m/s.

Valid values:

| Value | State | Function             |
|-------|-------|----------------------|
| 0,0   | 0     | Air velocity o.k.    |
| 100,0 | 1     | Air velocity < 2 m/s |

The values are transmitted spontaneously upon any change occurring.

### 4.2 Configuration parameters

In the following, the available configuration parameters are described:

#### SCPTlocation

SCPT Type: SCPTlocation

SCPT-Reference: 17

Function:

Description of the physical location of the node by up to 30 ASCII – characters.

No standard-value is defined.

Valid range:

Defined in the accordant SNVT\_str\_asc.

#### SCPTmaxSendTime

SCPT Type: SCPTmaxSendTime

SCPT-Reference: 49

Function:

By this configuration parameter the cyclical transmission of the output-variable values nvoEmergMode and nvoFireAlm is defined.

The default setting is 0.0 seconds and deactivates the function. The values are then transmitted spontaneously upon any change occurring.

Valid range:

Defined in the accordant SNVT\_time\_sec.

#### SCPToemType

SCPT Type: SCPToemType

SCPT-Reference: 61

Function:

Here the type identification of the device is registered and is changeable by the operator.

The default setting is “TroX RM-O-VS-D”.

Valid range:

Defined in the accordant SNVT\_str\_asc.

#### SCPTzone Num

SCPT Type: SCPTzoneNum

SCPT-Reference: 141

Function:

Here it is possible for the user to enter a zone number, which gives a conclusion about the location of the node.

No standard-value is defined.

Valid range:

0. 65,534

**SCPTinstallDate**SCPT Type: SCPTinstallDate  
SCPT-Reference: 146Function:  
Date and time of installation of the node in the LON-network.

The default setting is 0/0/0 0:0:0.

Valid range:  
Defined in the accordant SNVT\_time\_stamp.**SCPTmaintDate**SCPT Type: SCPTmaintDate  
SCPT-Reference: 147Function:  
Date and time of the last maintenance or inspection of the smoke detector.

The default setting is 0/0/0 0:0:0.

Valid range:  
Defined in the accordant SNVT\_time\_stamp.**SCPTmainfDate**SCPT Type: SCPTmainfDate  
SCPT-Reference: 148Function:  
Date and time of fabrication of the device.  
The configuration parameter cannot be changed by the user and serves solely as information.Valid range:  
Defined in the accordant SNVT\_time\_stamp.**SCPTfireTxt1**SCPT Type: SCPTfireTxt1  
SCPT-Reference: 149Function:  
Here a text can be left that may be retrieved during a detected fire. The definition of this text occurs during the installation or the configuration of the node. The character ">" at the end of the text signalises, that the text is continued in the variable nciFireText2.Valid range:  
Defined in the accordant SNVT\_str\_asc.**SCPTfireTxt2**SCPT Type: SCPTfireTxt2  
SCPT-Reference: 150Function:  
Here a text can be left that may be retrieved during a detected fire. The definition of this text occurs during the installation or the configuration of the node. The character ">" at the end of the text signalises, that the text is continued in the variable nciFireText3.Valid range:  
Defined in the accordant SNVT\_str\_asc.**SCPTfireTxt3**SCPT Type: SCPTfireTxt3  
SCPT-Reference: 151Function:  
Here a text can be left that may be retrieved during a detected fire. The definition of this text occurs during the installation or the configuration of the node.Valid range:  
Defined in the accordant SNVT\_str\_asc.

## 5. Connection diagram

The smoke detector RM-O-VS-D-LON is to be wired by the connection diagram shown below.

Through the LON connection terminals the smoke detector is integrated into the LonWorks network and can exchange the necessary information with the LON-modules e.g. LON-WA1 /B, the fire- or smoke-dampers, as well as to primary systems.

The smoke detector can on demand supply the signals for the release mechanism, airflow monitoring and can supply the degree of pollution also by the relay contacts.

Further fundamental descriptions about this as well as for the installation and maintenance can be found in the product leaflet 4/6.2/EN/1 "smoke detector type RM-O-VS-D" respectively the German test certificate (general building approval) Z-78.6-67.

The entire electrical system must be installed in accordance with VDE (or National equivalent) and the local Energy Supply Company regulations.

Also current National Legal Standards related to the "Regulations on fire protection requirements for ventilation plants" must be complied with.

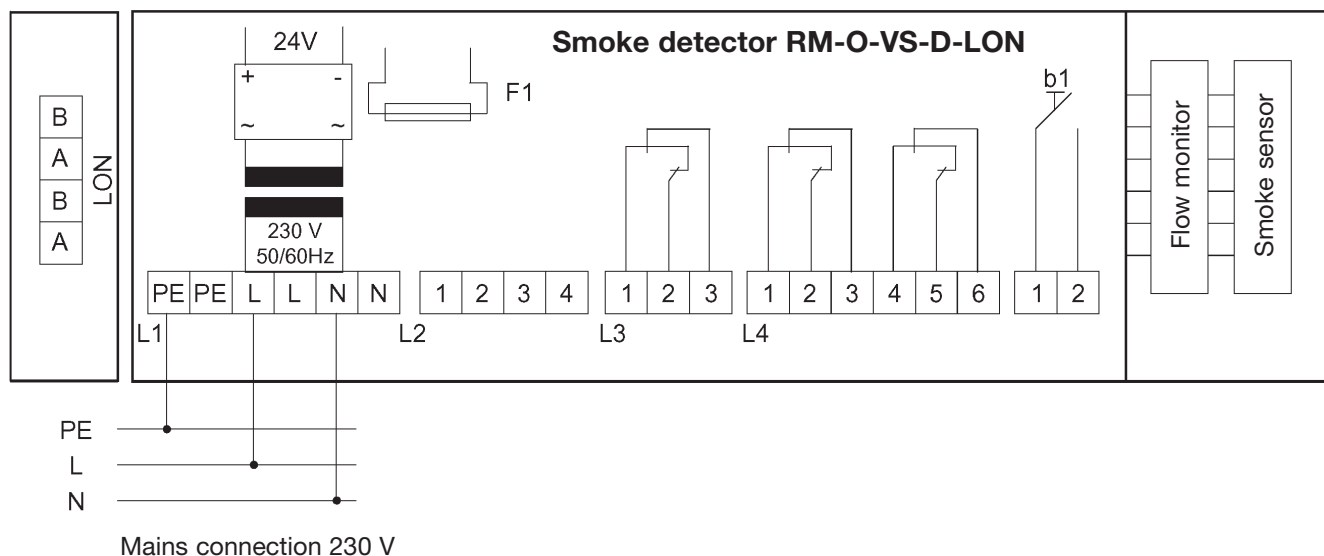

## 6. Specification text

### Specification text

Smoke detector (smoke sensing using optical light scatter principle) to prevent transfer of smoke via the ventilation ducting in air conditioning systems.

Suitable for control and release of fire and smoke dampers with General Building Approval equipped with electric or electro-pneumatic release mechanisms and working on the principle of power off to close.

### Essential characteristics:

- Can be used for air velocities of 1 m/s to 20 m/s
- With integral mains adapter (supply voltage 230 V, 50/60 Hz)
- Zero potential signal relay
- Integral signal lamps
- Sealed cover connected to casing with hinges
- Choice of four flow directions by rotation through 90°
- Easy to remove smoke sensor head (simple functional check)
- With contamination level indicator and “tracking” of sensitivity threshold (long service life)
- Air flow monitor (warning limit set at air velocity < 2 m/s)
- Annual maintenance
- Granted General Building Approval Z-78.6-67 by the German Institute for Structural Engineering, Berlin
- Compatible with any product and manufacturer
- Integrated bus connection via LON via FTT10A Transceiver

Manufacturer: Trox

Type: RM-O-VS-D-LON