

Gebrüder Trox GmbH

Heinrich-Trox-Platz
D-47504 Neukirchen-Vluyn
Telephone +49/28 45/2 02-0
Telefax +49/28 45/2 02-2 65
e-mail trox@trox.de
www.troxtechnik.com

Labcontrol Automation and System Technology LON-WA5/B

PI/7.2/4/EN/1



1 Application

The LON-WA5/B IP 65 is used as a coupling module between the LonWorks[®] and the analogue technology. It enables the integration of analogue volume flow controllers into a LonWorks[®] network.

During the conversion of functionalities, only standard network variables (SNVT) are used so that the LON-WA5/B can be integrated flexibly and simply into primary systems.

The module is a set volume flow rate generator, an actual value measurement component and an operating mode switch for a subsequent volume flow rate controller. The actual volume flow control takes place in the connected Belimo, Gruner, Siemens or Sauter controller.

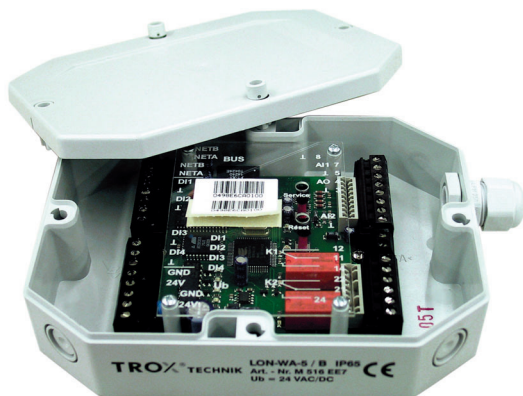

2 Technical data

Supply voltage:

24 VAC \pm 15 %, 50/60 Hz
Double terminals for loopthrough

Power consumption:

3.5 VA

Inputs:

2 analogue inputs 0 – 10 V DC
4 digital inputs for potential free switch contacts

Outputs:

1 analogue output 0 – 10 V DC
2 digital outputs (change-over contact relay)

LON Interface:

4 LON Connection terminals
FTT10 free topology

Protection:

IP 65

Software application:

The available applications (xif/apb file) can be downloaded from Internet at www.trox.de.

Connection terminals:

Supply, bus, digital and analogue signals with 90° screw terminals for 0.08 mm² – 2.5 mm² with polarity safe plug socket.

Casing:

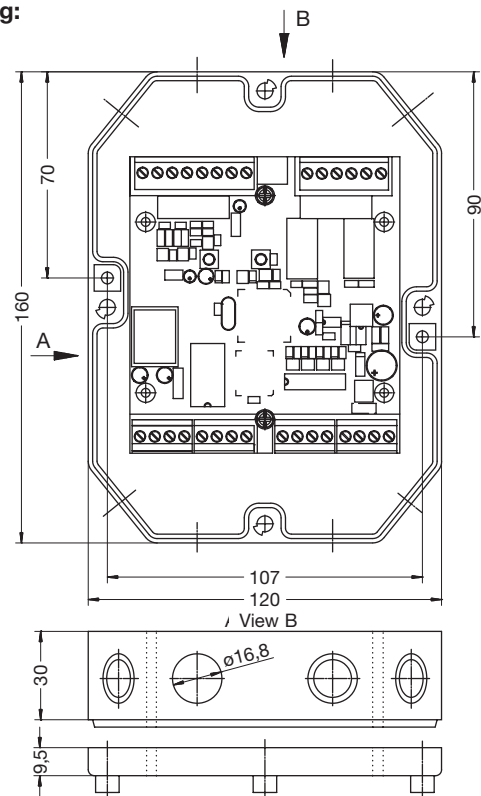

3 Functionality

The LON-WA5/B has standard functionalities in order to transfer analogue signals from volume flow rate controllers to a LonWorks network. The module is used to measure actual values and to transmit setpoints through the LON, as well as for the operating mode change-over. The various standard volume flow rate controllers of type Gruner, Belimo, Siemens and Sauter are connected directly to the LON-WA5/B. The various changeovers between the operating modes in single control units are provided by an adapter circuit board, which is plugged depending upon the type of the controller type into the LON-WA5/B.

Operating mode

Different types of operating modes are available. The possibilities are as follows:

- SNVT_hvac_overrid
- SNVT_occupancy

taken from the LonMark specification 8010 "VAV controller". Additionally, the desired operating mode can be set through the SNVT_state and the four digital inputs.

The following operating modes can be defined for the volume flow rate controller:

- Variable operation
- Min operation
- Max operation
- Full shut-off

In order to ensure a perfect functioning of the LON-WA5/B, the analogue input and the analogue output must be configured depending on the volume flow rate controller.

Analogue output characteristic

For the analogue output, it is possible to define a characteristic and an operating range. It is thus possible, during the corresponding configuration of the volume flow rate controller (0 – 100 %), to control any desired set value in the operating range over LON. For this reason, the volume flow rate controller with the assembled LON-WA5/B is always programmed starting from $0 - \dot{V}_{Nom}$ during factory calibration. The characteristic is determined by the adjusted minimum and maximum flow rate and the appropriate voltage range (0 – 10 V DC / 2 – 10 V DC) of the analogue volume flow rate controller. The respective operating range can be then selected within the minimum and maximum limits of the characteristic. The actual volume flow rate results from the selected operating range and the current operating mode. Set values which are outside of the configured operating range are set to a minimum or maximum volume flow rate.

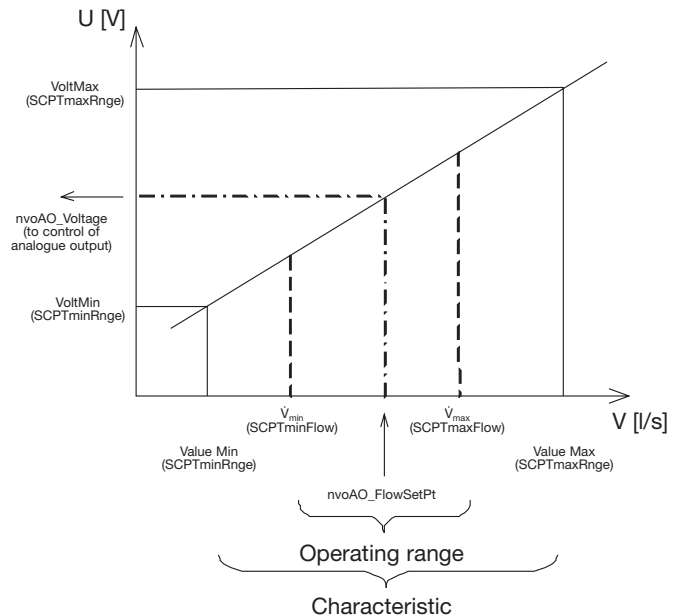

Analogue input characteristic

The analogue input characteristic is defined from the minimum and maximum volume flow rate and the set voltage range of the volume flow rate controller.

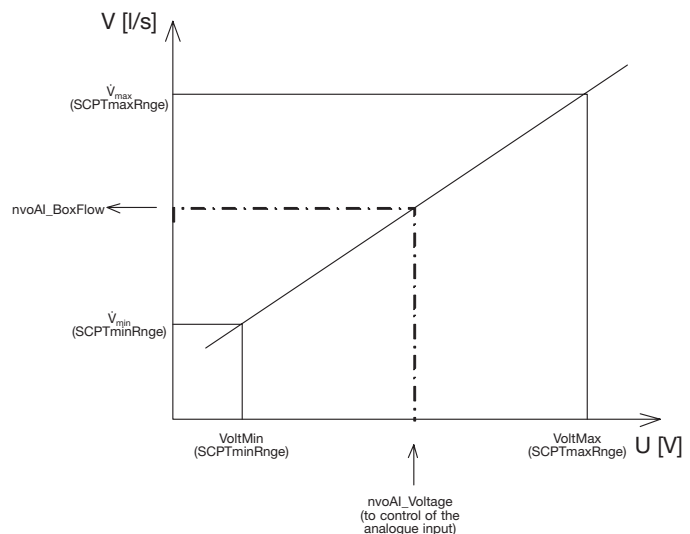

4 Description of the function object

The LON node consists of a node object and a virtual functional block. The virtual functional block consists of network variables and configuration parameters. All variables and parameters are based on standard network variables (SNVT) so that a simple integration of the LON-WA5/B is ensured into the LonWorks network.

4.1 Network variables

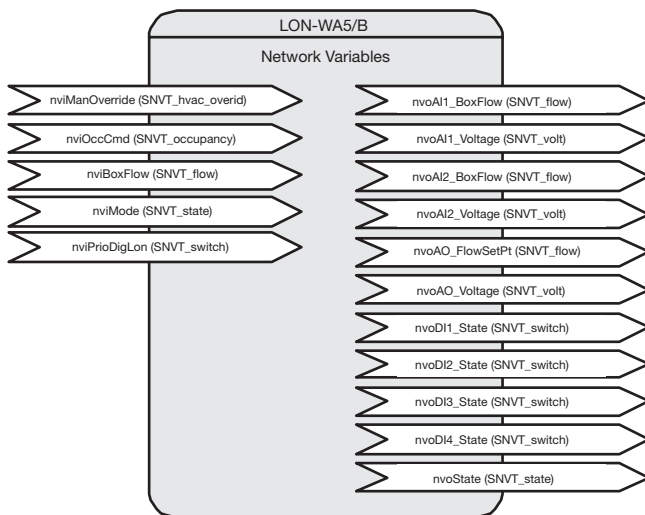

nviManOverride

SNVT type: SNVT_hvac_overid

Function:

A volume flow set point or a defined operating mode of the volume flow rate controller can be set through this input.

The variable contains the fields:

- state
- percent
- flow

The following settings are supported:

Valid values status:

- HVO_Off: no function
- HVO_Flow_Value: Sets the set value to the flow field value based on the adjusted operating range
- HVO_Flow_Percent: Sets the set value to the percent field value based on the adjusted operating range
- HVO_Close: The output is set to 0 V and both relays are activated in order to force the damper blade in the full shut-off position
- HVO_Minimum: The volume flow rate controller controls \dot{V}_{min}
- HVO_Maximum: The volume flow rate controller controls \dot{V}_{max}

Note:

To ensure a perfect functioning of the nviManOverride variable through the Change Format, the format of SNVT_hvac_overid#SI must be changed to SNVT_hvac_overid#SI_LO.

nviOccCmd

SNVT type: SNVT_occupancy

Function:

The four possible operating modes of the volume flow rate controller can be set through this input. It can be configured freely with the aid of the appropriate SCPT-direction (nviOccCmd) configuration parameter at which predefined setting which operation mode is executed.

Default setting:

- OC_Nul: no function
- OC_Occupied: The volume flow rate controller controls \dot{V}_{max}
- OC_Unoccupied: The volume flow rate controller controls \dot{V}_{min}
- OC_Bypass: no function
- OC_Standby: The volume flow rate controller controls \dot{V}_{min}

nviMode

SNVT type: SNVT_state

Function:

Determines the function of the volume flow rate controller.

Bit	Function	0	1
1	Day operation	inactive	active
2	Reduced operation	inactive	active
3	Emergency operation	inactive	active
4	Close	inactive	active
12	Close	inactive	active
13	Emergency operation	inactive	active
14	Reduced operation	inactive	active
15	Day operation	inactive	active

It can be configured freely with the aid of the appropriate SCPTdirection (nviMode) configuration parameter at which predefined setting which operation mode is executed.

nviBoxFlow

SNVT type: SNVT_Flow

Function:

The volume flow rate controller can set a variable volume flow setpoint within the limits of the specified operating range through the BoxFlow.

In order to be able to define the variable setpoint, either the nviOccCmd or nviMode input in the “variable” operating mode must be configured.

nviPrioDigLon

SNVT type: SNVT_switch

Function:

Determines the priority for the operating mode change-over via LON or the digital input.

Value	State	Function
0.0	0	Priority DI
> 0.0	1	Priority LON

In the default setting, the digital inputs have priority over the LON inputs. The DI 1 has thereby the highest priority. The LON inputs have the following priority among themselves:

- nviManOverride
- nviOccCmd
- nviMode

As soon as a valid value is set through an input, the following inputs are ignored.

nvoAI1_BoxFlow

SNVT type: SNVT_flow

Function:

Output actual volume flow rate analogue input AI1.

nvoAI1_Voltage

SNVT type: SNVT_volt

Function:

Output analogue input voltage AI1.

nvoAI2_BoxFlow

SNVT type: SNVT_flow

Function:

Output actual volume flow rate analogue input AI2.

nvoAI2_Voltage

SNVT type: SNVT_volt

Function:

Output analogue input voltage AI2.

nvoAO_FlowSetPt

SNVT type: SNVT_flow

Function:

Output volume flow set point analogue output.

nvoAO_Voltage

SNVT type: SNVT_volt

Function:

Output analogue output voltage.

nvoDI1_State

SNVT type: SNVT_switch

Function:

Status digital input DI1.

Value	State	Function
0.0	0	inactive
100.0	1	active

nvoDI2_State

SNVT type: SNVT_switch

Function:

Status digital input DI2.

Value	State	Function
0.0	0	inactive
100.0	1	active

nvoDI3_State

SNVT type: SNVT_switch

Function:

Status digital input DI3.

Value	State	Function
0.0	0	inactive
100.0	1	active

nvoDI4_State

SNVT type: SNVT_switch

Function:

Status digital input DI4.

Value	State	Function
0.0	0	inactive
100.0	1	active

nvoState

SNVT type: SNVT_state

Function:

Output of actual operating mode and DI/DO status.

Bit	Operating mode	0	1
0	Variable	inactive	active
1	Min	inactive	active
2	Max	inactive	active
3	Close	inactive	active
4	Flow_value (nviManOverride)	inactive	active
5	Flow_percent (nviManOverride)	inactive	active
10	Relay 2	inactive	active
11	Relay 1	inactive	active
12	DI 4	inactive	active
13	DI 3	inactive	active
14	DI 2	inactive	active
15	DI 1	inactive	active

4.2 Configuration parameters

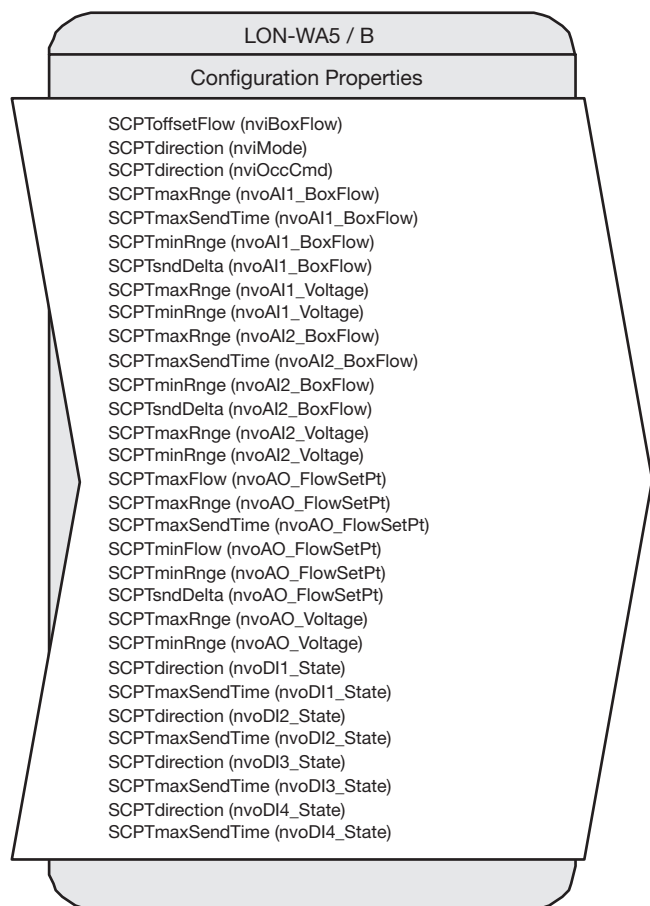

SCPToffsetFlow (nviBoxFlow)

SCPT type: SCPT_offsetFlow

Function:

Through the configuration parameter it is possible to input an offset volume flow rate, which can be added or subtracted from the volume flow set point.

This configuration allows the connection of a master-slave circuit between two volume flow rate controllers with LON-WA5/B and with a constant volume flow difference.

SCPTdirection (nviMode)

SCPT type: SCPT_direction

Function:

Configuration of the operating mode, which is to be carried out with the respective setting of the nvi_mode input variable.

Bit	Operating mode	Setting	0	1
0	Variable	Day	inactive	active
1	Min		inactive	active
2	Max		inactive	active
3	Close	Reduced	inactive	active
4	Variable		inactive	active
5	Min		inactive	active
6	Max	Emergency operation	inactive	active
7	Close		inactive	active
8	Variable		inactive	active
9	Min	Close	inactive	active
10	Max		inactive	active
11	Close		inactive	active
12	Variable	Close	inactive	active
13	Min		inactive	active
14	Max		inactive	active
15	Close		inactive	active

Note:

Per each setting possibility, only one operating mode may be selected.

SCPTdirection (nviOccCmd)

SCPT type: SCPT_direction

Function:

Configuration of the operating mode, which is to be carried out with the respective setting of the nvi_OccCmd input variable.

Bit	Operating mode	Setting	0	1
0	Variable	Occupied	inactive	active
1	Min		inactive	active
2	Max		inactive	active
3	Close	Un-occupied	inactive	active
4	Variable		inactive	active
5	Min		inactive	active
6	Max	Bypass	inactive	active
7	Close		inactive	active
8	Variable		inactive	active
9	Min	Standby	inactive	active
10	Max		inactive	active
11	Close		inactive	active
12	Variable	Standby	inactive	active
13	Min		inactive	active
14	Max		inactive	active
15	Close		inactive	active

Note:

Per each setting possibility, only one operating mode may be selected.

Configuration of analogue input 1:

SCPTmaxRnge (nvoAI1_BoxFlow)

SCPT type: SCPT_maxRnge

Function:

Maximum limitation of the characteristic for the analogue input 1.

SCPTmaxSendTime (nvoAI1_BoxFlow)

SCPT type: SCPT_maxSendTime
Function:
Time interval after that the volume flow rate is transmitted again.

SCPTminRnge (nvoAI1_BoxFlow)

SCPT type: SCPT_minRnge
Function:
Minimum limitation of the characteristic for the analogue input 1.

SCPTsndDelta (nvoAI1_BoxFlow)

SCPT type: SCPT_sndDelta
Function:
Output tolerance for a change of volume flow rate.

SCPTmaxRnge (nvoAI1_Voltage)

SCPT type: SCPT_maxRnge
Function:
Upper voltage level analogue input 1.

SCPTminRnge (nvoAI1_Voltage)

SCPT type: SCPT_minRnge
Function:
Lower voltage level analogue input 1.

Configuration of analogue input 2:

SCPTmaxRnge (nvoAI2_BoxFlow)

SCPT type: SCPT_maxRnge
Function:
Maximum limitation of the characteristic for the analogue input 2.

SCPTmaxSendTime (nvoAI2_BoxFlow)

SCPT type: SCPT_maxSendTime
Function:
Time interval after that the volume flow rate is transmitted again.

SCPTminRnge (nvoAI2_BoxFlow)

SCPT type: SCPT_minRnge
Function:
Minimum limitation of the characteristic for the analogue input 2.

SCPTsndDelta (nvoAI2_BoxFlow)

SCPT type: SCPT_sndDelta
Function:
Output tolerance for a change of volume flow rate.

SCPTmaxRnge (nvoAI2_Voltage)

SCPT type: SCPT_maxRnge
Function:
Upper voltage level analogue input 2.

SCPTminRnge (nvoAI2_Voltage)

SCPT type: SCPT_minRnge
Function:
Lower voltage level analogue input 2.

Configuration of analogue output:

SCPTmaxFlow (nvoAO_FlowSetPt)

SCPT type: SCPT_maxFlow
Function:
Maximum limitation for the volume flow rate in the operating range.

SCPTmaxRnge (nvoAO_FlowSetPt)

SCPT type: SCPT_maxRnge
Function:
Maximum limitation of the characteristic for the analogue output.

SCPTmaxSendTime (nvoAO_FlowSetPt)

SCPT type: SCPT_maxSendTime
Function:
Time interval after that the volume flow set value is transmitted again.

SCPTminFlow (nvoAO_FlowSetPt)

SCPT type: SCPT_minFlow
Function:
Minimum limitation for the volume flow rate in the operating range.

SCPTminRnge (nvoAO_FlowSetPt)

SCPT type: SCPT_minRnge
Function:
Minimum limitation of the characteristic for the analogue output.

SCPTsndDelta (nvoAO_FlowSetPt)

SCPT type: SCPT_sndDelta
Function:
Output tolerance for a change of volume flow rate.

SCPTmaxRnge (nvoAO_Voltage)

SCPT type: SCPT_maxRnge
Function:
Upper voltage level analogue output.

SCPTminRnge (nvoAO_Voltage)

SCPT type: SCPT_minRnge
Function:
Lower voltage level analogue output.

Configuration of digital inputs

SCPTdirection (nvoDI1_State)

SCPT type: SCPT_direction

Function:

Configuration of the operating mode, which is to be carried out through the digital input 1.

Bit	Operating mode	Adjustment	0	1
0	Variable	DI1	inactive	active
1	Min		inactive	active
2	Max		inactive	active
3	Close		inactive	active

SCPTmaxSendTime (nvoDI1_State)

SCPT type: SCPT_maxSendTime

Function:

Time interval after that the DI1 status is transmitted again.

SCPTdirection (nvoDI2_State)

SCPT type: SCPT_direction

Function:

Configuration of the operating mode, which is to be carried out through the digital input 2.

Bit	Operating mode	Adjustment	0	1
0	Variable	DI2	inactive	active
1	Min		inactive	active
2	Max		inactive	active
3	Close		inactive	active

SCPTmaxSendTime (nvoDI2_State)

SCPT type: SCPT_maxSendTime

Function:

Time interval after that the DI2 status is transmitted again.

SCPTdirection (nvoDI3_State)

SCPT type: SCPT_direction

Function:

Configuration of the operating mode, which is to be carried out through the digital input 3.

Bit	Operating mode	Adjustment	0	1
0	Variable	DI3	inactive	active
1	Min		inactive	active
2	Max		inactive	active
3	Close		inactive	active

SCPTmaxSendTime (nvoDI3_State)

SCPT type: SCPT_maxSendTime

Function:

Time interval after that the DI3 status is transmitted again.

SCPTdirection (nvoDI4_State)

SCPT type: SCPT_direction

Function:

Configuration of the operating mode, which is to be carried out through the digital input 4.

Bit	Operating mode	Adjustment	0	1
0	Variable	DI4	inactive	active
1	Min		inactive	active
2	Max		inactive	active
3	Close		inactive	active

SCPTmaxSendTime (nvoDI4_State)

SCPT type: SCPT_maxSendTime

Function:

Time interval after that the DI4 status is transmitted again.

5 Connection diagram

The LON-WA5/B can be wired directly with the volume flow rate controller showed below. Depending upon the volume flow rate controller, the suitable adapter circuit board must be inserted into the module. The relay outputs are switched off in the inserted circuit board.

In the assembled LON-WA5/B, the wiring is performed by Trox. If the LON-WA5/B is supplied loose, the wiring must be performed by customer.

5.1 Belimo NMV-D2M

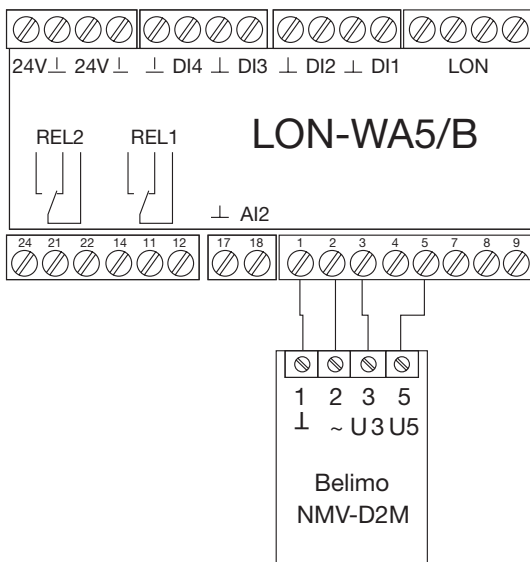

NMV-D2 connection cable (approx. length: 50 cm) available in the controller.

5.2 Gruner 227 V

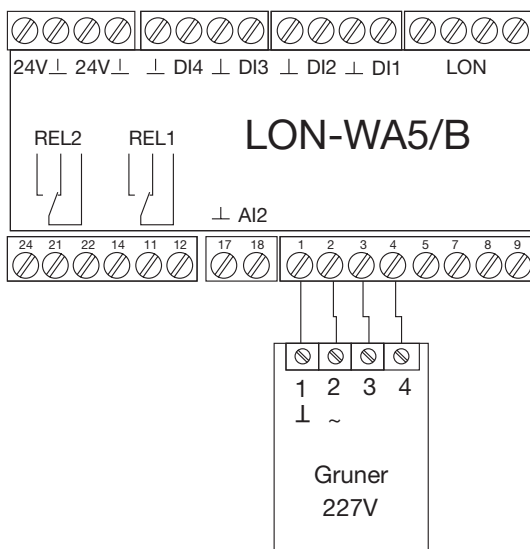

227 V connection cable (approx. length: 50 cm) available in the controller.

5.3 Belimo VRD2 / VRP

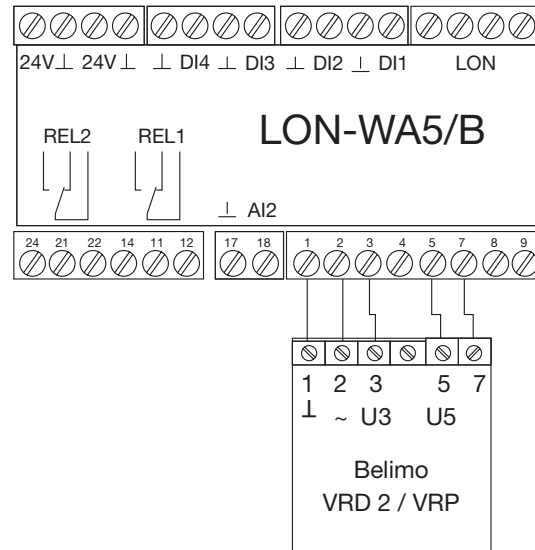

VRD2 connection cable / VRP supplied by customer.

5.4 Siemens GLB

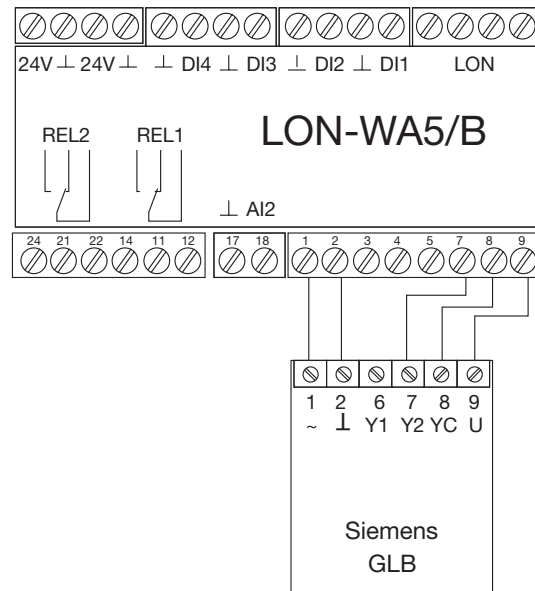

GLB connection cable (approx. length: 50 cm) available in the controller.

5.5 TVR Easy

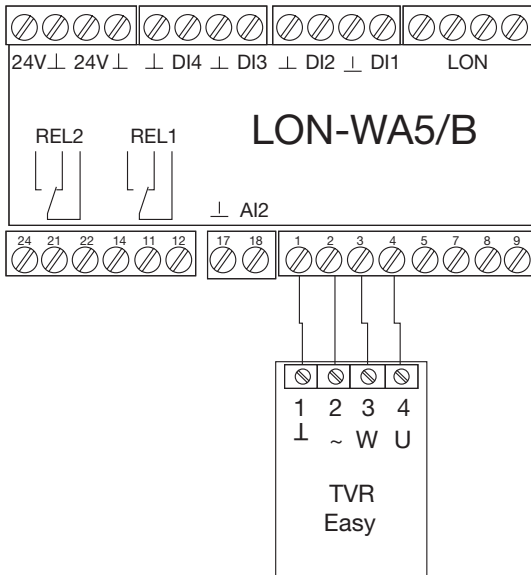

TVR Easy connection cable supplied by customer.

5.6 Sauter RLE 150/151/152

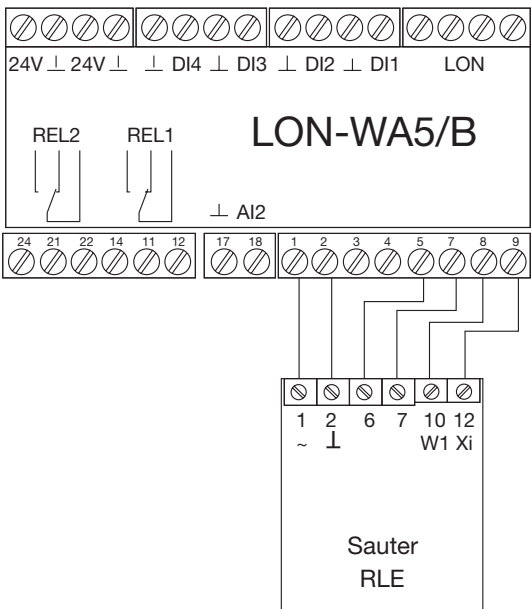

RLE connection cable supplied by customer.

6 Specification Text

LON coupling module for transferring analogue signals from volume flow rate controllers to a LonWorks network. The module is used to measure actual values and to transmit setpoints through the LON, and for the operating mode change-over. The standard volume flow rate controller is connected directly to the module. The various changeovers between the operating modes in the single controller types is provided by an adapter circuit board. All variables and parameters are based on standard network variables types (SNVT).

The changeover of the four operating modes

- Variable operating mode
- \dot{V}_{\min} operating mode
- \dot{V}_{\max} operating mode
- Supply

can take place in different types. It is possible to implement the operating modes through the

- SNVT_hvac_overid
- SNVT_occupancy
- SNVT_state.

Technical data:

- 24 V AC +/-15 % Distribution voltage, 50,60 Hz with double terminals for loopthrough
- 2 analogue inputs 0 – 10 V DC
- 4 digital inputs
- 1 analogue output 0 – 10 V DC
- 2 digital outputs (change-over contact relay)
- 4 LON connection terminals
- FTT10 Transceiver
- Protection IP 65
- Connection terminals as 90° screw terminals for 0.08 mm² – 2.5 mm² implemented with polarity safe plug socket

Make: Trox

Type: LON-WA5/B