

# Rectangular Splitter Attenuators

Type MSA100 and MSA200

## Splitters

Type MKA100 and MKA200

Energy-saving splitter hygiene design

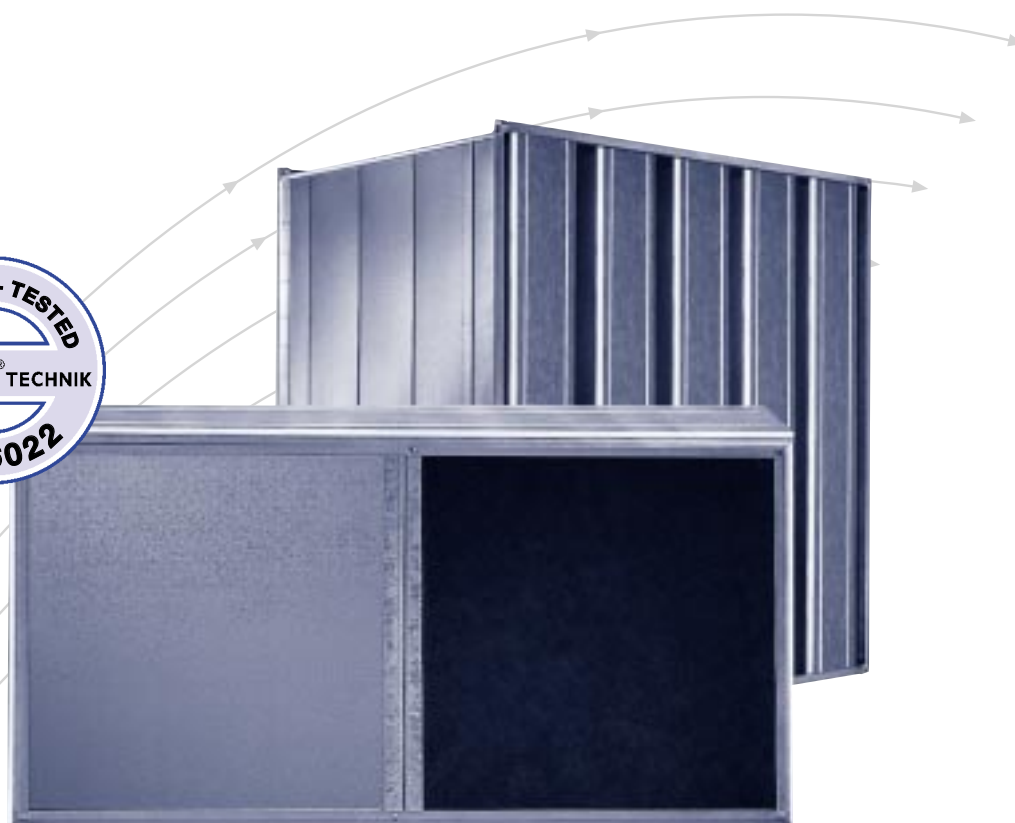

# TROX® TECHNIK

TROX GmbH  
Heinrich-Trox-Platz  
D-47504 Neukirchen-Vluyn

Telephone +49/28 45/2 02-0  
Telefax +49/28 45/2 02-2 65  
e-mail trox@trox.de  
www.troxtechnik.com

# Contents · Description

Description _____	2	Quick selection tables _____	6
Construction · Weight _____	3	Insertion loss _____	8
Construction · Dimensions · Accessories _____	4	Air-regenerated noise · Pressure drop _____	10
Installation details · Nomenclature _____	5	Order details MSA · MKA _____	12

Hygiene design VDI 6022



With the coming into effect of VDI 6022, real hygiene requirements have been placed for the first time on air conditioning and ventilation systems.

The entire air conditioning and ventilation system must consist of materials in the ventilated area which do not emit either health endangering materials or culture mediums for micro organisms. It must be ensured that no source of unhealthy and smelling air components can be loaded in the air.

TROX splitters and splitter attenuators are suitable for use in air conditioning and ventilation systems certified and compliant to VDI 6022 Part 1 and Part 3 as well as to DIN 1946 Part 2 and Part 4 and VDI 3803.

Energy saving by reduced pressure drop

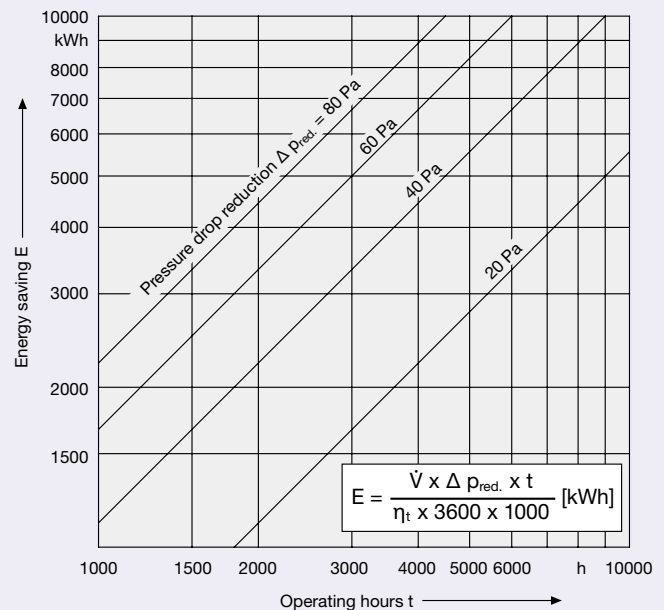

The diagram is based on an overall efficiency  $\eta_t$  of 0.8 of the fan and an air volume flow rate of 80,000 m<sup>3</sup>/h.

The turbulences of the sound attenuator inlet and outlet are reduced by the aerodynamically profiled frame of the splitters. The pressure drop is reduced up to 30 %.

It is thus possible to select smaller gaps and a shorter silencer.

As a result, a more compact design results in direct savings of the operating costs and/or in space saving. When using additional necessary aerodynamic profiles, acoustic and ineffective splitters lengths can be avoided.

The special design causes an increased insertion loss in the area of fan noises compared to real absorption splitters.

## Design versions

The splitters of Series M in perforated-plate design differ only slightly from the standard version described here with respect to insertion loss, air-regenerated noise and pressure drop; the data is available in a separate description.

All other design versions (e.g., other splitter thickness) or special versions are supplied without a suitability certificate unless special condition have been agreed upon.

Weight MSA100 in kg · Dimensions									
Length L in mm	Height H in mm	Width B in mm							
		200	400	600	800	1000	1200	1400	1600
		with max. number of splitters n							
		1	2	3	4	5	6	7	8
500	300	9	13	18	22	27	32	36	41
	600	14	20	26	33	39	45	52	58
	900	19	27	35	43	51	59	67	76
	1200	24	34	44	53	63	73	83	93
	1500	29	40	52	64	75	87	99	110
1800	34	47	61	74	87	101	114	128	
750	300	11	17	23	30	36	42	48	54
	600	18	26	35	43	51	60	68	76
	900	24	35	46	56	67	78	88	99
	1200	31	44	57	70	83	95	108	121
	1500	37	53	68	83	98	113	129	144
1800	44	61	79	96	114	131	149	166	
1000	300	14	21	29	37	44	52	60	67
	600	22	32	43	53	63	74	84	95
	900	30	43	56	69	83	96	109	122
	1200	38	54	70	86	102	118	134	150
	1500	46	65	84	102	121	140	158	177
1800	54	76	97	119	140	162	183	205	
1250	300	16	25	35	44	53	62	71	80
	600	26	38	51	63	76	88	100	113
	900	36	51	67	83	98	114	130	145
	1200	45	64	83	102	121	140	159	178
	1500	55	77	99	122	144	166	188	211
1800	65	90	116	141	167	192	218	243	
1500	300	19	30	40	51	61	72	83	93
	600	30	44	59	73	88	102	117	131
	900	41	59	78	96	114	132	151	169
	1200	52	74	96	118	140	162	184	206
	1500	64	89	115	141	167	193	218	244
1800	75	104	134	163	193	223	252	282	

Weight incl. perforated-plate cover: + 2.5 x n x H x L. Weights for lengths over 1500 mm must be added up in the modular dimension.

Weight MKA100 in kg · Dimensions						
Length L in mm	Height H in mm					
	300	600	900	1200	1500	1800
500	2	4	6	8	9	11
750	3	6	8	10	12	15
1000	4	7	10	12	15	18
1250	5	8	11	15	18	21
1500	6	9	13	17	21	25

Weight incl. perforated-plate cover: + 2.5 x H x L. Weights for lengths and heights outside the table must be added up in the modular dimension.

Weight MSA200 in kg · Dimensions									
Length L in mm	Height H in mm	Width B in mm							
		400	800	1200	1600	2000	2400	2400	2400
		with max. number of splitters n							
		1	2	3	4	5	6	7	8
500	300	12	20	28	36	43	51	55	58
	600	18	28	39	49	60	70	76	83
	900	24	37	50	63	76	89	97	106
	1200	29	45	61	76	92	107	119	130
	1500	35	53	71	90	108	126	140	153
1800	41	62	82	103	124	144	161	177	
750	300	16	26	37	48	58	69	74	79
	600	23	37	51	65	79	93	101	109
	900	31	48	65	83	100	117	129	140
	1200	39	59	80	100	121	141	156	171
	1500	46	70	94	118	142	166	184	202
1800	54	81	108	135	163	190	211	233	
1000	300	19	33	46	59	73	86	92	98
	600	29	46	64	81	98	116	126	136
	900	38	60	81	103	124	146	160	174
	1200	48	73	99	124	150	176	194	212
	1500	57	87	116	146	176	205	228	250
1800	67	100	134	168	202	235	262	288	
1250	300	23	39	55	71	87	103	110	118
	600	34	55	76	97	118	139	151	163
	900	46	71	97	123	148	174	191	208
	1200	57	87	118	149	179	210	232	254
	1500	68	104	139	174	210	245	272	299
1800	79	120	160	200	240	281	313	344	
1500	300	27	45	64	83	101	120	129	138
	600	40	64	88	113	137	161	176	190
	900	53	83	113	143	173	203	223	243
	1200	66	102	137	173	208	244	269	295
	1500	79	120	161	203	244	285	316	348
1800	92	139	186	233	279	326	363	400	

Weight incl. perforated-plate cover: + 2.5 x n x H x L. Weights for lengths over 1500 mm must be added up in the modular dimension.

Weight MKA200 in kg · Dimensions						
Length L in mm	Height H in mm					
	300	600	900	1200	1500	1800
500	4	6	9	11	14	16
750	5	8	12	15	18	21
1000	6	10	14	18	23	27
1250	7	12	17	22	27	32
1500	9	14	20	26	31	37

Weight incl. perforated-plate cover: + 2.5 x H x L. Weights for lengths and heights outside the table must be added up in the modular dimension.

# Construction · Dimensions · Accessories

## Splitters

- Aerodynamically shaped frame of galvanised sheet steel, stiffened by crimping.
- Absorption material (highly bio-degradable, no health risk) with laminated non-woven glass fibre fabric to provide protection against abrasion at air velocities of up to 20 m/s; rot-proof and moisture-repellent impregnation, non-flammable according to DIN 4102 A2.
- External lambda panels and internal partitioning panels of galvanised sheet steel.
- Operating temperature up to 100 °C.
- Can be installed in any position up to a height of and including 1200 mm.
- Fulfills the hygiene requirements of VDI 6022, DIN 1946 part 2 and part 4 as well as of VDI 3803.

## Casing

- Folded casing of galvanised sheet steel stiffened by crimping; larger dimensions additionally with reinforcing strip.
- Connection frame air duct section (30 mm); alternatively, a frame perforated at the factory of galvanised angular steel 35 by 5 mm available (Please indicate this in the order). In the case of division of the B dimension and/or H dimension, the sound attenuators are delivered with a connection frame of galvanised angular steel as a standard.

Available undivided maximum size B = 2400 mm, H = 1800 mm, L = 1500 mm.

Standard height-modular dimension for splitter and casing: 100 mm.

Splitter MKA...

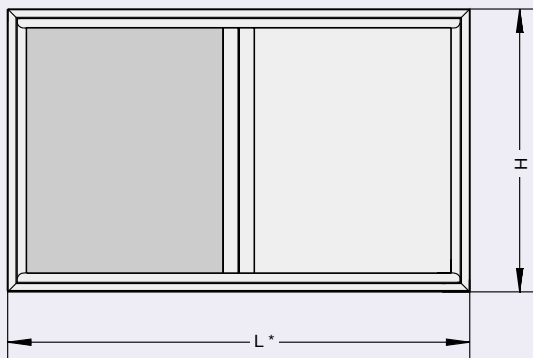

Splitter attenuator MSA...

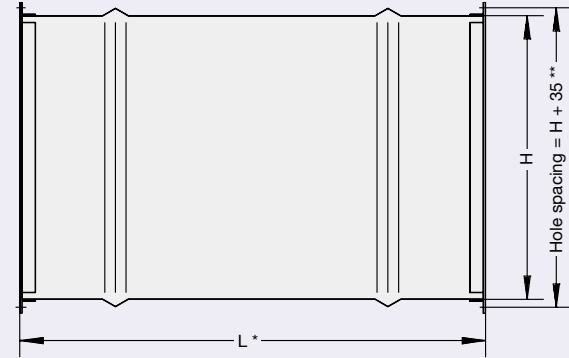

## Accessories

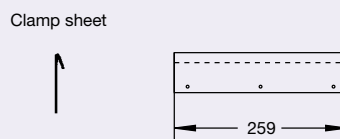
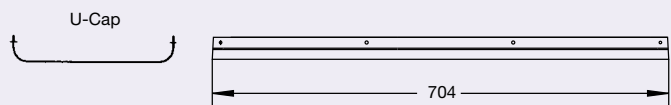
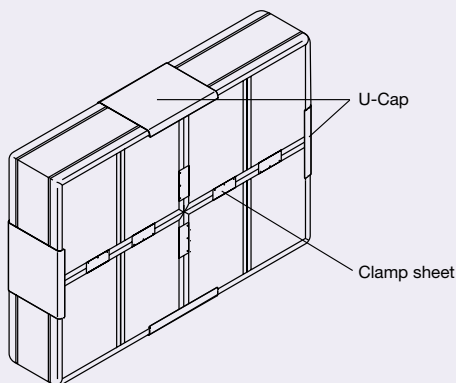

H or L ≤ 750 mm  
without clamp sheet

H or L 751 – 1000 mm  
1 clamp sheet on each side

H or L ≥ 1000 mm  
2 clamp sheets recommended

\* The direction of the L dimension is always the same as the direction in which the sound passes. Please remember this with respect to vertical air ducting!

\*\* The spacing applies only to connection frames of air duct section (30 mm).

# Installation Details · Nomenclature

## Installation details

If splitters are supplied as an installation kit for a sound attenuator or if splitters and attenuator casing are supplied separately, the following paragraph shall be part of the supply contract:

“The specified performance data is achieved only if the installation details of the manufacturer and the generally accepted rules of engineering are complied with.”

Installation details are specifications, including types and dimensions, in TROX quotations, order confirmations and technical documentation.

## Nomenclature

B	in mm:	Width
H	in mm:	Height
L	in mm:	Length
d	in mm:	Splitter thickness
s	in mm:	Airway width
n	:	Number of adjacent splitters in the B dimension
V	in l/s resp. in m <sup>3</sup> /h:	Volume flow rate
v <sub>s</sub>	in m/s:	Air velocity in the airway
Δp	in Pa:	Pressure drop
f <sub>m</sub>	in Hz:	Octave centre frequency
D <sub>e</sub>	in dB:	Insertion loss
L <sub>W</sub>	in dB:	Sound power level of the air-regenerated noise in duct
L <sub>W</sub>	in dB(A):	A-weighted sound power level of the air-regenerated noise in duct
L <sub>S</sub>	in dB:	Correction values for L <sub>W</sub> at B x H ≠ 1 m <sup>3</sup>

### Arrangement of partitioning panel MKA100...

Opposing partitioning panels

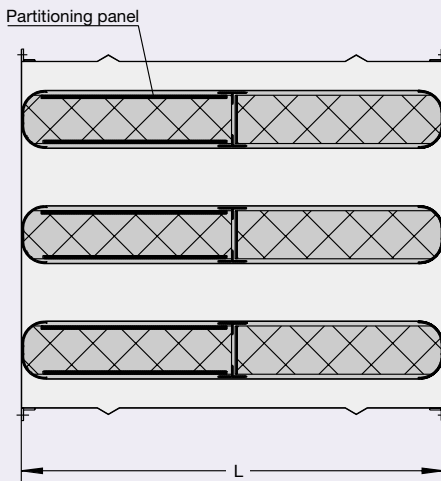

### Arrangement of partitioning panel MKA200...

Offset partitioning panels

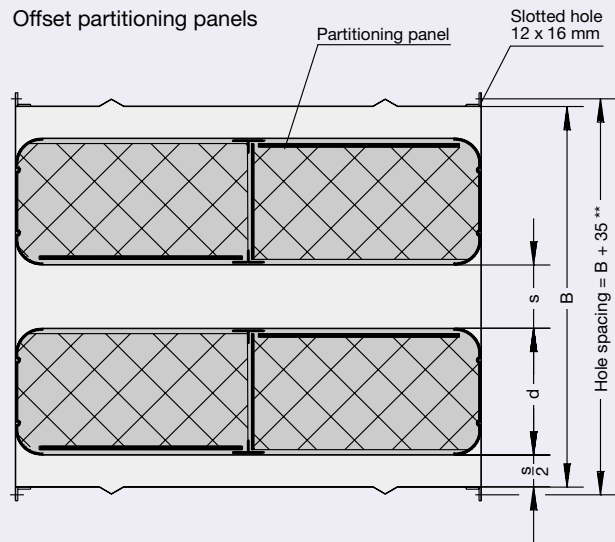

### Entry flow condition

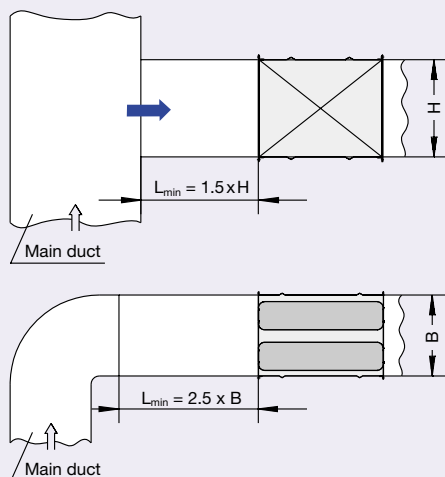

### Max. stacking height (without additional load)

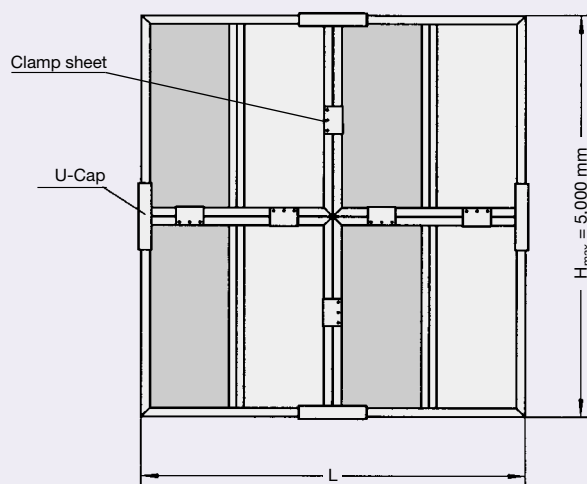

To avoid an overproportional pressure drop and unstable air-regenerated noise, horizontal installation is recommended (up to heights H<sub>max.</sub> = 1200 mm possible).

\*\* The spacing and dimension of slotted holes are valid only to connection frames of air duct section (30 mm).

# Quick Selection MSA100 (125...4,700 l/s)

## Quick selection table MSA100

The volume flow rates specified in the table apply to a pressure drop of approx. 50 Pa.

$L_w$  is the A-weighted sound power level of the air-regenerated noise in the duct at the attenuator outlet level, applicable to  $B \times H = 1 \text{ m}^2$ .

For other surface areas, the value must be corrected with  $L_s$ .

Volume flow rate $\dot{V}$ at $\Delta p = 50 \text{ Pa}$															
n	Attenuator width B in mm, height H* in mm		Insertion loss $D_e$ at 250 Hz in dB												$L_s$ in dB
			10		18		26		34		43		50		
			Attenuator length L in mm				Volume flow rate $\dot{V}$ in								
			500		1000		1500		2000		2500		3000		
		l/s	m <sup>3</sup> /h	l/s	m <sup>3</sup> /h	l/s	m <sup>3</sup> /h	l/s	m <sup>3</sup> /h	l/s	m <sup>3</sup> /h	l/s	m <sup>3</sup> /h	l/s	m <sup>3</sup> /h
1	150	300	193	696	169	610	153	549	140	504	130	468	122	439	-13
		600	391	1408	345	1241	312	1122	287	1032	267	960	250	902	-10
		900	589	2120	520	1872	471	1695	433	1560	403	1453	379	1365	-9
2	300	300	387	1393	339	1220	305	1099	280	1008	260	936	244	878	-10
		600	782	2816	689	2482	623	2244	573	2063	533	1920	501	1803	-7
		900	1178	4240	1040	3744	941	3389	866	3119	807	2905	758	2730	-6
3	450	300	580	2089	508	1830	458	1648	420	1512	390	1404	366	1317	-9
		600	1173	4224	1034	3722	935	3365	860	3095	800	2880	751	2705	-6
		900	1767	6360	1560	5616	1412	5084	1300	4679	1210	4358	1137	4095	-4
4	600	300	774	2785	678	2440	610	2198	560	2016	520	1872	488	1756	-7
		600	1564	5632	1379	4963	1246	4487	1146	4126	1067	3840	1002	3606	-4
		900	2355	8479	2080	7488	1883	6778	1733	6239	1614	5810	1517	5459	-3
5	750	300	967	3482	847	3050	763	2747	700	2520	650	2341	610	2195	-6
		600	1956	7040	1723	6204	1558	5609	1433	5158	1333	4800	1252	4508	-3
		900	2944	10599	2600	9360	2354	8473	2166	7798	2017	7263	1896	6824	-2
6	900	300	1161	4178	1017	3660	916	3297	840	3024	780	2809	732	2634	-6
		600	2347	8448	2068	7445	1870	6731	1719	6189	1600	5760	1503	5410	-3
		900	3533	12719	3120	11232	2824	10167	2599	9358	2421	8715	2275	8189	-1
7	1050	300	1354	4874	1186	4270	1068	3846	980	3527	910	3277	854	3073	-5
		600	2738	9856	2413	8685	2181	7852	2006	7221	1867	6720	1753	6311	-2
		900	4122	14839	3640	13103	3295	11862	3033	10918	2824	10168	2654	9554	± 0
8	1200	300	1547	5571	1356	4880	1221	4395	1120	4031	1040	3745	976	3512	-4
		600	3129	11264	2757	9926	2493	8974	2292	8252	2133	7680	2004	7213	-1
		900	4711	16959	4160	14975	3766	13557	3466	12477	3228	11620	3033	10919	± 0
$L_w$		49		46		44		42		40		38		in dB(A)	
$v_s$ (approx.)		13.0		11.5		10.4		9.6		8.9		8.3		in m/s	

\* Standard-height-module dimension: 100 mm

# Quick Selection MSA200 (300...18,000 l/s)

Volume flow rate $\dot{V}$ at $\Delta p = 50$ Pa																	
n	Attenuator width B height H* in mm in mm		Insertion loss $D_0$ at 250 Hz in dB												$L_s$ in dB		
			12		22		31		41		49		50				
			Attenuator length L in mm														
			500		1000		1500		2000		2500		3000				
Volume flow rate $\dot{V}$ in																	
		l/s		m³/h		l/s		m³/h		l/s		m³/h		l/s		m³/h	
1	300	300	376	1354	349	1255	326	1175	308	1109	292	1052	279	1004	-10		
		600	760	2736	710	2555	668	2406	633	2281	604	2173	577	2079	-7		
		900	1144	4118	1071	3856	1011	3639	960	3454	915	3296	877	3157	-6		
2	600	300	752	2707	697	2510	653	2350	616	2217	585	2105	558	2008	-7		
		600	1520	5471	1419	5110	1337	4812	1267	4561	1207	4346	1155	4158	-4		
		900	2288	8235	2142	7712	2022	7277	1919	6909	1831	6591	1754	6314	-3		
		1200	3055	11000	2865	10315	2707	9743	2572	9258	2455	8838	2353	8471	-1		
		1500	3823	13764	3588	12917	3392	12210	3224	11607	3079	11085	2952	10628	±0		
3	900	1800	4591	16529	4311	15520	4077	14676	3877	13956	3704	13333	3552	12786	±0		
		300	1128	4061	1046	3765	979	3525	924	3326	877	3157	836	3011	-6		
		600	2280	8207	2129	7665	2005	7218	1900	6842	1811	6518	1732	6237	-3		
		900	3431	12353	3213	11568	3032	10916	2879	10363	2746	9887	2631	9470	-1		
		1200	4583	16499	4298	15472	4060	14615	3857	13887	3683	13257	3529	12706	±0		
		1500	5735	20646	5382	19376	5087	18314	4836	17410	4619	16628	4429	15943	+1		
4	1200	1800	6887	24793	6467	23280	6115	22014	5815	20934	5555	20000	5328	19180	+2		
		300	1504	5415	1394	5019	1305	4700	1232	4434	1169	4209	1115	4015	-4		
		600	3039	10942	2839	10220	2673	9625	2534	9122	2414	8691	2310	8316	-1		
		900	4575	16471	4285	15424	4043	14555	3838	13818	3662	13182	3508	12627	±0		
		1200	6111	21999	5730	20629	5413	19487	5143	18515	4910	17676	4706	16941	+2		
		1500	7647	27528	7176	25834	6783	24419	6448	23214	6159	22171	5905	21257	+3		
5	1500	1800	9183	33057	8622	31040	8153	29352	7753	27913	7407	26666	7104	25573	+3		
		300	1880	6768	1743	6274	1632	5875	1540	5543	1461	5261	1394	5019	-3		
		600	3799	13678	3549	12775	3342	12031	3167	11403	3018	10864	2887	10395	±0		
		900	5719	20588	5356	19280	5054	18194	4798	17272	4577	16478	4384	15784	+1		
		1200	7639	27499	7163	25786	6766	24359	6429	23144	6138	22095	5882	21177	+3		
		1500	9558	34410	8970	32293	8479	30524	8060	29017	7698	27713	7381	26571	+4		
6	1800	1800	11478	41321	10778	38800	10192	36690	9692	34891	9259	33333	8879	31966	+4		
		300	2256	8122	2091	7529	1958	7049	1848	6651	1754	6314	1673	6023	-3		
		600	4559	16413	4258	15330	4010	14437	3801	13683	3621	13037	3465	12474	±0		
		900	6863	24706	6427	23136	6065	21832	5757	20727	5493	19774	5261	18941	+2		
		1200	9166	32999	8595	30944	8120	29230	7715	27773	7365	26514	7059	25412	+3		
		1500	11470	41292	10764	38752	10175	36629	9672	34821	9238	33256	8857	31885	+4		
7	2100	1800	13774	49586	12933	46560	12230	44028	11630	41869	11111	39999	10655	38359	+5		
		300	2632	9476	2440	8784	2285	8224	2155	7760	2046	7366	1952	7027	-2		
		600	5319	19149	4968	17885	4679	16843	4434	15964	4225	15210	4042	14553	+1		
		900	8006	28823	7498	26992	7075	25471	6717	24181	6408	23069	6138	22098	+3		
		1200	10694	38499	10028	36101	9473	34102	9001	32402	8593	30933	8235	29648	+4		
		1500	13382	48174	12558	45210	11870	42734	11284	40624	10777	38799	10333	37199	+5		
8	2400	1800	16069	57850	15089	54320	14268	51366	13569	48847	12963	46666	12431	44752	+6		
		300	3008	10829	2789	10039	2611	9399	2463	8868	2338	8418	2231	8030	-1		
		600	6079	21884	5678	20440	5347	19249	5068	18245	4828	17382	4620	16632	+2		
		900	9150	32941	8569	30848	8086	29110	7677	27636	7324	26365	7015	25255	+3		
		1200	12222	43999	11461	41258	10826	38974	10286	37031	9820	35352	9412	33883	+5		
		1500	15293	55056	14352	51669	13566	48839	12897	46427	12317	44342	11809	42514	+6		
$L_w$		49		47		46		44		43		43		in dB(A)			
$v_s$ (approx.)		12.8		12.0		11.3		10.8		10.3		9.9		in m/s			

\* Standard-height-module dimension: 100 mm

# Insertion Loss MSA100

## Insertion loss $D_e$

All values were measured according to DIN EN ISO 7235 (1995) in the TROX Laboratory.

Linear interpolation between specified values is permitted.

## Test method

The Duct Reverberation Chamber Method was chosen from the test methods described in DIN EN ISO 7235.

In accordance with this method, a noise is applied to an empty duct the third octave level of which is measured in a connected reverberation chamber under defined conditions.

The attenuator to be tested is then inserted in the empty duct and the measurement is repeated. The difference between the two measurements is the "insertion loss  $D_e$ ".

On the basis of the measured values of the third octave, the measured octave values are then calculated.

Measured laboratory values above 50 dB are specified as 50 dB according to general practice.

The measurement with simultaneously flowing air as also defined in DIN EN ISO 7235 does not have to be performed with respect to sound attenuators used in air-conditioning and ventilation systems since the influence on the measured values is within the usual tolerances.

The acoustic measurements were carried out according to DIN EN 23741 (1991).

Insertion loss  $D_{e, \text{oct}}$  in dB

$f_m$ in Hz	Length L = 500 mm Airway s in mm						
	40	50	60	70	80	90	100
63	4	4	3	3	3	3	3
125	10	9	8	7	5	4	4
250	11	10	9	7	6	5	5
500	12	11	11	10	9	8	8
1 k	20	19	18	16	15	14	13
2 k	27	25	23	20	18	16	15
4 k	24	21	19	16	14	12	11
8 k	18	16	14	12	10	9	8

$f_m$ in Hz	Length L = 1000 mm Airway s in mm						
	40	50	60	70	80	90	100
63	5	5	4	4	4	4	3
125	12	11	11	11	9	8	8
250	20	18	16	14	12	10	9
500	22	20	19	17	15	14	13
1 k	31	29	27	25	23	22	21
2 k	37	34	32	28	25	23	21
4 k	32	28	26	22	19	17	15
8 k	26	22	20	17	14	12	11

$f_m$ in Hz	Length L = 1500 mm Airway s in mm						
	40	50	60	70	80	90	100
63	6	6	6	5	5	4	4
125	15	14	14	12	11	11	10
250	29	26	24	20	18	16	14
500	32	29	27	24	22	20	19
1 k	41	39	37	34	32	30	29
2 k	47	43	40	36	32	30	28
4 k	40	35	33	28	24	21	19
8 k	34	29	27	22	18	16	13

$f_m$ in Hz	Length L = 2000 mm Airway s in mm						
	40	50	60	70	80	90	100
63	7	7	7	6	6	5	5
125	18	17	16	15	13	13	12
250	38	34	32	27	24	21	19
500	41	38	36	32	29	26	24
1 k	50	48	46	43	40	38	36
2 k	50	50	49	44	40	37	34
4 k	48	43	39	33	29	25	22
8 k	42	36	33	27	22	19	16

$f_m$ in Hz	Length L = 2500 mm Airway s in mm						
	40	50	60	70	80	90	100
63	9	8	8	7	7	6	6
125	21	20	19	17	16	15	14
250	47	43	39	34	29	26	23
500	50	47	44	39	35	32	30
1 k	50	50	50	50	48	46	44
2 k	50	50	50	50	47	43	40
4 k	50	50	46	39	34	30	26
8 k	50	43	39	32	26	22	19

$f_m$ in Hz	Length L = 3000 mm Airway s in mm						
	40	50	60	70	80	90	100
63	10	9	9	8	8	7	7
125	24	22	21	19	18	17	16
250	50	50	47	40	35	31	28
500	50	50	50	46	42	38	35
1 k	50	50	50	50	50	50	50
2 k	50	50	50	50	50	50	47
4 k	50	50	50	45	39	34	30
8 k	50	50	46	37	30	25	21

# Insertion Loss MSA200

## Identification of the sound attenuator

The determination of, inter alia, the required attenuation, permissible pressure loss and air-regenerated noise, dimensions with respect to an attenuator to be used in an air-conditioning and ventilation system (e.g., according to VDI 2081) is an engineering task which must be performed by the customer.

The relevant calculated requirements to be placed on the sound attenuator are used to make the optimal choice – in particular, with respect to the price.

For this purpose, TROX provides technical data sheets or specific software for personal computers as appropriate and well-proven selection tools; the appropriate application of these is the responsibility of the user.

Insertion loss  $D_{e,oct.}$  in dB

$f_m$ in Hz	Length L = 500 mm Airway s in mm								$f_m$ in Hz	Length L = 1000 mm Airway s in mm							
	60	80	100	120	140	160	180	200		60	80	100	120	140	160	180	200
63	4	3	2	2	1	1	1	1	63	5	4	4	3	3	2	2	2
125	6	5	4	4	3	3	3	3	125	14	11	10	9	8	7	7	7
250	16	13	12	10	9	8	7	7	250	28	24	22	19	16	15	14	12
500	18	14	12	10	9	8	7	6	500	33	27	23	19	17	15	13	12
1 k	22	17	15	12	10	9	8	7	1 k	36	29	26	21	18	16	14	12
2 k	18	13	11	9	8	7	7	6	2 k	32	24	19	16	14	12	10	9
4 k	14	11	9	8	7	6	5	5	4 k	21	16	13	11	10	9	8	8
8 k	12	9	8	7	6	5	4	4	8 k	16	13	11	9	8	7	7	6

$f_m$ in Hz	Length L = 1500 mm Airway s in mm								$f_m$ in Hz	Length L = 2000 mm Airway s in mm							
	60	80	100	120	140	160	180	200		60	80	100	120	140	160	180	200
63	7	6	5	4	4	3	3	3	63	10	8	6	5	5	4	4	4
125	19	16	14	13	11	11	10	9	125	25	21	19	16	15	14	13	12
250	39	34	31	27	24	22	20	18	250	49	44	41	35	31	28	26	24
500	46	38	33	28	24	21	19	17	500	50	49	43	36	31	28	25	23
1 k	49	41	36	29	24	20	17	15	1 k	50	50	46	37	30	25	21	18
2 k	44	32	25	21	18	15	14	12	2 k	50	40	30	25	22	19	17	15
4 k	28	20	16	14	12	11	10	10	4 k	34	24	18	16	14	13	12	11
8 k	21	16	13	11	10	9	8	7	8 k	25	19	16	14	12	10	9	8

$f_m$ in Hz	Length L = 2500 mm Airway s in mm								$f_m$ in Hz	Length L = 3000 mm Airway s in mm							
	60	80	100	120	140	160	180	200		60	80	100	120	140	160	180	200
63	12	10	8	7	6	5	5	5	63	14	12	10	8	7	7	6	6
125	33	28	24	21	19	18	16	15	125	41	34	30	26	24	22	20	19
250	50	50	49	42	38	34	31	29	250	50	50	50	49	44	40	36	34
500	50	50	50	45	39	35	31	28	500	50	50	50	50	46	41	37	34
1 k	50	50	50	45	37	31	26	22	1 k	50	50	50	50	44	37	31	26
2 k	50	47	37	30	25	21	18	16	2 k	50	50	43	35	28	24	20	17
4 k	40	29	22	19	17	15	14	13	4 k	45	33	26	22	20	18	16	15
8 k	29	22	18	15	13	12	10	10	8 k	32	24	19	16	14	13	12	11

# Air-regenerated Noise · Pressure Drop MSA100

## Sound power level of air-regenerated noise

All values were measured according to DIN EN ISO 7235 (1995) in the TROX Laboratory.

The data applies to an entry-flow surface  $B \times H = 1 \text{ m}^2$ .

Please refer to table for correction values for different dimensions.

The air-regenerated noise in the airway should be at least 7 dB below the noise level of the plant. Attention should be paid to air-regenerated noise in the ducting (e.g. in bends, at diffusers).

## Pressure drop

All values were measured according to DIN EN ISO 7235 (1995) in the TROX Laboratory.

**Air-regenerated noise MSA100 and MSA200 in duct**

$v_s$ in m/s	$f_{m, \text{oct.}}$ in Hz								$L_w$ in dB(A)
	63	125	250	500	1k	2k	4k	8k	
4	30	26	22	19	15	12	9	6	21
6	41	36	32	28	25	21	18	15	31
8	48	43	39	35	31	28	25	22	38
10	53	49	44	40	37	33	30	27	43
12	58	53	49	45	41	37	34	31	47
14	62	57	53	49	45	41	38	35	51
16	65	61	56	52	48	44	41	38	54
18	68	64	59	55	51	48	44	41	57
20	71	66	62	57	53	49	46	43	60

**Correction  $L_s$  in dB**

$B \times H$ in $\text{m}^2$	0.1	0.2	0.4	0.8	1.0	2.0	4.0	8.0	10.0
Corr. $L_s$ in dB	-10	-7	-4	-1	±0	+3	+6	+9	+10

**Total pressure drop  $\Delta p$  in Pa, MSA100**

$v_s$ in m/s	Length L = 500 mm Airway s in mm						
	40	50	60	70	80	90	100
4	5	5	4	4	4	4	4
6	12	11	10	9	9	9	8
8	21	19	17	17	16	15	15
10	33	30	27	26	25	24	23
12	48	43	39	37	36	35	34
14	65	58	53	51	49	47	46
16	85	76	70	66	64	62	60
18	108	96	88	84	80	78	76
20	134	118	109	103	99	96	94

$v_s$ in m/s	Length L = 1000 mm Airway s in mm						
	40	50	60	70	80	90	100
4	7	6	5	5	5	4	4
6	16	14	12	11	10	10	10
8	29	24	22	20	19	18	17
10	46	38	34	31	29	28	27
12	66	55	49	45	42	40	38
14	89	75	66	61	57	54	52
16	117	98	87	80	75	71	68
18	148	124	110	101	94	90	87
20	182	153	135	124	117	111	107

$v_s$ in m/s	Length L = 1500 mm Airway s in mm						
	40	50	60	70	80	90	100
4	9	7	6	6	5	5	5
6	21	17	15	13	12	11	11
8	37	30	26	23	21	20	19
10	58	47	40	36	33	31	30
12	83	67	58	52	48	45	43
14	113	92	79	71	66	62	59
16	148	120	103	93	86	81	77
18	187	151	131	118	109	102	97
20	231	187	162	145	134	126	120

$v_s$ in m/s	Length L = 2000 mm Airway s in mm						
	40	50	60	70	80	90	100
4	11	9	8	7	6	6	5
6	25	20	17	15	14	13	12
8	45	35	30	27	24	23	21
10	70	55	47	42	38	35	33
12	101	80	68	60	54	51	48
14	137	108	92	81	74	69	65
16	179	142	120	106	97	90	85
18	226	179	152	135	123	114	107
20	279	221	188	166	151	141	133

$v_s$ in m/s	Length L = 2500 mm Airway s in mm						
	40	50	60	70	80	90	100
4	13	10	9	7	7	6	6
6	30	23	19	17	15	14	13
8	52	41	34	30	27	25	23
10	82	64	53	47	42	39	36
12	118	92	77	67	61	56	52
14	161	125	105	92	83	76	71
16	210	164	137	120	108	100	93
18	266	207	173	152	137	126	118
20	328	256	214	187	169	156	146

$v_s$ in m/s	Length L = 3000 mm Airway s in mm						
	40	50	60	70	80	90	100
4	15	12	10	8	7	7	6
6	34	26	22	19	17	15	14
8	60	46	38	33	30	27	25
10	94	73	60	52	47	43	40
12	136	104	86	75	67	61	57
14	185	142	118	102	91	83	78
16	241	186	154	133	119	109	101
18	305	235	194	168	151	138	128
20	377	290	240	208	186	170	158

# Pressure Drop MSA200

## Example

Given:

Fan data:

$$\dot{V} = 10000 \text{ m}^3/\text{h}$$

$$\Delta p_t = 1000 \text{ Pa}$$

$$n = 1500 \text{ min}^{-1}$$

$$z = 16$$

Design: radial, backwards curved blades; maximum permissible sound power level in duct after sound attenuator: 65 dB(A)

$f_{m, \text{oct}}$ in Hz	63	125	250	500	1k	2k	4k	8k
Fan sound power level (calculated according to VDI 2081)	93	91	89	86	82	77	71	64
Max. perm. octave sound power level at SD outlet (VDI 2081)	86	76	69	63	60	59	59	61
Required insertion loss	7	15	20	23	22	18	12	3
Insertion loss MSA200-80-4 B x H x L = 1120 x 900 x 2000 mm	8	21	44	49	50	40	24	19
Sound power level after attenuator without air-regenerated noise	85	70	45	37	32	37	47	45
Air-regenerated noise attenuator	53	49	44	40	37	33	30	27
Sound power level after attenuator with air-regenerated noise	85	70	47	42	38	37	47	45
A-weighting	-26	-16	-9	-3	± 0	+ 1	+ 1	- 1
Octave sound power level (A-weighted) after attenuator in duct	59	54	38	39	38	38	48	44
Sound power level in dB(A) in duct	61 → Requirement is met							

## Total pressure drop $\Delta p$ in Pa, MSA200

$v_s$ in m/s	Length L = 500 mm Airway s in mm							
	60	80	100	120	140	160	180	200
4	8	6	5	4	4	4	3	3
6	18	14	11	10	9	8	7	7
8	31	24	20	17	15	14	13	12
10	49	38	31	27	24	22	20	19
12	71	55	45	39	35	32	29	27
14	96	74	61	53	47	43	40	37
16	126	97	80	69	62	56	52	48
18	159	123	101	88	78	71	65	61
20	197	151	125	108	96	88	81	75

$v_s$ in m/s	Length L = 1000 mm Airway s in mm							
	60	80	100	120	140	160	180	200
4	9	7	6	5	4	4	4	3
6	20	16	13	11	10	9	8	8
8	36	28	23	20	18	16	15	14
10	57	44	36	31	28	25	23	22
12	82	63	52	45	40	36	33	31
14	111	85	71	61	54	49	45	42
16	145	112	92	80	71	64	59	55
18	183	141	117	101	89	81	75	70
20	226	174	144	124	110	100	92	86

$v_s$ in m/s	Length L = 1500 mm Airway s in mm							
	60	80	100	120	140	160	180	200
4	10	8	7	6	5	5	4	4
6	23	18	15	13	11	10	9	9
8	41	32	26	22	20	18	17	16
10	64	49	41	35	31	28	26	24
12	92	71	59	51	45	41	37	35
14	126	97	80	69	61	55	51	48
16	164	126	104	90	80	72	67	62
18	207	160	132	114	101	92	84	79
20	256	197	163	140	125	113	104	97

$v_s$ in m/s	Length L = 2000 mm Airway s in mm							
	60	80	100	120	140	160	180	200
4	11	9	7	6	6	5	5	4
6	26	20	16	14	12	11	10	10
8	46	35	29	25	22	20	19	17
10	71	55	45	39	35	31	29	27
12	103	79	65	56	50	45	42	39
14	140	108	89	77	68	62	57	53
16	183	141	116	100	89	80	74	69
18	231	178	147	127	112	102	94	87
20	286	220	181	156	139	126	116	108

$v_s$ in m/s	Length L = 2500 mm Airway s in mm							
	60	80	100	120	140	160	180	200
4	13	10	8	7	6	6	5	5
6	28	22	18	16	14	12	11	11
8	50	39	32	28	24	22	20	19
10	79	61	50	43	38	35	32	30
12	114	87	72	62	55	50	46	43
14	155	119	98	85	75	68	62	58
16	202	155	128	110	98	89	81	76
18	255	197	162	140	124	112	103	96
20	315	243	200	172	153	138	127	118

$v_s$ in m/s	Length L = 3000 mm Airway s in mm							
	60	80	100	120	140	160	180	200
4	14	11	9	8	7	6	6	5
6	31	24	20	17	15	14	13	12
8	55	42	35	30	27	24	22	21
10	86	66	55	47	42	38	35	32
12	124	96	79	68	60	54	50	47
14	169	130	107	92	82	74	68	63
16	221	170	140	121	107	97	89	83
18	279	215	177	153	135	122	113	105
20	345	266	219	189	167	151	139	129

# Order Details MSA · MKA

## Specification text

**Splitter attenuator** type MSA in hygiene design with integrated energy savings splitters and aerodynamically profiled frame (radius > 15 mm) type MKA; efficient according to the chamber absorption principle; profile parts and control plates made of galvanized steel sheet, framework end for the protection of the splitters filling through glass fibre fabrics against abrasion up to air speeds of 20 m/s. Insertion loss, sound power level of air-regenerated noise as well as pressure drops measured according to DIN EN ISO 7235. Mineral wool with RAL-quality mark RAL-GZ 388, non-combustible according to DIN 4102 A2, biodegradable in the sense of TRGS 905 and of the European Union guideline 97/69/EEC. Volume weight > 30 kg/m<sup>3</sup>. Both the mineral wool and the laminated glass fibre fabric show inert behavior to fungi and/or bacteria growth. The attenuators fulfill the hygiene requirements of the VDI 6022, of DIN 1946 part 2 and part 4 as well as of VDI 3803.

Casing dimensions

Width in mm

Height in mm

Length in mm

Volume flow rate in l/s (m<sup>3</sup>/h)

Insertion loss in dB at  $f_m = 250$  Hz

Max. permissible total pressure drop in Pa

Quantity

Type (acc. to order code; see below)

MSA...-

Manufacturer

TROX

## Specification text

**Energy savings splitters** type MKA in hygiene design with aerodynamically profiled frame (radius > 15 mm); efficient according to the chamber absorption principle; profile parts and control plates made of galvanized steel sheet, framework end for the protection of the splitters filling through glass fibre fabrics against abrasion up to air speeds of 20 m/s. Insertion loss, sound power level of air-regenerated noise as well as pressure drops measured according to DIN EN ISO 7235. Mineral wool with RAL-quality mark RAL-GZ 388, non-combustible according to DIN 4102 A2, biodegradable in the sense of TRGS 905 and of the European Union guideline 97/69/EEC. Volume weight > 30 kg/m<sup>3</sup>. Both the mineral wool and the laminated glass fibre fabric show inert behavior to fungi and/or bacteria growth. The splitters fulfill the hygiene requirements of the VDI 6022, of DIN 1946 part 2 and part 4 as well as of VDI 3803.

Customer's duct dimension

Width in mm

Height in mm

Length in mm

Volume flow rate in l/s (m<sup>3</sup>/h)

Insertion loss in dB at  $f_m = 250$  Hz

Max. permissible total pressure drop in Pa

Quantity

Type (acc. to order code; see below)

MKA...-

Manufacturer

TROX

## Order code for splitter attenuator

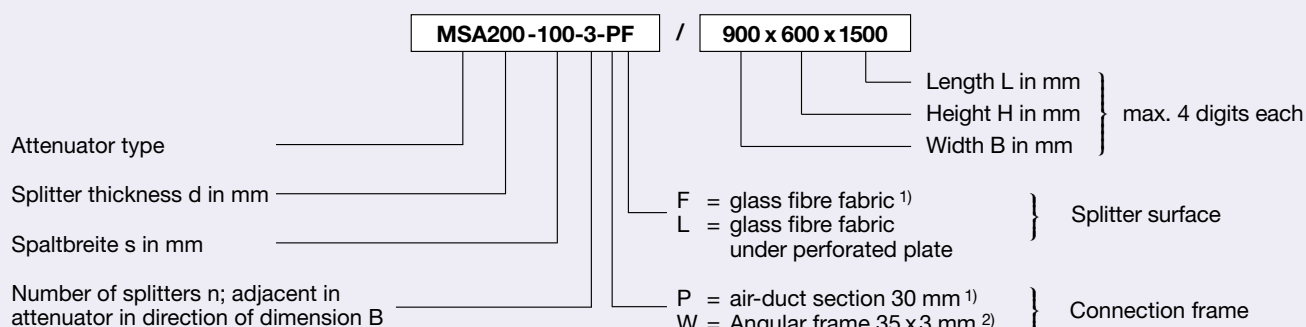

1) Standard Hygiene design

2) Obligatory for attenuators with divided  $B$  and  $H$  dimensions

## Order code for splitters as installation kit

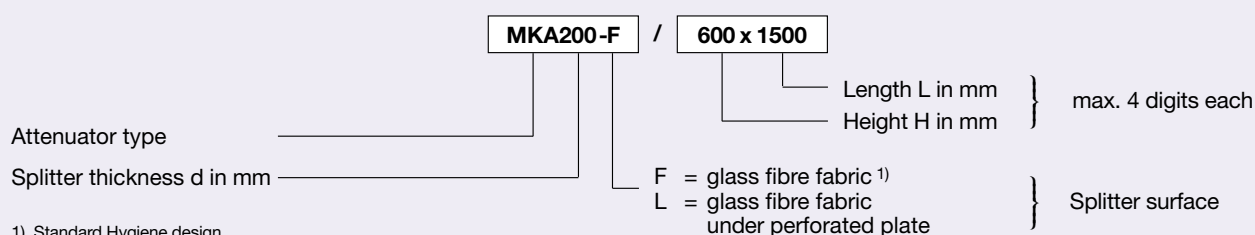

1) Standard Hygiene design

If no entry for splitter surface or connection frame is made in the order, the Standard Hygiene design will be delivered. Design without hygiene certificate on demand.