

# Rectangular Splitter Attenuators

Type XSA200 and XSA300

## Splitters

Type XKA200 and XKA300

Energy-saving splitter hygiene design

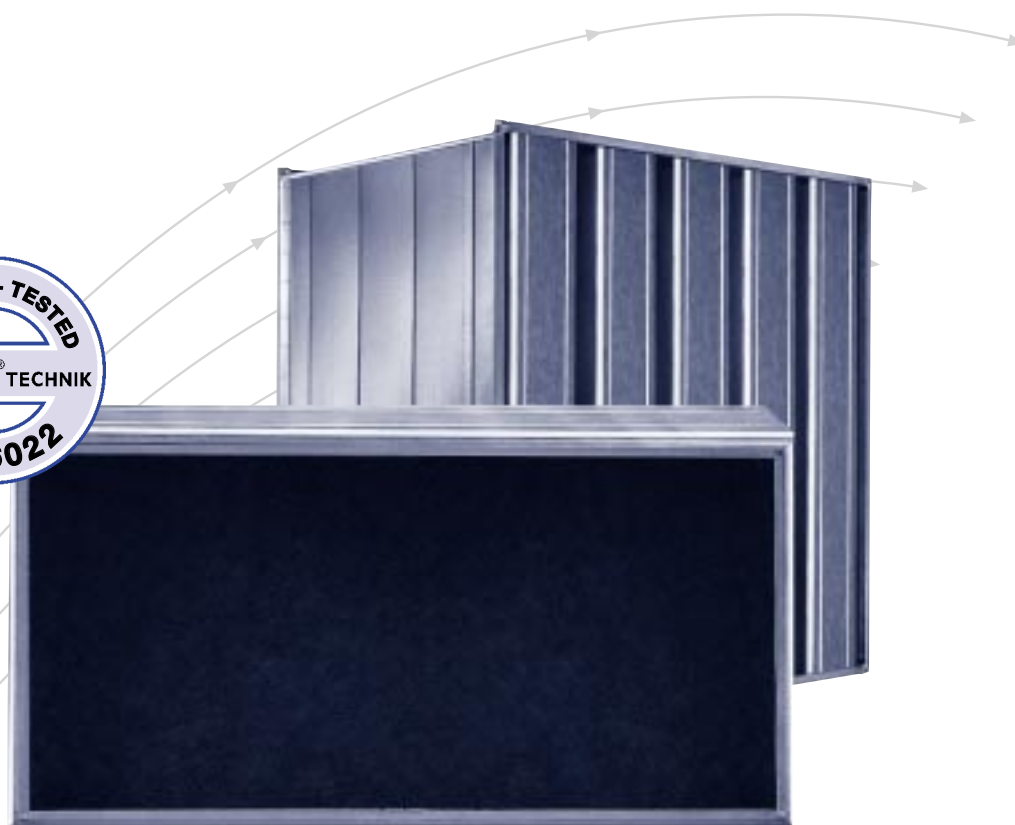

# TROX® TECHNIK

TROX GmbH  
Heinrich-Trox-Platz  
D-47504 Neukirchen-Vluyn

Telephone +49/28 45/2 02-0  
Telefax +49/28 45/2 02-2 65  
e-mail trox@trox.de  
www.troxtechnik.com

# Contents · Description

Description _____	2	Quick selection tables _____	6
Construction · Weight _____	3	Insertion loss _____	8
Construction · Dimensions _____	4	Air-regenerated noise · Pressure drop _____	10
Installation details · Nomenclature · Accessories _____	5	Order details XSA · XKA _____	12

Hygiene design VDI 6022



With the coming into effect of VDI 6022, real hygiene requirements have been placed for the first time on air conditioning and ventilation systems.

The entire air conditioning and ventilation system must consist of materials in the ventilated area which do not emit either health endangering materials or culture mediums for micro organisms. It must be ensured that no source of unhealthy and smelling air components can be loaded in the air.

TROX splitters and splitter attenuators are suitable for use in air conditioning and ventilation systems certified and compliant to VDI 6022 Part 1 and Part 3 as well as to DIN 1946 Part 2 and Part 4 and VDI 3803.

Energy saving by reduced pressure drop

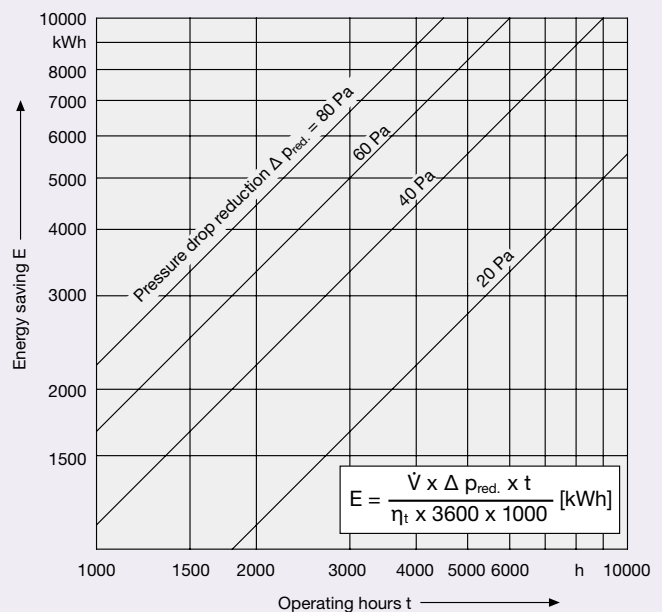

The diagram is based on an overall efficiency  $\eta_t$  of 0.8 of the fan and an air volume flow rate of 80,000 m<sup>3</sup>/h.

The turbulences of the sound attenuator inlet and outlet are reduced by the aerodynamically profiled frame of the splitters. The pressure drop is reduced up to 30 %.

It is thus possible to select smaller gaps and a shorter silencer.

As a result, a more compact design results in direct savings of the operating costs and/or in space saving. When using additional necessary aerodynamic profiles, acoustic and ineffective splitters lengths can be avoided.

The special design causes an increased insertion loss in the area of high frequencies.

## Design versions

The splitters of series X in perforated-plate design differ only slightly from the standard version described here with respect to insertion loss, air-regenerated noise and pressure drop; the data is available in a separate description.

All other design versions (e.g., other splitter thickness) or special versions are supplied without a suitability certificate unless special conditions have been agreed upon.

### Weight XSA200 in kg · Dimensions

Length L in mm	Höhe H in mm	Width B in mm							
		400	800	1200	1600	2000	2400	2400	2400
		with max. number of splitters n							
		1	2	3	4	5	6	7	8
500	300	12	19	26	33	41	48	51	54
	600	16	24	32	41	49	57	61	65
	900	21	31	42	52	62	73	79	85
	1200	26	39	51	63	76	88	96	104
	1500	31	46	60	75	89	103	113	123
1800	38	55	72	90	107	125	138	151	
750	300	15	25	34	44	54	64	68	72
	600	21	33	45	56	68	80	86	92
	900	27	41	55	69	82	96	104	112
	1200	35	51	68	85	102	118	129	140
	1500	41	60	79	97	116	135	148	161
1800	49	72	95	118	140	163	180	197	
1000	300	18	30	42	55	67	79	84	89
	600	27	42	57	72	87	102	110	118
	900	34	51	68	85	102	120	130	140
	1200	42	62	83	103	123	143	156	169
	1500	52	76	100	124	148	172	189	206
1800	61	89	117	145	173	202	223	244	
1250	300	22	36	51	65	80	94	100	106
	600	31	49	66	84	101	119	128	137
	900	41	63	84	106	127	149	162	175
	1200	52	77	103	128	154	179	196	213
	1500	61	90	118	147	175	204	224	244
1800	74	108	143	177	212	246	272	298	
1500	300	25	42	59	76	93	110	117	124
	600	37	57	78	99	120	141	152	163
	900	48	73	98	123	147	172	187	202
	1200	59	88	117	146	175	204	223	242
	1500	71	104	137	169	202	235	258	281
1800	85	125	165	205	245	285	315	345	

Weight incl. perforated-plate cover: + 5 x n x H x L. Weights for lengths over 1500 mm must be added up in the modular dimension.

### Weight XKA200 in kg · Dimensions

Length L in mm	Height H in mm					
	300	600	900	1200	1500	1800
500	3	4	6	8	10	13
750	4	6	8	11	13	17
1000	5	8	10	13	17	21
1250	6	9	13	17	20	26
1500	7	11	15	19	23	30

Weight incl. perforated-plate cover: + 5 x H x L. Weights for lengths and heights outside the table must be added up in the modular dimension.

### Weight XSA300 in kg · Dimensions

Length L in mm	Höhe H in mm	Width B in mm					
		900	1800	2400	2400	2400	2400
		with max. number of splitters n					
		1	2	3	4	5	6
500	300	12	21	29	37	46	54
	600	18	28	38	49	59	69
	900	24	37	51	64	77	91
	1200	29	45	60	75	91	106
	1500	35	54	72	91	109	127
1800	43	65	87	110	132	155	
750	300	16	27	37	48	59	70
	600	24	39	54	68	83	98
	900	31	49	67	85	102	120
	1200	39	59	80	101	122	142
	1500	47	72	97	121	146	171
1800	56	86	116	146	175	205	
1000	300	20	34	48	63	77	91
	600	30	48	66	84	102	120
	900	39	61	83	105	127	150
	1200	48	74	101	127	153	179
	1500	59	90	121	152	183	214
1800	71	109	147	185	223	262	
1250	300	25	42	60	77	95	112
	600	35	57	78	100	121	143
	900	46	73	99	126	152	179
	1200	59	91	124	156	189	221
	1500	70	108	145	183	220	258
1800	85	130	176	221	267	312	
1500	300	28	48	68	88	108	128
	600	42	67	93	119	145	171
	900	55	87	119	151	182	214
	1200	68	106	144	182	220	258
	1500	82	126	170	213	257	301
1800	99	153	207	261	315	369	

Weight incl. perforated-plate cover: + 5 x n x H x L. Weights for lengths over 1500 mm must be added up in the modular dimension.

### Weight XKA300 in kg · Dimensions

Length L in mm	Height H in mm					
	300	600	900	1200	1500	1800
500	4	6	9	11	14	18
750	5	9	12	15	19	24
1000	7	11	15	19	24	31
1250	9	13	18	24	29	37
1500	10	16	22	28	34	44

Weight incl. perforated-plate cover: + 5 x H x L. Weights for lengths and heights outside the table must be added up in the modular dimension.

# Construction · Dimensions

## Splitters

- Aerodynamically shaped frame of galvanised sheet steel, stiffened by crimping.
- Absorption material (highly bio-degradable, no health risk) with laminated non-woven glass fibre fabric to provide protection against abrasion at air velocities of up to 20 m/s; rot-proof and moisture-repellent impregnation, non-flammable according to DIN 4102 A2.
- Operating temperature to 100 °C.
- Can be installed in any position up to and including a height of 1200 mm.
- Fulfills the hygiene requirements of VDI 6022, DIN 1946 part 2 and part 4 as well as of VDI 3803.

## Casing

- Folded casing of galvanised sheet steel stiffened by crimping; larger dimensions additionally with reinforcing strip.
- Connection frame air duct section (30 mm); alternatively, a frame perforated at the factory of galvanised angular steel 35 by 5 mm available. (Please indicate this in the order). In the case of division of the B dimension and/or H dimension, the sound attenuators are delivered with a connection frame of galvanised angular steel as a standard.

Available maximum undivided size B = 2400 mm, H = 1800 mm, L = 1500 mm.

Standard height-modular dimension for splitter and casing: 100 mm.

Splitter XKA...

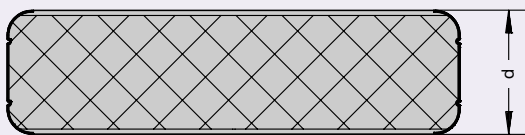
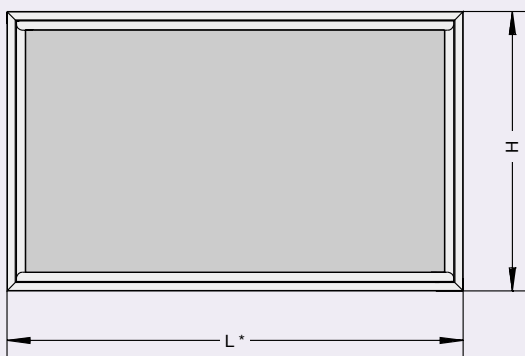

Splitter attenuator XSA...

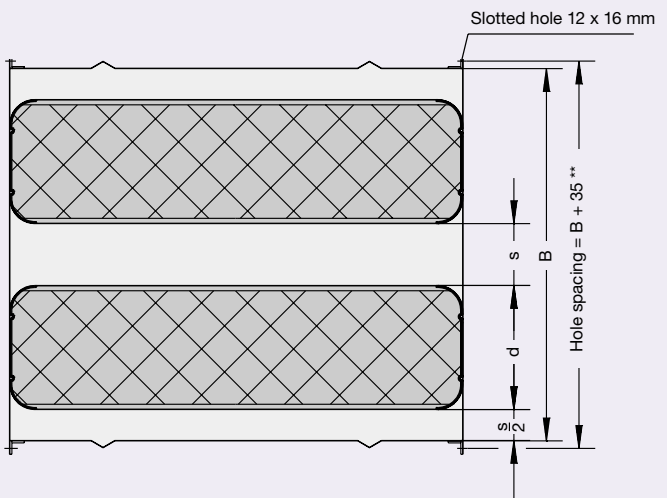
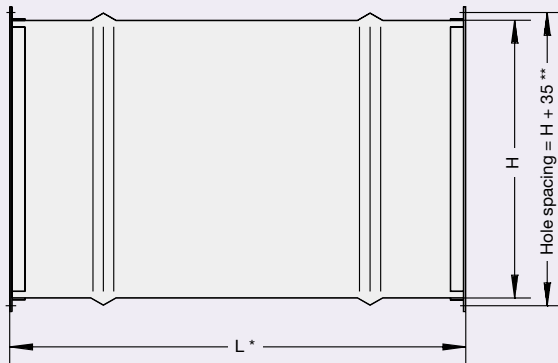

\* The direction of the L dimension is always the same as the direction in which the sound passes. Please remember this with respect to vertical air ducting!

\*\* The spacing and dimension of slotted holes are valid only to connection frames of air duct section (30 mm).

# Installation Details · Nomenclature · Accessories

## Installation details

If splitters are supplied as an installation kit for a sound attenuator or if splitters and attenuator casing are supplied separately, the following paragraph is part of the supply contract:

“The specified performance data is achieved only if the installation details of the manufacturer and the generally accepted rules of engineering are complied with.”

Installation details are specifications, including types and dimensions, in quotations, order confirmations and TROX technical documentation.

## Nomenclature

B	in mm:	Width
H	in mm:	Height
L	in mm:	Length
d	in mm:	Splitter thickness
s	in mm:	Airway width
n	:	Number of adjacent splitters in the B dimension
V	in l/s resp. in m <sup>3</sup> /h:	Volume flow rate
v <sub>s</sub>	in m/s:	Air velocity in the airway
Δp	in Pa:	Total pressure drop
f <sub>m</sub>	in Hz:	Octave centre frequency
D <sub>e</sub>	in dB:	Insertion loss
L <sub>W</sub>	in dB:	Sound power level of the air-regenerated noise in the duct
L <sub>W</sub>	in dB(A):	A-weighted sound pressure level of the air-regenerated noise in the duct
L <sub>S</sub>	in dB:	Correction values for L <sub>W</sub> at B x H ≠ 1 m <sup>3</sup>

## Entry flow condition

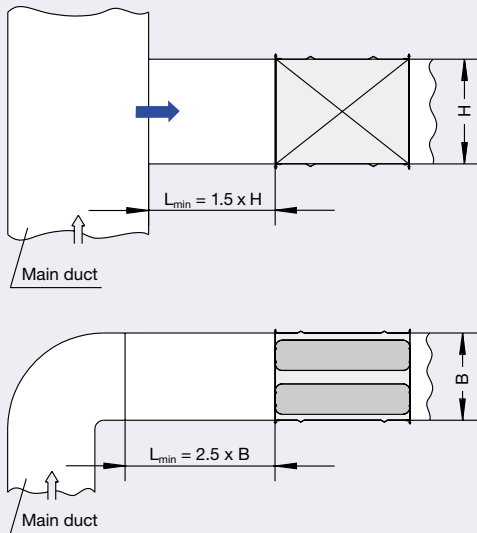

To avoid an overproportional pressure drop, and unstable air-regenerated noise, horizontal installation is recommended (up to heights  $H_{max.} = 1200$  mm possible).

## Max. stacking height (without additional load)

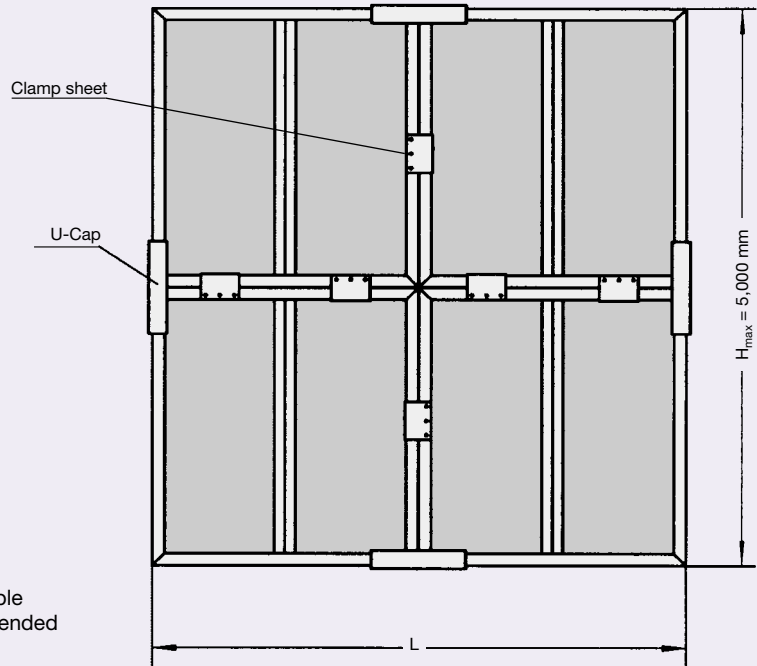

## Accessories

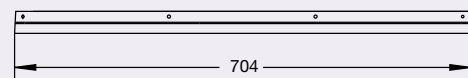
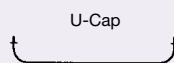
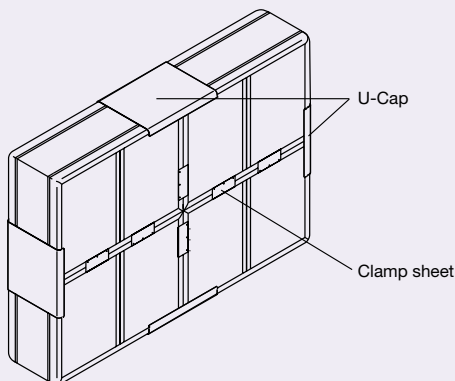

H or L ≤ 750 mm  
without clamp sheet

Clamp sheet

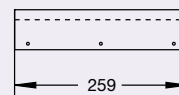

H or L 751 – 1000 mm  
1 clamp sheet on each side

H or L ≥ 1000 mm  
2 clamp sheets recommended

# Quick Selection XSA200 (300... 18,000 l/s)

Volume flow rate $\dot{V}$ at $\Delta p = 50 \text{ Pa}$															
n	Attenuator width B height H* in mm in mm		Insertion loss $D_e$ at 250 Hz in dB												$L_s$ in dB
			9		15		21		28		33		39		
			Attenuator length L in mm				Volume flow rate $\dot{V}$ in								
			500		1000		1500		2000		2500		3000		
		l/s	m <sup>3</sup> /h	l/s	m <sup>3</sup> /h	l/s	m <sup>3</sup> /h	l/s	m <sup>3</sup> /h	l/s	m <sup>3</sup> /h	l/s	m <sup>3</sup> /h	l/s	m <sup>3</sup> /h
1	300	300	376	1354	349	1255	326	1175	308	1109	292	1052	279	1004	- 10
		600	760	2736	710	2555	668	2406	633	2281	604	2173	577	2079	- 7
		900	1144	4118	1071	3856	1011	3639	960	3454	915	3296	877	3157	- 6
2	600	300	752	2707	697	2510	653	2350	616	2217	585	2105	558	2008	- 7
		600	1520	5471	1419	5110	1337	4812	1267	4561	1207	4346	1155	4158	- 4
		900	2288	8235	2142	7712	2022	7277	1919	6909	1831	6591	1754	6314	- 3
		1200	3055	11000	2865	10315	2707	9743	2572	9258	2455	8838	2353	8471	- 1
		1500	3823	13764	3588	12917	3392	12210	3224	11607	3079	11085	2952	10628	± 0
		1800	4591	16529	4311	15520	4077	14676	3877	13956	3704	13333	3552	12786	± 0
3	900	300	1128	4061	1046	3765	979	3525	924	3326	877	3157	836	3011	- 6
		600	2280	8207	2129	7665	2005	7218	1900	6842	1811	6518	1732	6237	- 3
		900	3431	12353	3213	11568	3032	10916	2879	10363	2746	9887	2631	9470	- 1
		1200	4583	16499	4298	15472	4060	14615	3857	13887	3683	13257	3529	12706	± 0
		1500	5735	20646	5382	19376	5087	18314	4836	17410	4619	16628	4429	15943	+ 1
		1800	6887	24793	6467	23280	6115	22014	5815	20934	5555	20000	5328	19180	+ 2
4	1200	300	1504	5415	1394	5019	1305	4700	1232	4434	1169	4209	1115	4015	- 4
		600	3039	10942	2839	10220	2673	9625	2534	9122	2414	8691	2310	8316	- 1
		900	4575	16471	4285	15424	4043	14555	3838	13818	3662	13182	3508	12627	± 0
		1200	6111	21999	5730	20629	5413	19487	5143	18515	4910	17676	4706	16941	+ 2
		1500	7647	27528	7176	25834	6783	24419	6448	23214	6159	22171	5905	21257	+ 3
		1800	9183	33057	8622	31040	8153	29352	7753	27913	7407	26666	7104	25573	+ 3
5	1500	300	1880	6768	1743	6274	1632	5875	1540	5543	1461	5261	1394	5019	- 3
		600	3799	13678	3549	12775	3342	12031	3167	11403	3018	10864	2887	10395	± 0
		900	5719	20588	5356	19280	5054	18194	4798	17272	4577	16478	4384	15784	+ 1
		1200	7639	27499	7163	25786	6766	24359	6429	23144	6138	22095	5882	21177	+ 3
		1500	9558	34410	8970	32293	8479	30524	8060	29017	7698	27713	7381	26571	+ 4
		1800	11478	41321	10778	38800	10192	36690	9692	34891	9259	33333	8879	31966	+ 4
6	1800	300	2256	8122	2091	7529	1958	7049	1848	6651	1754	6314	1673	6023	- 3
		600	4559	16413	4258	15330	4010	14437	3801	13683	3621	13037	3465	12474	± 0
		900	6863	24706	6427	23136	6065	21832	5757	20727	5493	19774	5261	18941	+ 2
		1200	9166	32999	8595	30944	8120	29230	7715	27773	7365	26514	7059	25412	+ 3
		1500	11470	41292	10764	38752	10175	36629	9672	34821	9238	33256	8857	31885	+ 4
		1800	13774	49586	12933	46560	12230	44028	11630	41869	11111	39999	10655	38359	+ 5
7	2100	300	2632	9476	2440	8784	2285	8224	2155	7760	2046	7366	1952	7027	- 2
		600	5319	19149	4968	17885	4679	16843	4434	15964	4225	15210	4042	14553	+ 1
		900	8006	28823	7498	26992	7075	25471	6717	24181	6408	23069	6138	22098	+ 3
		1200	10694	38499	10028	36101	9473	34102	9001	32402	8593	30933	8235	29648	+ 4
		1500	13382	48174	12558	45210	11870	42734	11284	40624	10777	38799	10333	37199	+ 5
		1800	16069	57850	15089	54320	14268	51366	13569	48847	12963	46666	12431	44752	+ 6
8	2400	300	3008	10829	2789	10039	2611	9399	2463	8868	2338	8418	2231	8030	- 1
		600	6079	21884	5678	20440	5347	19249	5068	18245	4828	17382	4620	16632	+ 2
		900	9150	32941	8569	30848	8086	29110	7677	27636	7324	26365	7015	25255	+ 3
		1200	12222	43999	11461	41258	10826	38974	10286	37031	9820	35352	9412	33883	+ 5
		1500	15293	55056	14352	51669	13566	48839	12897	46427	12317	44342	11809	42514	+ 6
		1800	18365	66114	17244	62080	16307	58704	15507	55825	14814	53332	14207	51146	+ 6
$L_w$		49		47		46		44		43		43		in dB(A)	
$v_s$ (approx.)		12.8		12.0		11.3		10.8		10.3		9.9		in m/s	

\* Standard-height-module dimension: 100 mm

# Quick Selection XSA300 (500 ... 16,500 l/s)

## Quick selection table XSA300

The volume flow rates specified in the table apply to a pressure drop of approx. 50 Pa.

$L_w$  is the A-weighted sound power level of the air-regenerated noise in the duct at the attenuator outlet level, applicable to  $B \times H = 1 \text{ m}^2$ .

For other surface areas, the value must be corrected with  $L_s$ .

Volume flow rate $\dot{V}$ at $\Delta p = 50 \text{ Pa}$															
n	Attenuator width B in mm, height H* in mm		Insertion loss $D_o$ at 250 Hz in dB												$L_s$ in dB
			11		18		25		32		39		47		
			Attenuator length L in mm												
			500		1000		1500		2000		2500		3000		
Volume flow rate $\dot{V}$ in															
		l/s	m <sup>3</sup> /h	l/s	m <sup>3</sup> /h	l/s	m <sup>3</sup> /h	l/s	m <sup>3</sup> /h	l/s	m <sup>3</sup> /h	l/s	m <sup>3</sup> /h	l/s	m <sup>3</sup> /h
1	450	300	553	1989	545	1960	537	1933	530	1906	522	1881	516	1856	-9
		600	1108	3988	1094	3940	1081	3893	1069	3848	1057	3804	1045	3762	-6
		900	1663	5987	1644	5919	1626	5853	1608	5789	1591	5727	1574	5668	-4
2	900	300	1105	3978	1089	3921	1074	3865	1059	3812	1045	3762	1031	3713	-6
		600	2216	7977	2189	7879	2163	7786	2138	7695	2113	7608	2090	7523	-3
		900	3326	11975	3288	11838	3252	11706	3216	11578	3182	11455	3149	11335	-1
		1200	4435	15966	4385	15784	4336	15608	4288	15438	4243	15273	4198	15113	± 0
		1500	5548	19971	5488	19756	5430	19548	5374	19345	5319	19150	5267	18960	+1
		1800	6658	23970	6587	23715	6519	23468	6453	23229	6388	22997	6326	22772	+2
3	1350	300	1658	5968	1634	5881	1611	5798	1589	5719	1567	5642	1547	5569	-4
		600	3324	11965	3283	11819	3244	11678	3206	11543	3170	11412	3135	11285	-1
		900	4990	17962	4933	17757	4878	17559	4824	17368	4773	17182	4723	17003	+1
		1200	6653	23950	6577	23676	6503	23412	6432	23157	6364	22910	6297	22670	+2
		1500	8321	29957	8232	29634	8145	29321	8061	29018	7979	28724	7900	28439	+3
		1800	9987	35954	9881	35572	9778	35202	9679	34844	9582	34496	9488	34158	+4
4	1800	300	2210	7957	2178	7841	2147	7731	2118	7625	2090	7523	2063	7426	-3
		600	4431	15953	4377	15759	4325	15571	4275	15390	4227	15216	4180	15047	± 0
		900	6653	23950	6577	23676	6503	23412	6432	23157	6364	22910	6297	22670	+2
		1200	8870	31933	8769	31569	8671	31217	8577	30876	8485	30546	8396	30227	+3
		1500	11095	39943	10976	39512	10860	39095	10747	38691	10639	38299	10533	37919	+4
		1800	13316	47939	13175	47430	13038	46936	12905	46458	12776	45994	12651	45544	+5
5	2250	300	2763	9946	2723	9802	2684	9664	2648	9531	2612	9404	2578	9282	-2
		600	5539	19942	5472	19698	5407	19464	5344	19238	5283	19019	5224	18808	+1
		900	8316	29937	8221	29596	8129	29265	8041	28946	7955	28637	7872	28338	+3
		1200	11088	39916	10961	39461	10839	39021	10721	38595	10606	38183	10495	37784	+4
		1500	13869	49928	13719	49390	13575	48869	13434	48364	13298	47874	13166	47399	+5
		1800	16646	59924	16469	59287	16297	58671	16131	58073	15970	57493	15814	56930	+6
$L_w$		47		47		47		46		46		46		in dB(A)	
$v_s$ (approx.)		12.3		12.2		12.1		11.9		11.8		11.7		in m/s	

\* Standard-height-module dimension: 100 mm

# Insertion Loss XSA200

## Insertion loss $D_e$

All values were measured according to DIN EN ISO 7235 (1995) in the TROX Laboratory.

Linear interpolation between specified values is permitted.

## Test method

The Duct Reverberation Chamber Method was chosen from the test methods described in DIN EN ISO 7235.

In accordance with this method, a noise is applied to an empty duct the third octave level of which is measured in a connected reverberation chamber under defined conditions.

The attenuator to be tested is then inserted in the empty duct and the measurement is repeated. The difference between the two measurements is the "insertion loss  $D_e$ ".

On the basis of the measured values of the third octave, the measured octave values are then calculated.

Measured laboratory values above 50 dB are specified as 50 dB according to general practice.

The measurement with simultaneously flowing air as also defined in DIN EN ISO 7235 does not have to be performed with respect to sound attenuators used in air-conditioning and ventilation systems since the influence on the measured values is within the usual tolerances.

The acoustic measurements were carried out according to DIN EN 23741 (1991).

Insertion loss  $D_{e, \text{oct}}$  in dB

$f_m$ in Hz	Length L = 500 mm Airway s in mm							
	60	80	100	120	140	160	180	200
63	2	3	3	2	2	2	2	2
125	9	6	4	3	3	3	3	2
250	15	11	9	8	7	7	6	6
500	27	22	19	17	15	14	13	12
1 k	37	30	25	22	19	17	15	14
2 k	35	27	22	18	15	13	12	11
4 k	24	19	16	13	11	9	8	7
8 k	18	14	11	9	8	7	6	5

$f_m$ in Hz	Length L = 1000 mm Airway s in mm							
	60	80	100	120	140	160	180	200
63	5	4	3	3	3	2	2	2
125	12	9	8	7	6	6	5	5
250	19	16	15	13	12	12	11	11
500	39	34	31	28	26	24	23	22
1 k	50	49	45	38	33	30	27	24
2 k	50	42	37	31	26	23	20	18
4 k	31	26	23	19	16	14	12	11
8 k	23	18	16	13	11	9	8	7

$f_m$ in Hz	Length L = 1500 mm Airway s in mm							
	60	80	100	120	140	160	180	200
63	7	6	5	4	4	3	3	3
125	17	14	12	10	9	8	7	7
250	27	24	21	19	18	17	16	15
500	50	48	46	41	37	35	32	31
1 k	50	50	50	50	45	41	37	34
2 k	50	50	50	43	36	31	27	24
4 k	42	35	31	25	21	18	15	14
8 k	28	23	20	16	13	11	10	8

$f_m$ in Hz	Length L = 2000 mm Airway s in mm							
	60	80	100	120	140	160	180	200
63	9	7	6	5	5	4	4	4
125	23	18	16	13	12	11	10	9
250	35	31	28	25	23	22	21	20
500	50	50	50	50	49	45	42	40
1 k	50	50	50	50	50	50	47	44
2 k	50	50	50	50	45	39	34	30
4 k	50	44	39	31	26	22	19	16
8 k	33	27	24	19	16	13	11	10

$f_m$ in Hz	Length L = 2500 mm Airway s in mm							
	60	80	100	120	140	160	180	200
63	11	9	7	6	6	5	5	4
125	29	24	20	17	15	13	12	11
250	42	37	33	30	27	26	24	23
500	50	50	50	50	50	50	50	49
1 k	50	50	50	50	50	50	50	50
2 k	50	50	50	50	50	45	40	35
4 k	50	50	44	36	30	25	22	19
8 k	38	31	27	21	18	15	13	11

$f_m$ in Hz	Length L = 3000 mm Airway s in mm							
	60	80	100	120	140	160	180	200
63	13	10	8	7	6	6	5	5
125	36	29	25	21	18	16	15	13
250	49	42	39	35	32	29	28	26
500	50	50	50	50	50	50	50	50
1 k	50	50	50	50	50	50	50	50
2 k	50	50	50	50	50	50	46	41
4 k	50	50	50	40	33	28	24	21
8 k	44	35	30	24	20	17	14	12

# Insertion Loss XSA300

## Identification of the sound attenuator

The determination of, inter alia, the required attenuation, permissible pressure loss and air-regenerated noise, dimensions with respect to an attenuator to be used in an air-conditioning and ventilation system (e.g., according to VDI 2081) is an engineering task which must be performed by the customer.

The relevant calculated requirements to be placed on the sound attenuator are used to make the optimal choice – in particular, with respect to the price.

For this purpose, TROX provides technical data sheets or specific software for personal computers as appropriate and well-proven selection tools; the appropriate application of these is the responsibility of the user.

Insertion loss  $D_{e,oct.}$  in dB

$f_m$ in Hz	Length L = 500 mm Airway s in mm								$f_m$ in Hz	Length L = 1000 mm Airway s in mm							
	100	150	200	250	300	400	500	600		100	150	200	250	300	400	500	600
63	3	2	1	1	1	1	0	0	63	4	3	2	2	2	1	1	1
125	6	5	4	3	3	2	2	2	125	12	9	7	6	6	5	4	4
250	14	11	9	8	7	5	4	4	250	21	18	15	13	12	10	8	7
500	20	16	13	11	9	7	6	5	500	34	27	21	18	16	12	10	8
1 k	26	19	14	12	10	7	6	5	1 k	40	33	25	19	16	11	9	7
2 k	24	17	12	9	7	6	5	5	2 k	39	28	19	14	11	8	6	5
4 k	17	12	9	7	6	4	3	3	4 k	24	17	12	9	7	6	4	4
8 k	13	9	7	6	5	4	4	4	8 k	18	11	8	6	5	5	5	5

$f_m$ in Hz	Length L = 1500 mm Airway s in mm								$f_m$ in Hz	Length L = 2000 mm Airway s in mm							
	100	150	200	250	300	400	500	600		100	150	200	250	300	400	500	600
63	6	3	3	3	2	2	1	1	63	7	4	4	3	3	2	1	1
125	17	14	11	9	8	7	6	6	125	21	18	15	12	11	9	8	7
250	29	25	21	19	18	14	12	10	250	37	32	28	25	23	18	16	14
500	43	37	30	25	22	17	14	12	500	50	47	38	32	28	22	18	15
1 k	50	45	34	27	23	16	11	9	1 k	50	50	43	35	29	20	14	11
2 k	48	38	26	19	14	10	7	6	2 k	50	49	33	23	17	12	9	7
4 k	32	21	15	11	9	6	5	4	4 k	39	25	18	13	10	7	6	5
8 k	21	13	9	7	6	5	5	5	8 k	24	15	11	8	6	6	5	5

$f_m$ in Hz	Length L = 2500 mm Airway s in mm								$f_m$ in Hz	Length L = 3000 mm Airway s in mm							
	100	150	200	250	300	400	500	600		100	150	200	250	300	400	500	600
63	9	5	4	4	4	3	2	1	63	10	6	5	5	4	3	2	2
125	26	23	18	15	14	11	10	9	125	31	27	22	18	16	13	12	11
250	45	39	34	31	28	23	19	17	250	50	47	40	36	34	27	23	20
500	50	50	46	39	34	27	22	19	500	50	50	50	46	41	31	26	22
1 k	50	50	50	42	36	24	17	12	1 k	50	50	50	50	42	28	20	14
2 k	50	50	40	28	20	14	10	7	2 k	50	50	47	32	23	15	11	8
4 k	47	30	20	15	11	8	6	5	4 k	50	34	23	17	13	9	7	5
8 k	27	18	12	8	6	6	6	6	8 k	31	20	13	9	7	6	6	6

# Air-regenerated Noise · Pressure Drop XSA200

## Sound power level of air-regenerated noise

All values were measured according to DIN EN ISO 7235 (1995) in the TROX Laboratory.

The data applies to an entry-flow surface  $B \times H = 1 \text{ m}^2$ .

Please refer to table for correction values for different dimensions.

The air-regenerated noise in the airway should be at least 7 dB below the noise level of the plant. Attention should be paid to air-regenerated noise in the ductings (e.g. in bends, at diffusers).

## Pressure drop

All values were measured according to DIN EN ISO 7235 (1995) in the TROX Laboratory.

## Air-regenerated noise XSA200 and XSA300 in duct

$v_s$ in m/s	$f_{m, oct.}$ in Hz								$L_w$ in dB(A)
	63	125	250	500	1k	2k	4k	8k	
4	30	26	22	19	15	12	9	6	21
6	41	36	32	28	25	21	18	15	31
8	48	43	39	35	31	28	25	22	38
10	53	49	44	40	37	33	30	27	43
12	58	53	49	45	41	37	34	31	47
14	62	57	53	49	45	41	38	35	51
16	65	61	56	52	48	44	41	38	54
18	68	64	59	55	51	48	44	41	57
20	71	66	62	57	53	49	46	43	60

## Correction $L_s$ in dB

$B \times H$ in $\text{m}^2$	0.1	0.2	0.4	0.8	1.0	2.0	4.0	8.0	10.0
Corr. $L_s$ in dB	-10	-7	-4	-1	±0	+3	+6	+9	+10

## Total pressure drop $\Delta p$ in Pa, XSA200

$v_s$ in m/s	Length L = 500 mm Airway s in mm							
	60	80	100	120	140	160	180	200
4	8	6	5	4	4	4	3	3
6	18	14	11	10	9	8	7	7
8	31	24	20	17	15	14	13	12
10	49	38	31	27	24	22	20	19
12	71	55	45	39	35	32	29	27
14	96	74	61	53	47	43	40	37
16	126	97	80	69	62	56	52	48
18	159	123	101	88	78	71	65	61
20	197	151	125	108	96	88	81	75

$v_s$ in m/s	Length L = 1000 mm Airway s in mm							
	60	80	100	120	140	160	180	200
4	9	7	6	5	4	4	4	3
6	20	16	13	11	10	9	8	8
8	36	28	23	20	18	16	15	14
10	57	44	36	31	28	25	23	22
12	82	63	52	45	40	36	33	31
14	111	85	71	61	54	49	45	42
16	145	112	92	80	71	64	59	55
18	183	141	117	101	89	81	75	70
20	226	174	144	124	110	100	92	86

$v_s$ in m/s	Length L = 1500 mm Airway s in mm							
	60	80	100	120	140	160	180	200
4	10	8	7	6	5	5	4	4
6	23	18	15	13	11	10	9	9
8	41	32	26	22	20	18	17	16
10	64	49	41	35	31	28	26	24
12	92	71	59	51	45	41	37	35
14	126	97	80	69	61	55	51	48
16	164	126	104	90	80	72	67	62
18	207	160	132	114	101	92	84	79
20	256	197	163	140	125	113	104	97

$v_s$ in m/s	Length L = 2000 mm Airway s in mm							
	60	80	100	120	140	160	180	200
4	11	9	7	6	6	5	5	4
6	26	20	16	14	12	11	10	10
8	46	35	29	25	22	20	19	17
10	71	55	45	39	35	31	29	27
12	103	79	65	56	50	45	42	39
14	140	108	89	77	68	62	57	53
16	183	141	116	100	89	80	74	69
18	231	178	147	127	112	102	94	87
20	286	220	181	156	139	126	116	108

$v_s$ in m/s	Length L = 2500 mm Airway s in mm							
	60	80	100	120	140	160	180	200
4	13	10	8	7	6	6	5	5
6	28	22	18	16	14	12	11	11
8	50	39	32	28	24	22	20	19
10	79	61	50	43	38	35	32	30
12	114	87	72	62	55	50	46	43
14	155	119	98	85	75	68	62	58
16	202	155	128	110	98	89	81	76
18	255	197	162	140	124	112	103	96
20	315	243	200	172	153	138	127	118

$v_s$ in m/s	Length L = 3000 mm Airway s in mm							
	60	80	100	120	140	160	180	200
4	14	11	9	8	7	6	6	5
6	31	24	20	17	15	14	13	12
8	55	42	35	30	27	24	22	21
10	86	66	55	47	42	38	35	32
12	124	96	79	68	60	54	50	47
14	169	130	107	92	82	74	68	63
16	221	170	140	121	107	97	89	83
18	279	215	177	153	135	122	113	105
20	345	266	219	189	167	151	139	129

# Pressure Drop XSA300

## Example

Given:

Fan data:

$$\dot{V} = 10000 \text{ m}^3/\text{h}$$

$$\Delta p_t = 1000 \text{ Pa}$$

$$n = 1500 \text{ min}^{-1}$$

$$z = 16$$

Design: radial, backwards curved blades; maximum permissible sound power level in duct after sound attenuator: 65 dB(A)

$f_{m, \text{oct}}$ in Hz	63	125	250	500	1k	2k	4k	8k
Fan sound power level (calculated according to DIN 2081)	93	91	89	86	82	77	71	64
Max. perm. octave sound power level at SD outlet (VDI 2081)	86	76	69	63	60	59	59	61
Required insertion loss	7	15	20	23	22	18	12	3
Insertion loss XSA200-100-3	8	25	39	50	50	50	50	30
B x H x L = 900 x 900 x 3000 mm								
Sound power level after attenuator without air-regenerated noise	85	66	50	36	32	27	21	34
Air-regenerated noise attenuator	53	49	44	40	37	33	30	27
Correction $L_S$ (B x H = 0.81 m <sup>2</sup> )	-1	-1	-1	-1	-1	-1	-1	-1
Sound power level after attenuator with air-regenerated noise	85	66	51	41	37	33	30	35
A-weighting	-26	-16	-9	-3	± 0	+1	+1	-1
Octave sound power level (A-weighted) after attenuator in duct	59	50	42	38	37	34	31	34
Sound power level in dB(A) in duct	60 → Requirement is met							

## Total pressure drop $\Delta p$ in Pa, XSA300

$v_s$ in m/s	Length L = 500 mm Airway s in mm							
	100	150	200	250	300	400	500	600
4	7	5	4	4	4	3	3	3
6	16	12	10	9	8	7	7	6
8	29	21	18	16	14	13	12	11
10	45	33	28	25	23	20	19	18
12	64	48	40	36	33	29	27	25
14	88	65	54	48	44	39	36	34
16	115	85	71	63	58	51	47	45
18	145	107	90	80	73	65	60	57
20	179	132	111	99	91	80	74	70

$v_s$ in m/s	Length L = 1000 mm Airway s in mm							
	100	150	200	250	300	400	500	600
4	8	5	4	4	4	3	3	3
6	17	12	10	9	8	7	7	6
8	31	22	18	16	15	13	12	11
10	48	34	28	25	23	20	19	18
12	69	49	40	36	33	29	27	25
14	94	66	55	48	45	39	36	34
16	123	87	72	63	58	52	48	45
18	156	110	91	80	74	65	60	57
20	192	136	112	99	91	81	74	70

$v_s$ in m/s	Length L = 1500 mm Airway s in mm							
	100	150	200	250	300	400	500	600
4	8	6	5	4	4	3	3	3
6	18	13	10	9	8	7	7	6
8	33	22	18	16	15	13	12	11
10	51	35	28	25	23	20	19	18
12	74	50	41	36	33	29	27	25
14	101	68	56	49	45	40	37	34
16	132	89	73	64	59	52	48	45
18	166	113	92	81	74	65	60	57
20	206	139	114	100	92	81	75	70

$v_s$ in m/s	Length L = 2000 mm Airway s in mm							
	100	150	200	250	300	400	500	600
4	9	6	5	4	4	3	3	3
6	20	13	10	9	8	7	7	6
8	35	23	18	16	15	13	12	11
10	55	36	29	25	23	20	19	18
12	79	51	42	36	33	29	27	25
14	107	70	57	49	45	40	37	34
16	140	91	74	64	59	52	48	45
18	177	115	93	81	75	66	60	57
20	219	142	115	100	92	81	75	70

$v_s$ in m/s	Length L = 2500 mm Airway s in mm							
	100	150	200	250	300	400	500	600
4	9	6	5	4	4	3	3	3
6	21	13	11	9	8	7	7	6
8	37	23	19	16	15	13	12	11
10	58	36	29	25	23	20	19	18
12	84	52	42	36	33	29	27	25
14	114	71	57	49	45	40	37	35
16	148	93	75	64	59	52	48	45
18	188	118	95	81	75	66	61	57
20	232	146	117	100	93	81	75	71

$v_s$ in m/s	Length L = 3000 mm Airway s in mm							
	100	150	200	250	300	400	500	600
4	10	6	5	4	4	3	3	3
6	22	13	11	9	8	7	7	6
8	39	24	19	16	15	13	12	11
10	61	37	30	25	23	20	19	18
12	88	54	43	36	33	29	27	25
14	120	73	58	49	46	40	37	35
16	157	95	76	64	60	52	48	45
18	199	121	96	81	75	66	61	57
20	245	149	118	100	93	82	75	71

# Order Details XSA · XKA

## Specification text

**Splitter attenuator** type XSA in hygiene design with integrated energy savings splitters type XKA and aerodynamically profiled frame (radius > 15 mm); efficient according to the absorption principle; profile parts made of galvanized steel sheet, framework end for the protection of the splitters filling through glass fibre fabrics against abrasion up to air speeds of 20 m/s. Insertion loss, sound power level of air-regenerated noise as well as pressure drops measured according to DIN EN ISO 7235. Mineral wool with RAL-quality mark RAL-GZ 388, non-combustible to DIN 4102 A2, biodegradable in the sense of TRGS 905 and of the European Union guideline 97/69/EEC. Volume weight > 30 kg/m<sup>3</sup>. Both the mineral wool and the laminated glass fibre fabric show inert behavior to fungi and/or bacteria growth. The attenuators fulfill the hygiene requirements of VDI 6022, of DIN 1946 part 2 and part 4 as well as of VDI 3803.

Casing dimensions

Width in mm

Height in mm

Length in mm

Volume flow rate in l/s (m<sup>3</sup>/h)

Insertion loss in dB at  $f_m = 250$  Hz

Max. permissible total pressure drop in Pa

Quantity

Type (acc. to order code; see below)

XSA...-

Manufacturer

TROX

## Specification text

**Energy savings splitters** type XKA in hygiene design with aerodynamically profiled frame (radius > 15 mm); efficient according to the absorption principle; profile parts made of galvanized steel sheet, framework end for the protection of the splitters filling through glass fibre fabrics against abrasion up to air speeds of 20 m/s. Insertion loss, sound power level of air-regenerated noise as well as pressure drops measured according to DIN EN ISO 7235. Mineral wool with RAL-quality mark RAL-GZ 388, non-combustible according to DIN 4102 A2, biodegradable in the sense of TRGS 905 and of the European Union guideline 97/69/EEC. Volume weight > 30 kg/m<sup>3</sup>. Both the mineral wool and the laminated glass fibre fabric show inert behavior to fungi and/or bacteria growth. The splitters fulfill the hygiene requirements of VDI 6022, of DIN 1946 part 2 and part 4 as well as of VDI 3803.

Customer's duct dimension

Width in mm

Height in mm

Length in mm

Volume flow rate in l/s (m<sup>3</sup>/h)

Insertion loss in dB at  $f_m = 250$  Hz

Max. permissible total pressure drop in Pa

Quantity

Type (acc. to order code; see below)

XKA...-

Manufacturer

TROX

## Order code for splitter attenuator

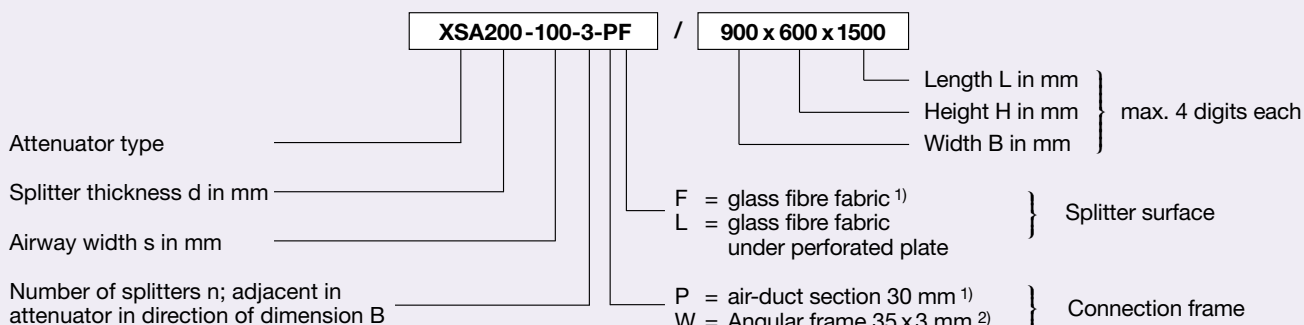

1) Standard Hygiene design

2) Obligatory for attenuators with divided  $B$  and  $H$  dimensions

## Order code for splitters as installation kit

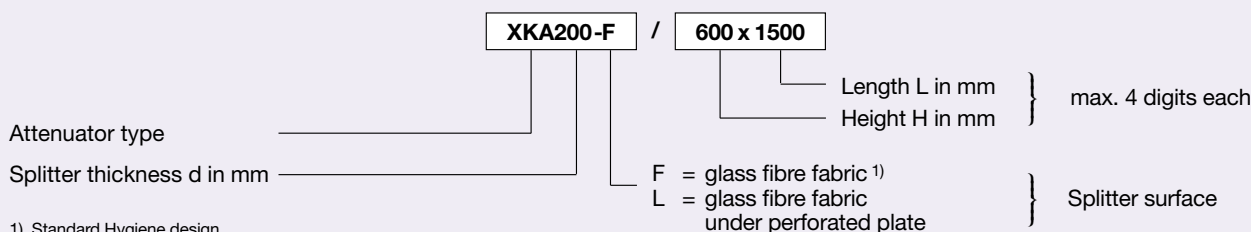

1) Standard Hygiene design

If no entry for splitter surface or connection frame is made in the order, the Standard Hygiene design will be delivered. Design without hygiene certificate on demand.