

# Diffusion grille

Type DGSELF

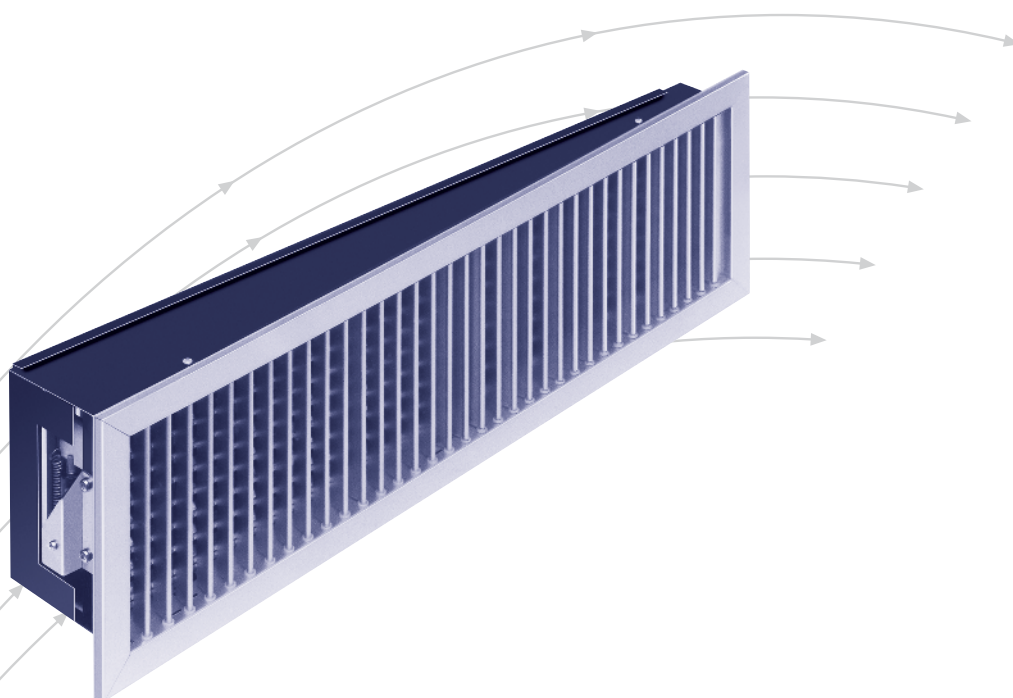

**TROX**® **TECHNIK**



TROX HESCO Schweiz AG  
Walderstrasse 125  
Postfach 455  
CH - 8630 Rüti ZH

Tel. +41 (0)55 250 71 11  
Fax +41 (0)55 250 73 10  
[www.troxhesco.ch](http://www.troxhesco.ch)  
[info@troxhesco.ch](mailto:info@troxhesco.ch)

## Contents

Application · Characteristics	2
Realisation	3
Position of blades	4
Dimensions · Recess	5
Areas of application · Installation examples	6
Order Details	7 - 8

## Application

For energy-saving supply air systems in halls for (e.g. exhibitions, workshops, multi-purposes, warehouses etc.) where, apart from an effective distribution of air and the elimination of thermal stratification, great importance is attached to comfort in the working area at any point within the plant.

## Characteristics

The diffusion grilles DGSELF are supply air outlets, whose horizontal air guide blades are adjusted by a temperature indicator. This results in an automatic temperature-dependent deflection of air streams in the event of temperature differences ( $\Delta T$ ) between the supply air and room air temperatures.

Diffusion grille with **automatic** temperature-dependent air stream deflection.

Two different automatically regulating temperature indicators are available for the DGSELF:

- **Temperature indicator type 34**  
with pivoting angle of lamellae per  $1K=4^\circ$   
(for supply air temperature  $10^\circ$  until  $34^\circ C$   
max. permissible temperature= $50^\circ C$ )
- **Temperature indicator type 50**  
with pivoting angle of blades per  $1K=2,5^\circ$   
(for supply air temperature  $10^\circ$  until  $50^\circ C$   
max. permissible temperature= $75^\circ C$ )

For the choice of the temperature indicator two things are important:

- pivoting angle of blades per  $1K$
- max. air temperature in the pipe for supply air

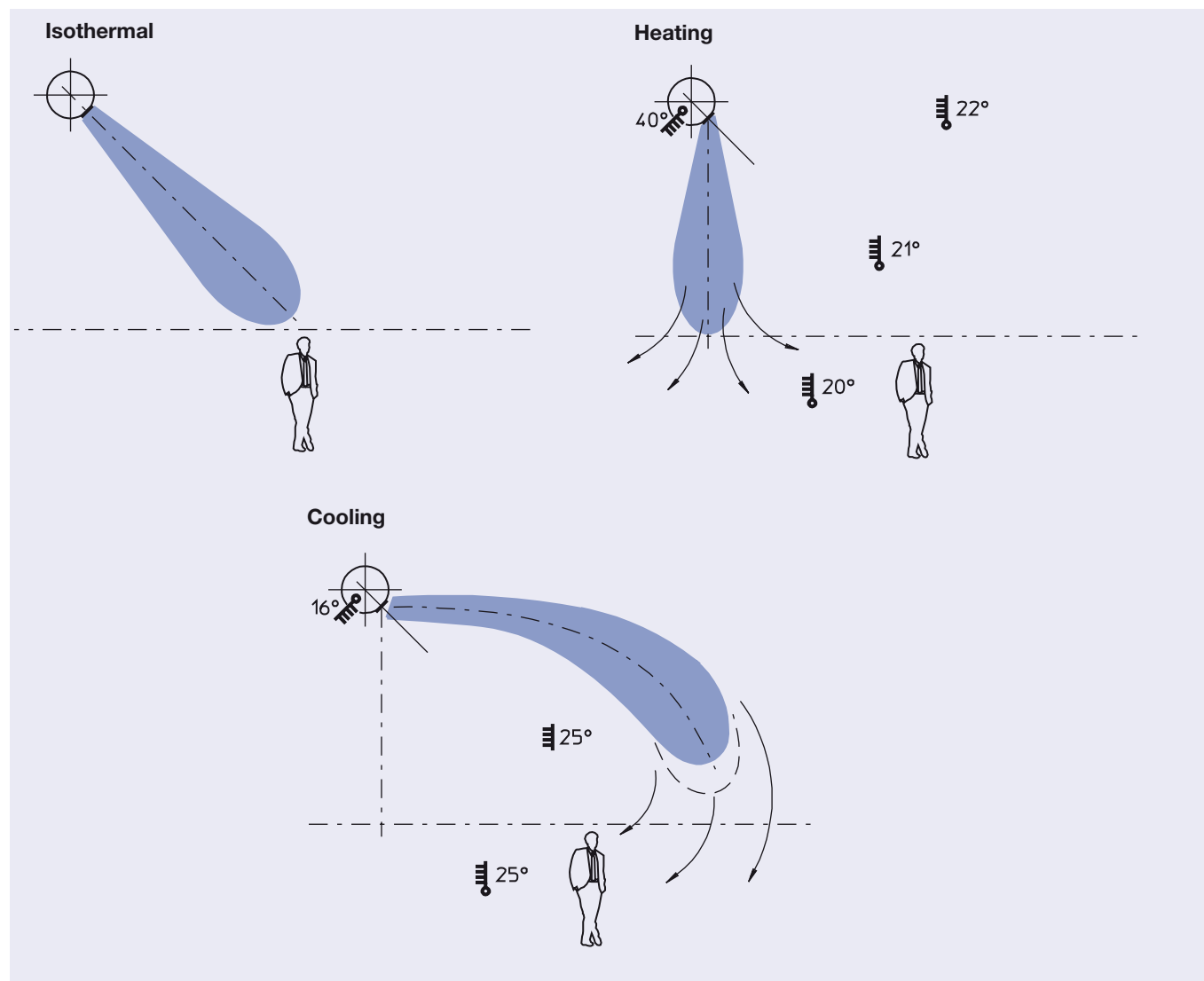

## Realisation

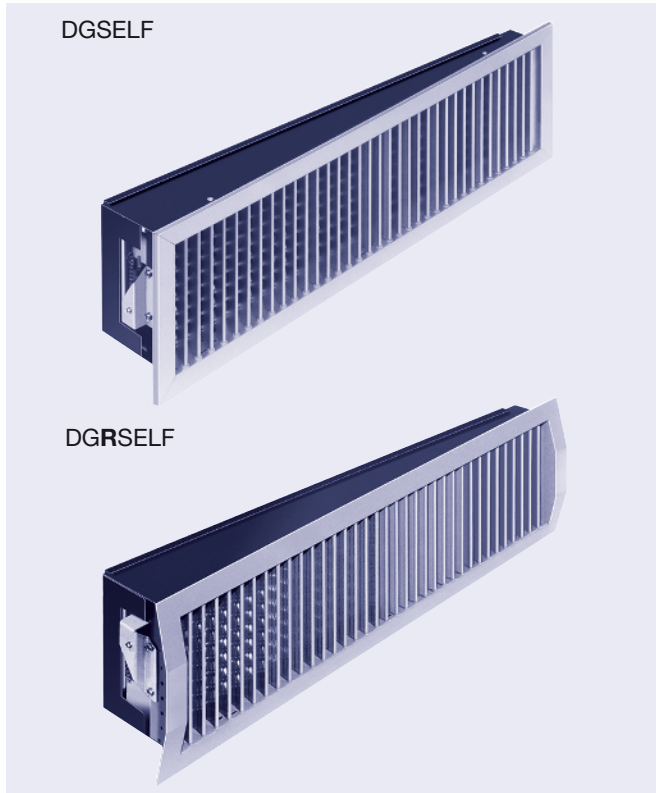

**DGSELF 5**  
Steel, powder-coated RAL 9010, silky sheen, 60% brilliance, with screw holes, consisting of: diffusion grille steel DG 5 with adjustable horizontal set of aluminium blades.

**DGLSELF 5**  
Colourless anodised aluminium, attachment by clips, consisting of: diffusion grille aluminium DGL 5 with adjustable horizontal set of aluminium blades.

**DGRSELF 5 and DGRASELF 5 (pipe duct)**  
Grey steel, steel, powder coated, galvanised silver, 25% brilliance, with screw holes, attachment by clips, consisting of: diffusion grille DGR 5 or DGRA 5 of steel for pipe ducts, with adjustable horizontal set of aluminium blades.

### Definition of left / right grilles type LI (left grille)

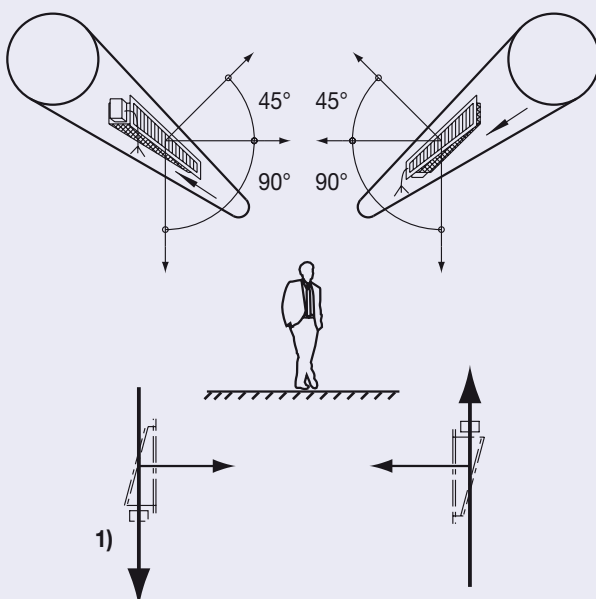

### Definition of left / right grilles type RE (right grille)

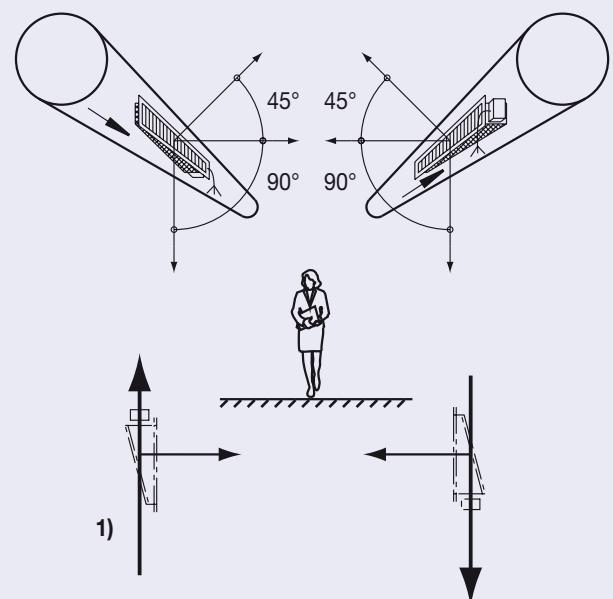

1) Direction of air stream

# Position of blades

## Position of blades of DGSELF

The adjustment of the rear blade position at a certain temperature is effected from the outside by means of a base regulating screw and DGSELF adjusting key. The max. working angle of the horizontal blades is approx. 116°. The base regulating screw is guarded against overturning.

The base regulating screw is guarded against overturning. Figures 7 until 12 show the different positions of the blades.

## Temperature indicator type 34

Adjustability on regulating screw max. 7,5 mm  
(1 mm=11,25°)

**Pivoting angle of blades per 1K=4°**

Max. permissible temperature=50°C

## Temperature indicator type 50

Adjustability on regulating screw max. 7,5 mm  
(1 mm=11,25°)

**Pivoting angle of blades per 1K=2,5°**

Max. permissible temperature=75°C

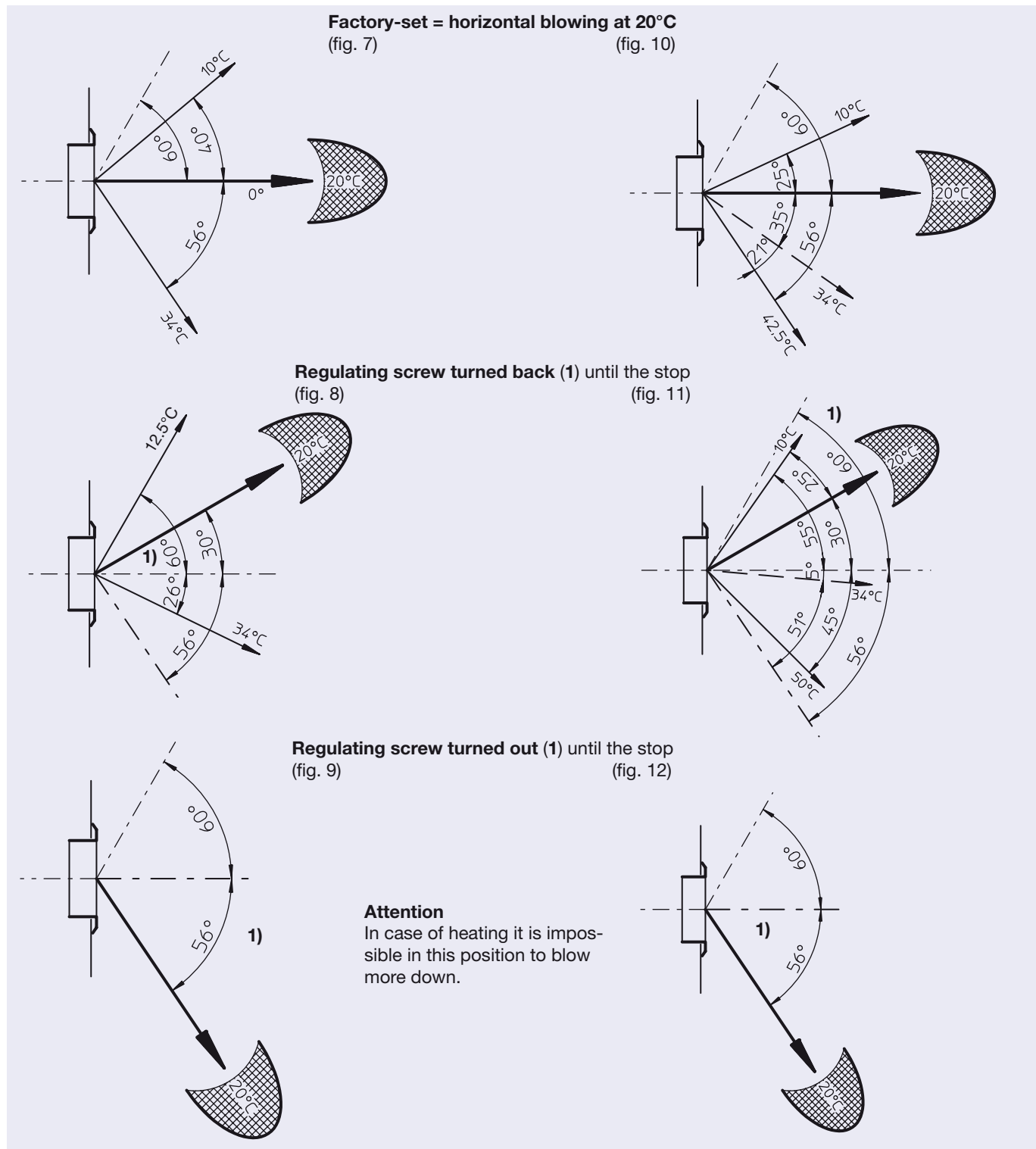

## Dimensions, Recess

Nominal size of grille: width B x height H in mm

DGSELF5, DGLSELF5, DGRSELF5, DGRASELF5

DGSELF  
DGLSELF

B	F	T	x	y
[mm]	[mm]	[mm]	[mm]	[mm]
600	283,5	110	max.	max.
750	358,5	130	15	8
900	433,5	150		

H	S
[mm]	[mm]
100	-
150	75
200	
250	

DGRSELF  
DGRASELF

B	F	T	x	z
[mm]	[mm]	[mm]	[mm]	[mm]
600	283,5	125	max.	max.
750	358,5	145	15	3

H	S
[mm]	[mm]
100	42
150	48
200	53
250	58

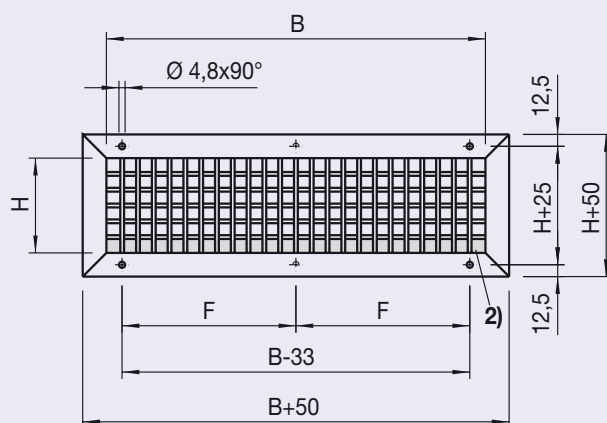

DGSELF...  
DGLSELF...

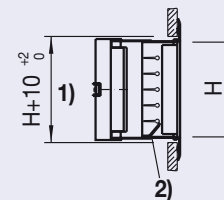

DGRSELF...  
DGRASELF...

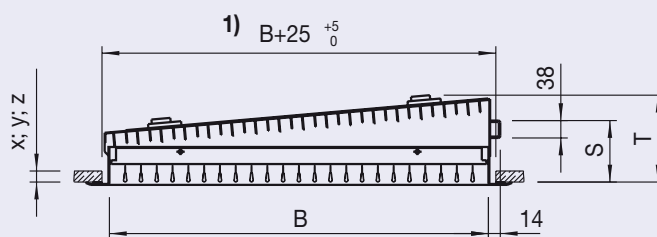
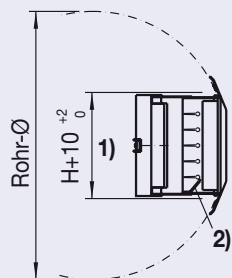

- 1) Recess
- 2) Blind blade below
- x DGSELF, DGRSELF a. DGRASELF with attachment by screw
- y DGSELF with attachment by clips SL
- z DGRSELF a. DGRASELF with attachment by clips SL



## Text for tendering purposes

### DGSELF 5

Diffusion grilles for temperature-dependent air stream deflection with vertical front blades which can be adjusted individually with a key. Rear horizontal blades self-adjusting by means of temperature indicator. Diagonally mounted aluminium slide box as throttle and directional control.

Type DGSELF 5 (L or R, type 34, 50)

Grey steel, powder-coated RAL 9010, silky sheen, 60% brilliance, with screw holes, with an adjustable set of horizontal aluminium blades.

Dimensions: B x H mm

Position of front blades: divergent by 0°, 44°, 84°, 110° or 140° or opposing.

### DGLSELF 5

Diffusion grilles for temperature-dependent air stream deflection with vertical front blades which can be adjusted individually with a key. Rear horizontal blades self-adjusting by means of temperature indicator. Diagonally mounted aluminium slide box as throttle and directional control.

Type DGLSELF 5 (L or R, type 34, 50)

Colourless anodized aluminium, attachment by clips, with an adjustable set of horizontal aluminium blades.

Dimensions: B x H mm

Position of front blades: divergent by 0°, 44°, 84°, 110° or 140° or opposing.

### DGRSELF 5 or DGRASELF 5

Diffusion grilles for mounting in pipe ducts for temperature-dependent air stream deflection with vertical front blades which can be adjusted individually with a key. Rear horizontal blades self-adjusting by means of temperature indicator. Diagonally mounted aluminium slide box as throttle and directional control.

Type DGRSELF 5 or DGRASELF 5 (L or R, type 34, 50)

Steel, powder coated, galvanised silver, 25% brilliance, with screw holes and attachment by clips, with an adjustable set of horizontal aluminium blades.

Dimensions: B x H mm

Position of front blades: divergent by 0°, 44°, 84°, 110° or 140° or opposing.

### Dimensioning

See dimensioning of TROX HESCO diffusions grilles (isothermal case)

### Caution

**In smoke test never use acid-containing substances!**

# Order Details

## Order codes

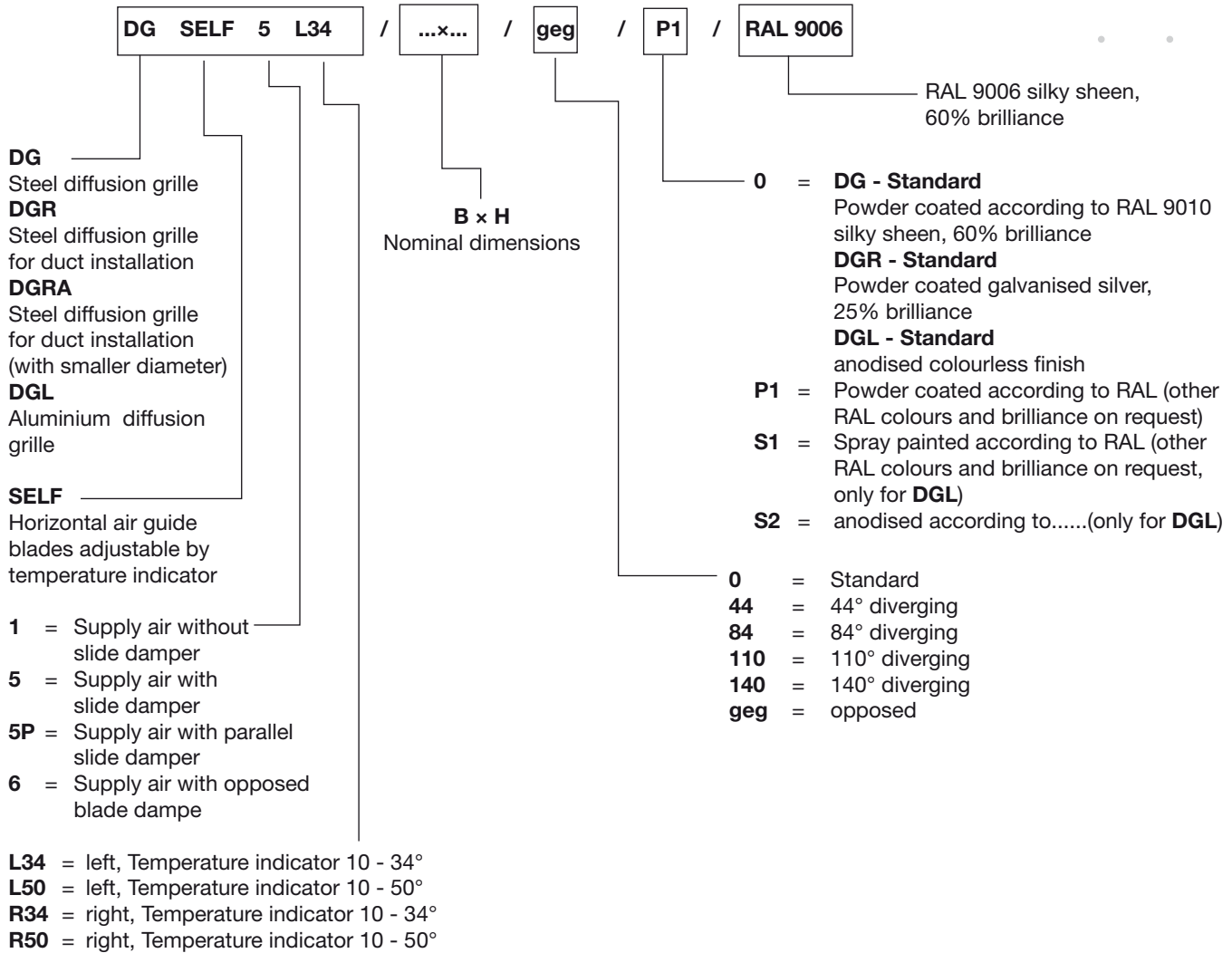

## Order examples

- 19 off DG SELF 5 L34 / 750 × 150 / 110
- 25 off DGL SELF 5 R50 / 900 × 200 / 84 / S1 / RAL9006
- 21 off DGR SELF 5 L34 / 750 × 150 / 110
- 13 off DGRA SELF 5 R34 / 600 × 150 / 140 / P1 / RAL9010