



# Electronic actuator with Modbus RTU

## X-VALVE-MOD-KP-MD15-RZ-J6

Modbus communication interface



X-AIRCONTROL – Modbus zone module



Small valve - optional accessory for the actuator

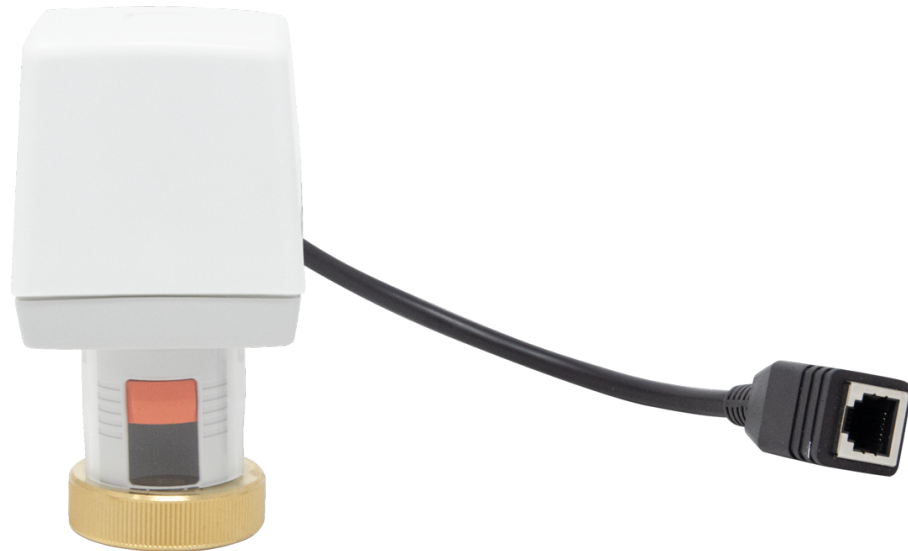

### For the secondary treatment of air, downstream of heating and cooling coils in water-side applications, in defined zones, offices and meeting rooms

Electronic actuator used for the modulating control of room temperature and extract air temperature in various water-based applications with 2/3" directional control valves

- Electronic actuator with Modbus interface
- LED for indicating the operating status
- DIP switches for setting the communication parameters
- Display of actual values, setpoint values and status via Modbus
- Automatic closing point detection and valve calibration
- Modulating control of the control signal and hence of the valve position (0 - 100%), feedback via Modbus
- Automatic valve anti block function prevents the spindle from blocking if the valve remains idle for a prolonged period of time
- Automatic flushing
- Analogue inputs (can be configured) for two temperature sensors
- Automatic leak detection based on the flow and return temperatures
- Spindle without a spring, hence low wear, for exact positioning

General information	2	Variants	6
Function	3	Technical data	8
Specification text	4	Product details	16
Order code	5		

## General information

### Application

- For the secondary treatment of air, downstream of heating and cooling coils in water-side applications of HVAC systems, in defined zones, offices and meeting rooms
- Electronic actuator for RZ/RWZ valves, used for the modulating control of room temperature and extract air temperature in various water-based applications
- Small actuator for modulating control procedures in heating, ventilation and air conditioning systems

### Special features

- Communication and signalling via Modbus RTU
- RJ12 connection for easy plug and play
- Ideal for the TROX X-AIRCONTROL system
- LED for indicating operating status and faults
- DIP switches for setting bus parameters
- Automatic detection of the closing point
- Leak detection by means of flow and return temperature measurement
- Automatic flushing
- Valve anti block function
- Maintenance-free

### Interface

Digital communication interface (bus)

- Modbus RTU for communication and signalling

Analogue interface

- 2 analogue inputs (e.g. for temperature sensors)

### Variants

- Electronic actuator suitable for 2-way and 3-way valves

### Parts and characteristics

- Electronic actuator for encased valves
- Valve calibration for DN 10 – 32
- Electrical connection with terminals or plug-in cables
- Factory fitted cable with RJ12 socket for the connection to X-AIRCONTROL

### Construction features

- Valve connection with M30 × 1.5 thread
- Electrical connection points with removable cover
- 2 casing cover variants (with 1 or 2 cable entry points)
- Simple connection to the X-AIRCONTROL Modbus zone module with plug and play

### Materials and surfaces

- Casing top made of plastic, PC, UL 94 V-0, RAL 9003
- Casing bottom made of plastic, PTB, UL 94 V-0, RAL 7035
- Valve connection with M30 × 1.5 thread

### Useful additions

- X-AIR-ZMO-MOD Modbus zone module for room control



## Function

For the secondary treatment of air, downstream of heating and cooling coils in water-side applications of HVAC systems, in defined zones, offices and meeting rooms. Electronic actuator for

RBQ/QTZ valves, used for the modulating control of room temperature and extract air temperature in various water-based applications

**Installation example: TROX X-VALVE Modbus (RTU) used with TROX DID and zone module X-AIR-ZMOMOD**

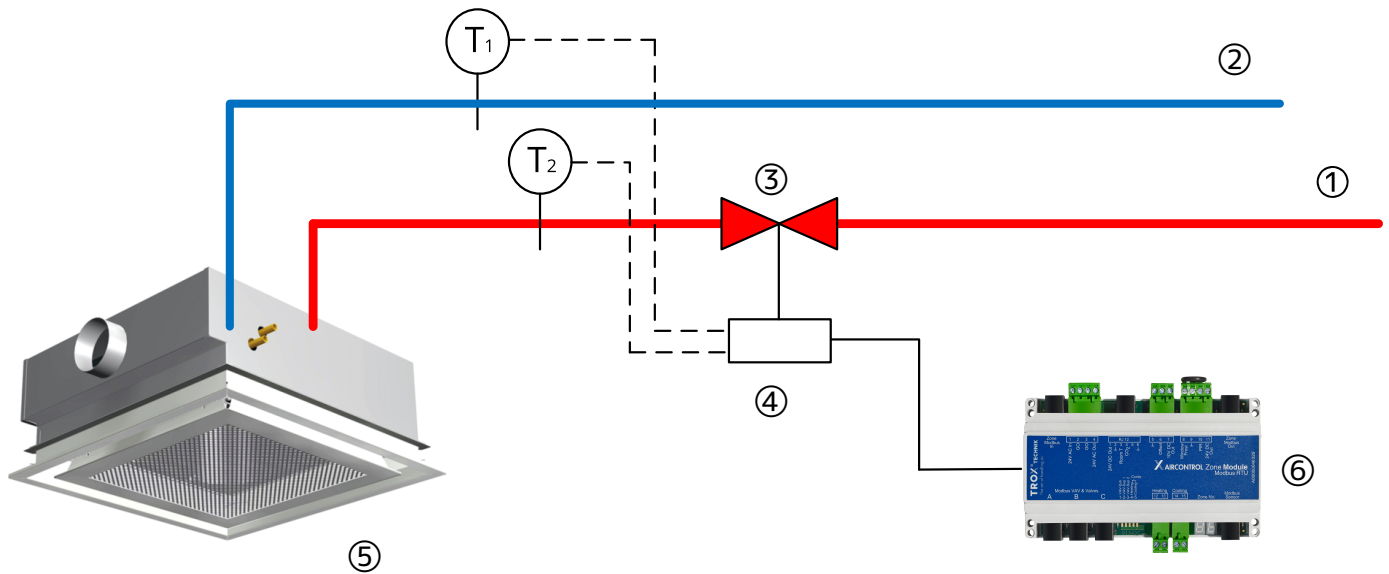

- ① Water flow
- ② Water return
- ③ Small valve
- ④ Modbus (RTU) actuator for small valve
- ⑤ TROX DID604 active chilled beam
- ⑥ TROX Modbus (RTU) zone module X-AIR-ZMO-MOD for single room control
- T<sub>1</sub> = optional analogue temperature sensor in the water return
- T<sub>2</sub> = optional analogue temperature sensor in the water flow

## Specification text

This specification text describes the general properties of the product. Texts for variants can be generated with our Easy Product Finder design program.

### Specification text

Small actuator with Modbus RTU interface (RS485) for the modulating control of zone-based secondary treatment devices in HVAC systems.

### Special features

- Communication and signalling via Modbus RTU
- RJ12 connection for easy plug and play
- Ideal for the TROX X-AIRCONTROL system
- LED for indicating operating status and faults
- DIP switches for setting bus parameters
- Automatic detection of the closing point
- Leak detection by means of flow and return temperature measurement
- Automatic flushing
- Valve anti block function
- Maintenance-free

### Interface/signalling

- Modbus RTU interface (RS 485)

### Electrical connection

- RJ12 socket as standard, alternatively screw terminals

- Can be connected to an X-AIR-ZMO-MOD zone module simply by plug and play
- 2 universal inputs, e.g. for temperature measurement (flow and return temperatures)

### Supply voltage

- 24 V AC/DC  $\pm 10\%$  with RJ12 connection
- When used with X-AIRCONTROL, the power is supplied via the zone module

### Water-side connection

- Positive lock connection M30  $\times$  1.5; DIN 13
- For RZ/RWZ control valves, spindle without a spring

### Factory condition

- Electric actuator:
- Factory fitted RJ12 connector for simple plug and play
- Special cover with a second cable entry point
- Factory fitted connecting cable for sensors
- Product description

### Dimensions

Height: 75 mm

Width: 48.5 mm

Depth: 86.5 mm



Order code

X-VALVE – MOD – KP-MD15-RZ-J6  
|            |            |  
1            2            3

**1 Type**

X-VALVE

**2 Interface**

ANA (analogue)

MP (MP bus)

MOD (Modbus RTU)

**3 Type of actuator**

KP-MD15-Q-J6

KP-MD15-RZ-J6

**Order example: X-VALVE-MOD-KP-MD15-RZ-J6**

Type

X-VALVE

Interface

MOD

Type of actuator

KP-MD15-RZ-J6

## Variants

X-VALVE-MOD-KP-MD15-RZ-J6 with open cover

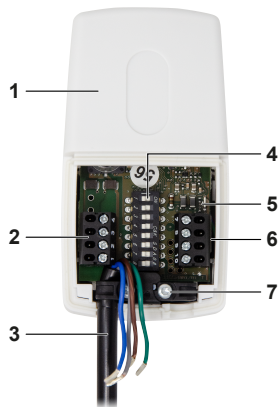

- 1: X-VALVE-MOD casing
- 2: Terminal strip
- 3: 4-wire cable at RJ12 socket
- 4: DIP switches
- 5: Status LED, green / yellow / red
- 6: Terminal strip
- 7: Strain relief

X-VALVE-MOD-KP-MD15-RZ-J6 with open cover, detail

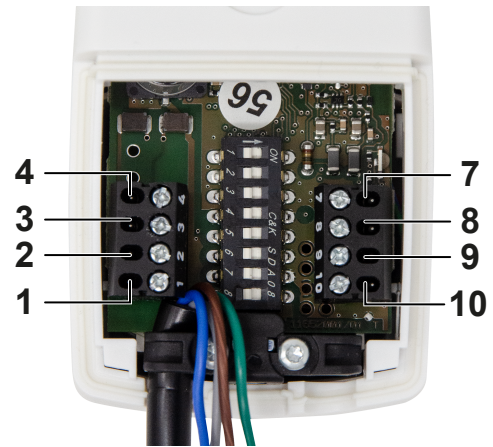

- 1: 24 V AC/DC (blue)
- 2: GND 0 V (brown)
- 3: Modbus RTU D+ (green)
- 4: Modbus RTU D- (grey)
- 7: Universal input 1 (white)
- 8: GND for universal input 1 (purple)
- 9: Universal input 2 (grey)
- 10: GND for universal input2 (pink)

X-VALVE-MOD-KP-MD15-RZ-J6, front view

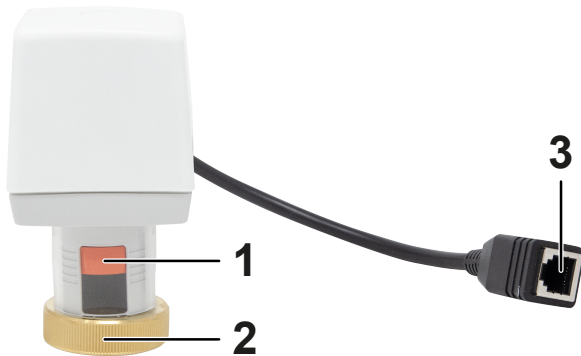

- 1 = Release button and position indicator
- 2 = Union nut M30 × 1.5
- 3 = RJ45 socket

Two covers (part of the supply package)



- 1: Cover with 2 cable entry points
- 2: Cover with 1 cable entry point

4-wire sensor cable (part of the supply package)



Optional accessory: Valve PN 16, DN 15



## Technical data

Order code	Part number	Type
X-VALVE-MOD-KP-MD15-RZ-J6	A00000073470	KP-MD15-RZ-J6

**X-VALVE-MOD-KP-MD15-RZ-J6, electronic actuator for small valves**

**X-VALVE-MOD-KP-MD15-RZ-J6, electronic actuator for small valves**

Supply voltage	24 V AC $\pm 10\%$ , 50/60 Hz
Supply voltage (DC)	24 V DC $\pm 10\%$
Power rating (AC)	3.8 VA
Power rating (DC)	1.9 W
Interface	RS-485 Modbus RTU slave
Control input signal	Modbus RTU (RS-485)
Inputs and outputs	2 universal inputs or outputs (P1, P2) via Modbus, can be configured individually as: - binary input, volt-free, 500 $\Omega$ , 1 mA max.; 13 V DC - analogue input, see table with sensor types - output 0 – 10 V only P2
Voltage and communication connection	Factory fitted cable with RJ12 socket / terminals, approx. 30 cm
Connection of inputs/outputs	Terminals up to 0.5 mm <sup>2</sup>
Display	LED for indicating faults scale for valve stroke on the outside
Actuator noise	< 31 dB(A)
Actuator stroke	9 mm max.
Actuator force	150 N, nominal
Acceptable water temperature	0 °C – 120 °C
Ambient temperature	0 °C to 50 °C
Humidity	No condensation
Protection level	IP 54
IEC protection class	III according to EN 60730
Installation orientation	360 °
Maintenance	Maintenance-free
Weight	Approx. 350 g

**Installation and commissioning**

- Installation only in heating, ventilation and air conditioning systems indoors
- Supplied ready for installation (with the spindle retracted)
- Do not switch on the power supply until the actuator has been installed on the valve
- Tighten the union nut only finger-tight
- Setting Modbus addresses with DIP switches 1 - 6
- LED for indicating the operating status
- Maintenance-free actuator

**Disassembly; unscrew the actuator**

- Let valve and actuator cool down
- Set DIP switches 1 – 6 to OFF
- LED blinking rapidly, green
- Interrupt the supply voltage
- Disconnect all electrical connections
- Loosen the union nut
- Remove the actuator from the valve

**Setting Modbus addresses 1 - 63 with the DIP switches**

Address	DIP 6 (bit 5)	DIP 5 (bit 4)	DIP 4 (bit 3)	DIP 3 (bit 2)	DIP 2 (bit 1)	DIP 1 (bit 0)
1						1
2					1	
3					1	1
4				1		
Other						
...						
63	1	1	1	1	1	1

**Note:** After the addressing has been adjusted, an initialisation run is always carried out.





## Communication interface Modbus RTU

Register	Who	Description	R/W
	Setpoint value	0 – 10000 (0.0 – 100.0 %)	R/W
1	Override control	0 = none 1 = open 2 = close 3 = minimum position 5 = maximum position	
2	Command	0 = normal 1 = initialisation 2 = test 3 = sync 4 = ErrReset 5 = BaudrateChange	R/W
3	Actuator type	201	R
5	Absolute position (mm)	in mm (* 10)	R
8	Flow temperature	in °C (* 10), actual flow temperature	R
107	Return temperature	in °C (* 10), actual return temperature	R
141	Temperature difference P1/P1	in K (*10), temperature difference between flow and return	R
125	Correction value P1	V (* 100); °C (* 10)	R/W
128	Correction value P2	V (* 100); °C (* 10)	R/W
145	Configuration of sources for differential temperature calculation	0 = flow and return temperatures: bus register value 1 = flow: P1; return: P2 2 = flow: P2; return: P1 3 = flow: P1; return: bus 4 = flow: P2; return: bus 5 = flow: bus; return: P1 6 = flow: bus; return: P2	R/W
105	Minimum stroke	0 – 10000 (0 – 100) (minimum stroke) (0 = default)	R/W
106	Maximum stroke	0 – 10000 (0 – 100) (maximum stroke) (10000 = default)	R/W
140	Hardware	0x00XX = MD15MOD-Q 0x01XX = MD50MOD 0x02XX = MD15MOD-RZ	R
100	Serial number 1	0 – 65535	R
101	Serial number 2	0 – 65535	R
102	Serial number 3	0 – 65535	R
103	Firmware version	0 – 65535	R
104	Operating state	0x0000: Normal, fault-free operation 0x0001 = fault, internal memory 0x0002 = fault, internal A/D conversion 0x0004 = valve calibration error 0x0008 = fault, internal motor 0x0010 = P1 limit exceeded 0x0020 = P2 limit exceeded 0x0100 = communication, test run/calibration in process	R
147	RS-485 baud rate	0 = default (38,400, 8, N, 2) 1 = 9600 2 = 19200 3 = 38400 4 = 57600 5 = 115200	R/W
148	RS-485 stop bits	1; 2	R/W



Register	Who	Description	R/W
149	RS-485 parity	0 = none 1 = even 2 = odd	R/W
407	Leakage warning	0 = none; 1 = leak detected, (> 8 K temperature difference between flow and return over 6 hours)	R
135	Flushing timer	Value in minutes (0; 60 – 32767 minutes) 0 = inactive (default) 60 = smallest interval 32767 = largest interval	R/W
319	Flushing timer – time remaining until next flushing procedure	Value in minutes (0 – 32767 minutes)	R
136	VBS time (valve anti block function)	Value in hours (0; 24 – 4320) 0 = inactive 24 = smallest interval 4320 = largest interval	R/W
320	VBS time until next flushing procedure	Value in hours (1 – 4320)	R
123	Sensor type P1	0 = off 1 = binary input 2 = 0 – 10 V 3 = KP10 4 = Ni1000 5 = Ni1000LG 6 = PT1000 (default)	R/W
425	Sensor type P2	0 = off 1 = binary 2 = 0 – 10 V 3 = KP10 4 = NI1000 5 = NI1000LG 6 = PT1000 (default) 8 = Y output 0 – 10 V (register 426 = 0 – 1000) 9 = Y feedback 0 – 10 V	R/W
426	Y at output P2	Voltage value (0 – 1000) for a 0 – 10 V output signal at terminal P2 (if register 425 = 8; P2 = output 0 – 10 V)	R

R = Read-only access to register

R/W = Read/write access to register

**Note:**

Supported Modbus functions 0x03 Read Holding Register

0x06 Write Holding Register

0x03 Read Holding Multiple

0x10 Write Holding Multiple

Terminal strips and DIP switches

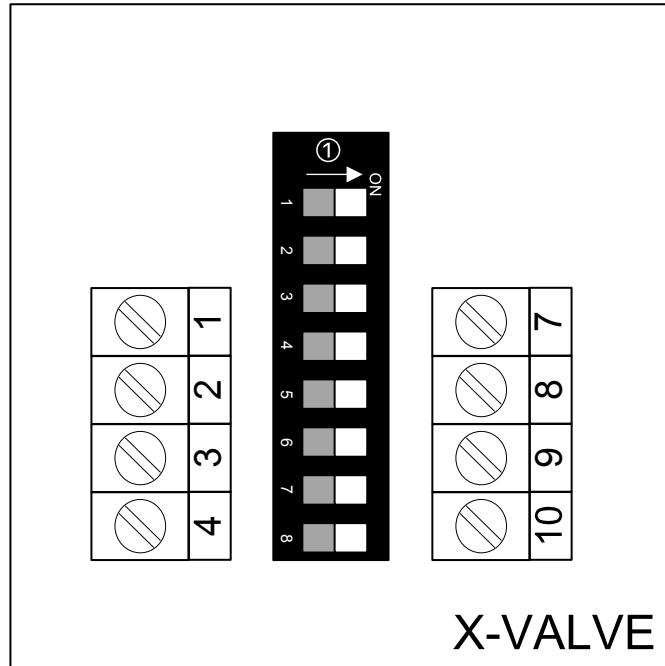

- 1: ~, +, supply voltage 24 V AC/DC
- 2: ⊥, -, ground, neutral
- 3: D+ Modbus RTU
- 4: D- Modbus RTU

- 7: Universal input 1
- 8: Ground, GND
- 9: Universal input 2
- 10: Ground, GND
- Ⓛ: DIP switches 1 – 8

Connection diagram for pre-assembled cables

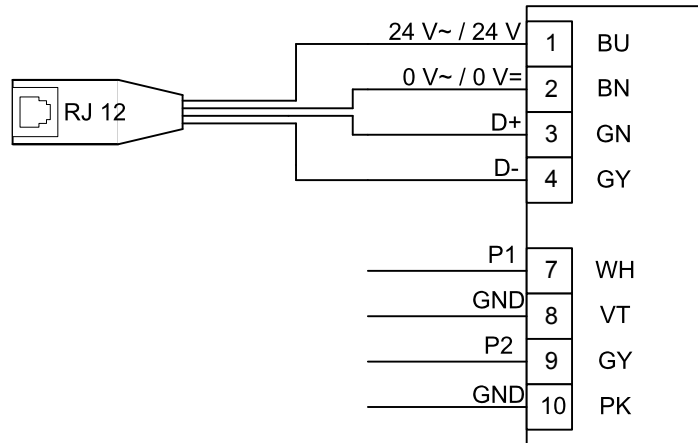

- 1: BU, supply voltage, 24 V
- 2: BN, ground, neutral, 0 V
- 3: GN, Modbus RTU, D+
- 4: GY, Modbus RTU, D-

- 7: WH, universal input 1
- 8: VT, ground, GND
- 9: GY, universal input 2
- 10: PK, ground, GND

**Note:** Plug-in cables are part of the supply package.

Modbus RTU connections, one voltage source

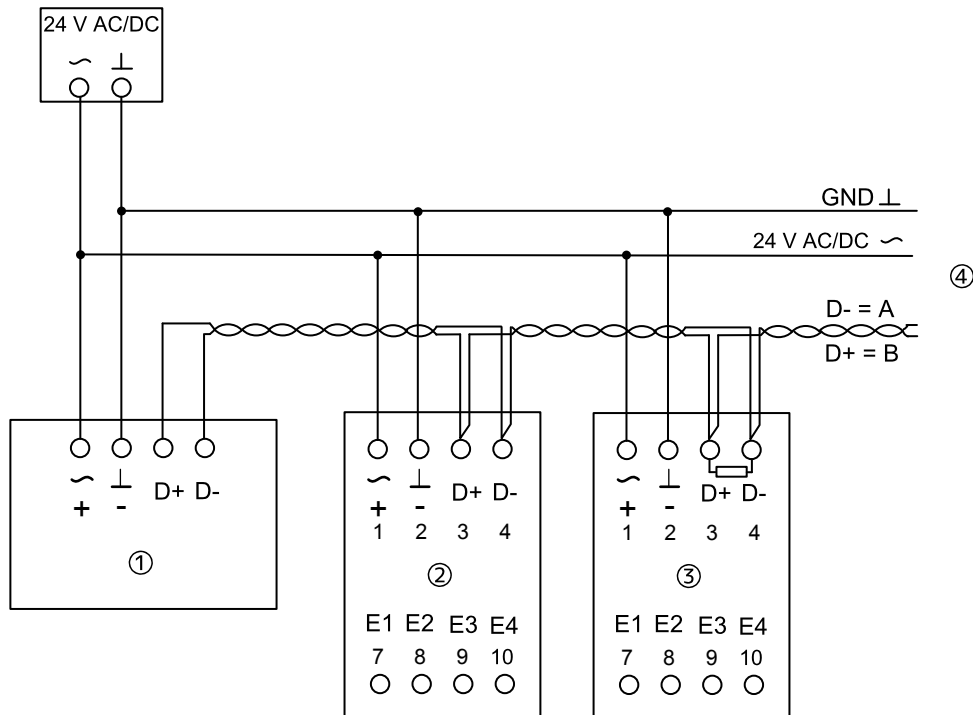

- ① Modbus RTU master
- ② Modbus RTU slave, e.g. X-VALVE
- ③ Modbus RTU slave 2, e.g. X-VALVE with terminal resistor, DIP switch 8
- ④ Other network devices

- 1: ~, + = supply voltage 24 V AC/DC
- 2: ⊥, - = Ground, neutral
- 3: D+ = Modbus RTU
- 4: D- = Modbus RTU

- Note:**
- Electrical connection only with safety transformer
  - Modbus wiring only according to the relevant RS485 guidelines
  - Supply voltage and communication must not be galvanically isolated. All electric devices have to be connected to the same GND signal.

Modbus RTU connections, several voltage sources

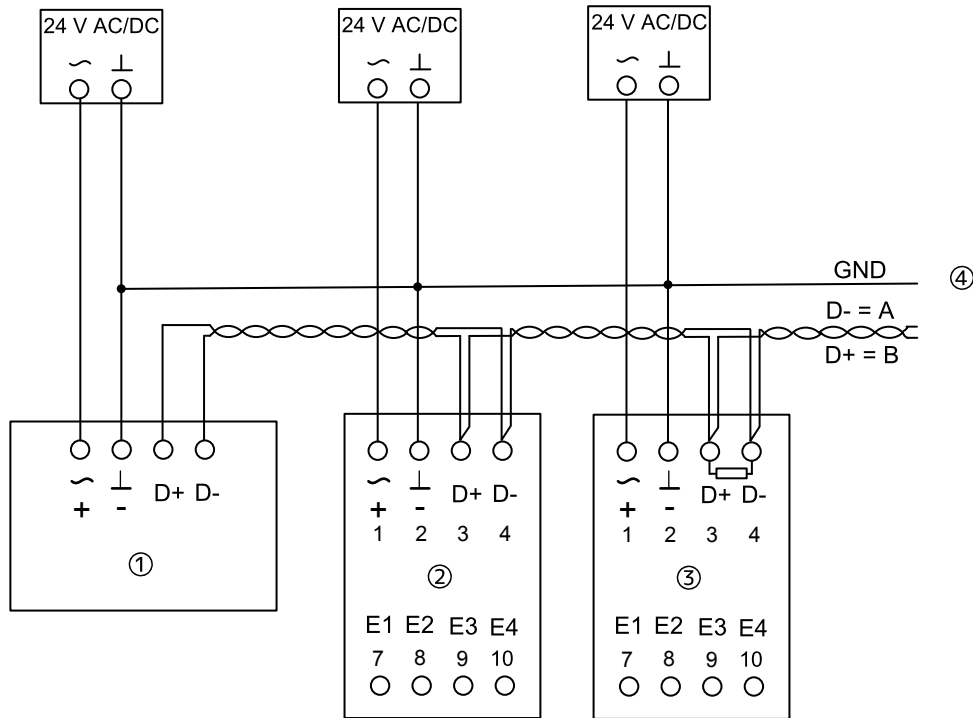

- ① Modbus RTU master
- ② Modbus RTU slave, e.g. X-VALVE
- ③ Modbus RTU slave 2, e.g. X-VALVE with terminal resistor, DIP switch 8
- ④ Other network devices

- 1: ~, + = supply voltage 24 V AC/DC
- 2: ⊥, - = Ground, neutral
- 3: D+ = Modbus RTU
- 4: D- = Modbus RTU

- Note:**
- Electrical connection only with safety transformer
  - Modbus wiring only according to the relevant RS485 guidelines
  - Supply voltage and communication must not be galvanically isolated. All electric devices have to be connected to the same GND signal.
  - If several voltage sources are being used, the GND of all the sources have to be connected.

## Product details

### Automatic detection of the closing point

The valve closing point is detected during the initialisation run. During operation, a cyclical reinitialisation takes place.

### Positioning

The actuator is a modulating actuator. The control signal (0 – 100%) is transmitted via Modbus communication. The current position (0 – 100 %/mm) can be queried via Modbus.

### Valve anti block function

The actuator has a valve anti block function that can be switched on. The cycle time can be set or changed as part of Modbus parameter setting. If the value is 0, this function is deactivated. The automatic valve anti block function prevents the spindle from blocking if the valve remains idle for a prolonged period of time

### Temperature measurement

The flow and return temperatures can be captured with two temperature sensors and queried via Modbus.

### Flushing

The actuator has a function for automatic flushing. The valve opens fully for the flushing procedure. The cycle time can be set or changed as part of Modbus parameter setting. If the value is 0, this function is deactivated.

### Leak detection

Automatic leak detection based on the flow and return temperatures and with the valve being closed. A temperature difference greater than 8 K for at least 6 hours with the valve closed indicates a leak.

### Indication of operating status and faults

Operating status and fault signals are captured by the actuator and can be queried via Modbus. This data helps to assess the condition of the hydraulic system and detect faults at an early stage.