

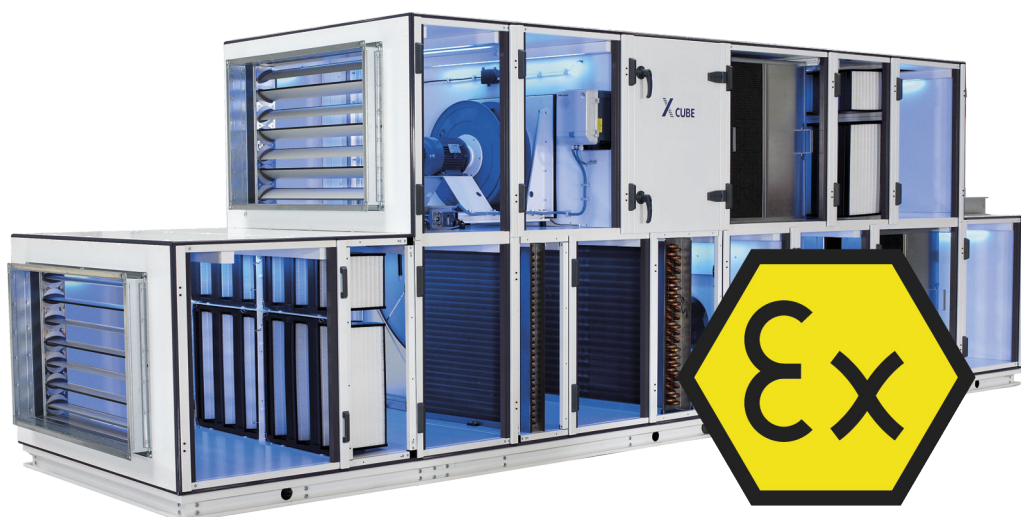

Air handling unit

X-CUBE Ex

for areas with potentially explosive atmospheres



TROX[®] TECHNİK
The art of handling air

TROX GmbH
Heinrich-Trox-Platz
47504 Neukirchen-Vluyn, Germany
Germany
Telephone: +49 (0) 2845 202-0
Fax: +49 (0) 2845 202-265
E-mail: trox@trox.de
Internet: www.trox.de

A00000057819, 2, GB/en
10/2021

© TROX GmbH 2016

Information on the transportation and installation manual

This transport and installation manual enables operating or service personnel to use the X-CUBE Ex air handling unit (AHU) safely and efficiently in potentially explosive atmospheres.

The manual must be kept near the unit to be available for use at all times.

This transport and installation manual is intended for use by fitting and installation companies, operators, in-house technicians, technical staff or properly trained persons, and skilled qualified electricians or air conditioning technicians.

It is essential that these individuals read and fully understand this manual before starting any work. The basic prerequisite for safe working is to comply with the safety notes and all instructions in this manual.

The local regulations for health and safety at work and the general safety regulations for the area of application of the air handling unit also apply.

Illustrations in this transport and installation manual are mainly for information and may differ from the actual design of the air handling unit.

Other applicable documentation

In addition to these instructions, the following documents apply:

- Order-specific approval drawing
- Order-specific air handling unit data sheet from TROX
- Data sheets for components from other suppliers, if any
- Additional drawings, if any
- X-CUBE-Ex operating manual

TROX Technical Service

To ensure that your request is processed as quickly as possible, please keep the following information ready:

- Product name
- TROX order number
- Delivery date
- Brief description of the fault

Online	www.troxtechnik.com
Phone	+49 2845 202-400

Copyright

This document, including all illustrations, is protected by copyright and pertains only to the corresponding product.

Any use without our consent may be an infringement of copyright, and the violator will be held liable for any damage.

This applies in particular to:

- Publishing content
- Copying content
- Translating content
- Microcopying content
- Saving content to electronic systems and editing it

Limitation of liability

The information in this manual has been compiled with reference to the applicable standards and guidelines, the state of the art, and our expertise and experience of many years.

The manufacturer does not accept any liability for damages resulting from:

- Non-compliance with this manual
- Incorrect use
- Operation or handling by untrained individuals
- Unauthorised modifications
- Technical changes
- Use of non-approved replacement parts

The actual scope of delivery may differ from the information in this manual for bespoke constructions, additional order options or as a result of recent technical changes.

The obligations agreed in the order, the general terms and conditions, the manufacturer's terms of delivery, and the legal regulations in effect at the time the contract is signed shall apply.

We reserve the right to make technical changes.

Warranty claims

The provisions of the respective general delivery terms apply to warranty claims. For purchase orders placed with TROX GmbH, these are the regulations in section "VI. Warranty claims" of the Delivery Terms of TROX GmbH, see www.trox.de/en/.

Safety notes

Symbols are used in this manual to alert readers to areas of potential hazard. Signal words express the degree of the hazard.

Comply with all safety instructions and proceed carefully to avoid accidents, injuries and damage to property.

DANGER!

Imminently hazardous situation which, if not avoided, will result in death or serious injury.

WARNING!

Potentially hazardous situation which, if not avoided, may result in death or serious injury.

CAUTION!

Potentially hazardous situation which, if not avoided, may result in minor or moderate injury.

NOTICE!

Potentially hazardous situation which, if not avoided, may result in property damage.

ENVIRONMENT!

Environmental pollution hazard.

Tips and recommendations



Useful tips and recommendations as well as information for efficient and fault-free operation.

Specific safety notes



The following symbols are used in safety notes to alert you to specific hazards:

Warning signs	Type of danger
	Warning - danger of crushing.
	Warning – hand injuries.
	Warning – high-voltage.
	Warning – explosive atmosphere.
	Warning – danger of falling.
	Warning – suspended load.
	Warning – danger zone.

Additional markers

In order to highlight instructions, results, lists, references and other elements, the following markers are used in this manual:

Marker	Explanation
 1., 2., 3. ...	Step-by-step instructions
	Results of actions
	References to sections in this manual and to other applicable documents
	Lists without a defined sequence
[Switch]	Operating elements (e.g. push buttons, switches), display elements (e.g. LEDs)
'Display'	Screen elements (e.g. buttons or menus)

1	Overview	6	5.6.4 Equipotential bonding	43
2	Safety	7	5.6.5 Lightning protection for outdoor units ...	43
	2.1 System owner's responsibility	7	5.7 Integrating the air handling unit with the	
	2.2 Personnel requirements	7	central BMS	43
	2.3 Personal protective equipment	8	6	Initial commissioning
	2.4 Residual risks	9		44
	2.5 Behaviour in the event of hazardous situa-	10	6.1 Safety notes regarding initial commis-	
	tions or accidents	10	sioning	44
	2.6 Replacement parts	11	6.2 Before initial commissioning	44
3	Transport and storage	12	6.3 Setting up and adjusting AHU casing units	
	3.1 Delivery of the air handling unit	12	45
	3.1.1 Complete and partial units	12	6.3.1 Inspection access doors	45
	3.1.2 Symbols on the packaging	12	6.3.2  Centrifugal fan	46
	3.2 Delivery check	12	6.3.3  Filter	48
	3.3 Moving packages	13	6.3.4  Heating coil/cooling coil	49
	3.3.1 Safety notes regarding transport	13	6.3.5  Run around coil system	50
	3.3.2 Moving packages with a forklift or pallet	14	6.3.6  Multileaf dampers	51
	truck	14	6.3.7  Sound attenuator	52
	3.3.3 Moving packages with a crane	15	6.3.8  Plate heat exchanger	52
	3.4 Storing packages	20	6.3.9 Electrical system	53
	3.5 Unpacking	20	6.4 Starting the air handling unit	53
4	Setup and assembly	22	6.4.1 Before you start the AHU	53
	4.1 Safety instructions	22	6.4.2 Starting	53
	4.2 Installation location, requirements	23	7	Removal and disposal
	4.2.1 Requirements for indoor installation	23		54
	4.2.2 Requirements for outdoor installation ...	24	7.1 Safety notes regarding disassembly and	
	4.3 Preventing vibration and structure-borne	25	disposal	54
	noise	25	7.2 Disassembly	56
	4.4 Setting up and assembling the air han-	25	7.3 Disposal	56
	dling unit	25	8	Glossary
	4.4.1 Setting up the AHU or AHU casing units	25		57
	25	9	Index
	4.4.2 Assembling AHU casing units	26		58
	4.4.3 Additional assembly steps for outdoor	29		Appendix
	units	29		60
	4.4.4 Connecting the ductwork	31	A	Supplier documents
	4.4.5 Installing accessories	32		61
5	Installation	33	A.1	Ziehl-Abegg RH..C / ER..C fan
	5.1 Safety notes regarding installation	33		61
	5.2 Before installation	34	A.2	Nicotra Gebhardt RLM... fan
	5.3 Sizing and connecting the condensate	34		74
	drain	34	A.3	Hoval
	5.4  Connecting the heating coil/cooling coil	37		123
	37	A.4	GEA pocket filter
	5.5  Connecting the run around coil system	38		126
	38	A.5	EMW compact filter
	5.6 Connecting the air handling unit to the	40		129
	power supply	40	A.6	Briem MD201 MB E 4301 Atex differential
	5.6.1 Electrical connection	41		pressure gauge
	5.6.2 Connecting multileaf dampers	41		132
	5.6.3 Fans used with a frequency inverter	42	A.7	Actuators
				134
			A.8	Anti-frost thermostat
				143
			A.9	Pressure switch/Differential pressure
				switch
				147
			A.10	Pressure sensors
				154

1 Overview



Fig. 1: X-CUBE overview

Each X-CUBE air handling unit consists of several casing units and components. The following table (↗ 'AHU components' on page 6) lists the components that can make up an air handling unit. The components and quantities actually used for the air handling unit are listed in the order-specific X-CUBE operating manual.

AHU components

Symbol	Meaning	Symbol	Meaning
	Heating coil		Multileaf dampers
	Cooling coil		Run around coil system
	Filter		Hydraulic unit for run around coil system (not explosion-proof)
	Centrifugal fan		Plate heat exchanger
	Sound attenuator		

2 Safety

2.1 System owner's responsibility

System owner

The system owner is a natural or legal person who for commercial or business purposes owns or manages the air handling unit or allows third parties to use or operate it, but continues to bear legal responsibility for the safety of users, staff or third parties while the product is in use.

System owner's obligations

The unit is intended for commercial use. The system owner is therefore subject to the legal obligations of occupational health and safety regulations.

In addition to the safety notes in this manual, the applicable regulations for safety, accident prevention and environmental protection must also be complied with.

In particular:

- The system owner must establish on site a coherent strategy for the prevention of explosions and include the air handling unit in this strategy.
- The system owner must establish on site a coherent fire protection strategy and include the air handling unit in this strategy.
- The system owner must establish on site a coherent lightning protection strategy and include the air handling unit in this strategy.
- The system owner must name responsible persons for transport, storage, assembly, installation, commissioning, transfer, disassembly and removal of the unit.
- The system owner must commission a skilled qualified electrician to create equipotential bonding.
- The system owner has to ensure that all individuals who handle or use the air handling unit have read and understood this manual.
- The system owner must provide the employees with the required personal protective equipment for areas with potentially explosive atmospheres.
- The system owner must have all safeguards tested regularly to ensure that they are functional and complete.
- The system owner must ensure compliance with the national legal provisions.
- The system owner must have technical and hygiene tests carried out and documented before commissioning the air handling unit for the first time. The tests have to be repeated at regular intervals.
- The system owner must comply with Directive 1999/92/EC on minimum requirements for improving the safety and health protection of workers potentially at risk from explosive atmospheres. This includes additional organisational measures such as:

- Designating areas with potentially explosive atmospheres.
- Creating an explosion protection document for each zone.
- Preventing unauthorised people from accessing the area or zone.
- Putting up warning signs.
- Allowing access by permit only for dangerous jobs to be carried out.

Risk of explosion

WARNING!

Explosion hazard!

If a component or device is to be installed in a system intended for use in potentially explosive atmospheres according to 2014/34/EU, the system owner has to ensure compliance of the entire system with that directive.

Non-compliance may lead to an explosion.

2.2 Personnel requirements

WARNING!

Danger of injury or risk of damage to property due to insufficiently qualified individuals!

Insufficiently qualified individuals are not aware of the risks involved in working with the air handling unit and are hence likely to put themselves or others into danger, causing severe or fatal injuries.

- Have any work carried out only by qualified personnel.
- Keep insufficiently qualified individuals away from the work area.

Crane driver

Crane drivers are physically and mentally able to operate a crane on their own.

Crane drivers are qualified to operate a crane and have proven the required skillset to the system owner.

Crane drivers are commissioned by the system owner to move units from the delivery truck to the installation location. Crane drivers are commissioned in writing if the crane is a mobile crane.

Crane drivers have to be at least 18 years old.

Forklift driver

Forklift drivers are qualified to operate driver-operated forklift trucks; they are commissioned in writing by the system owner to operate such a truck.

Forklift drivers are responsible for moving pallets.

HVAC technician

HVAC technicians are individuals who have sufficient professional or technical training in the field they are working in to enable them to carry out their assigned duties at the level of responsibility allocated to them and in compliance with the relevant guidelines, safety regulations and instructions. HVAC technicians are individuals who have in-depth knowledge and skills related to HVAC systems; they are also responsible for the professional completion of the work under consideration.

HVAC technicians are individuals who have sufficient professional or technical training, knowledge and actual experience to enable them to work on HVAC systems, understand any potential hazards related to the work under consideration, and recognise and avoid any risks involved.

Skilled qualified electrician

Skilled qualified electricians are individuals who have sufficient professional or technical training, knowledge and actual experience to enable them to work on electrical systems, understand any potential hazards related to the work under consideration, and recognise and avoid any risks involved.

Skilled qualified electrician for Ex areas

Skilled qualified electricians are individuals who have sufficient professional or technical training, knowledge and actual experience to enable them to work on electrical systems in areas with potentially explosive atmospheres, understand any potential hazards related to the work under consideration, and recognise and avoid any risks involved.

Skilled qualified electricians for Ex areas have special experience, and their training has included instruction on the various types of protection and installation practices and on the general principles of area classification. Evidence of the relevant experience and training claimed must be available.

They know the rules and regulations relevant to their work and to explosion protection, in particular the ATEX directive 2014/34/EU and the related standard EN 60079 as well as IEC Ex standard IEC 60079.



Working in areas with potentially explosive atmospheres

The system owner may require that work in areas with potentially explosive atmospheres is carried out by individuals with additional qualifications. Any work requires that the system owner has been informed and agreed to it.

2.3 Personal protective equipment

Description of personal protective equipment

Hearing protection



Hearing protection protects against hearing damage resulting from noise exposure.

Industrial safety helmet



Industrial safety helmets protect the head from falling objects, suspended loads, and the effects of striking the head against stationary objects.

Protective clothing



Protective clothing is close-fitting, with low tear resistance, close-fitting sleeves, and no projecting parts.

Protective gloves



Protective gloves protect hands from friction, abrasions, punctures, deep cuts, and direct contact with hot surfaces.

Safety harness



A safety harness protects people from a fall when they are working at height. You are at risk from a fall if the task is at height and if there is no railing in place.

When you put on a safety harness, connect it via an energy-absorbing lanyard to a suitable anchor point.

Safety harnesses must only be used by individuals who have been specifically trained to use them.

Safety shoes



Safety shoes protect the feet against crushing, falling parts, and from slipping on slippery ground.

Explosion protection

WARNING!

Explosion hazard from electrostatic charges!

If you have to work in areas with potentially explosive atmospheres, make sure that no electrostatic charge is built up on non-metallic parts and induced in your body.

To avoid electrostatic charges:

- Wear anti static clothes, shoes, gloves etc.
- For tools, comply with EN 1127-1, appendix A.

The work area should ideally have anti static flooring.

2.4 Residual risks

Suspended loads

DANGER!

Danger of death due to suspended loads!

Falling loads may cause serious injury or death.

Therefore:

- Never walk under suspended loads.
- Only move loads under supervision.
- Observe the specifications for the intended lashing points.
- Do not attach the lifting gear to protruding machine parts or lugs on attached components
- Ensure that the lifting gear is secure.
- Only use approved hoisting devices and lifting gear with sufficient load-bearing capacity.
- Do not use any frayed or worn ropes and belts.
- Do not place ropes or belts near sharp edges or corners; do not knot or twist.
- Place the load on the ground before leaving the workplace.

Industrial trucks

WARNING!

Danger to life from industrial trucks!

Objects and other loads could fall in an uncontrolled manner from industrial trucks during transport and cause serious injuries or even death. There is also the risk that people will not be seen and could thus be run over by the vehicle driver.

- Industrial trucks may only be operated by trained vehicle drivers (e.g. forklift drivers).
- People should only pass industrial trucks when the vehicle driver has signalled that they have seen them.
- Only approved industrial trucks with sufficient load-bearing capacity may be used.
- Materials should never be transported in the vicinity of people or the zones occupied by people.

Electric current

DANGER!

Danger of death due to electric current!

Danger of electric shock! Do not touch any live components! Damaged insulation or damaged parts are a life threatening hazard.

- Have work on the electrical system carried out only by skilled qualified electricians.
- Have work on the electrical system carried out only by skilled qualified electricians.
- If the insulation is damaged, disconnect the power supply immediately and have the insulation repaired.
- Before you start working on electric systems and equipment, switch off the supply voltage and secure it against being switched on accidentally. Comply with the 5 safety rules:
 - Disconnect.
 - Secure it against being switched on accidentally.
 - Ensure that no voltage is present.
 - Connect to the earth; short circuit connection.
 - Either cover nearby parts that carry a voltage or install barriers.
- Do not bypass or disable any circuit breakers. Be sure to maintain the correct current rating when you replace a circuit breaker.
- Ensure that live parts do not come into contact with moisture. Moisture can cause a short circuit.

Dirt and objects lying around

CAUTION!

Risk of injury from falling as a result of dirt or objects lying around!

Dirt and objects lying around can lead to the risk of slipping and tripping. Injuries can be caused by falling.

- Work areas should always be kept clean.
- Objects that are no longer required should be removed from the work area, particularly those that are near the floor.
- Tripping hazards that cannot be avoided should be marked with yellow and black marking tape.

Tools

CAUTION!

Risk of injury as a result of the negligent handling of tools!

Negligent handling of tools can lead to crushing or cuts.

- Tools must be handled carefully and as intended.
- The weight must be taken into account when transporting tools.
- Protective gloves and safety shoes should be worn.

Rotating parts

WARNING!

Risk of injury from rotating parts!

Rotating parts in the fan can cause serious injuries.

- Do not reach into or handle the moving impeller wheel during operation.
- Do not open inspection access doors and covers during operation.
- Ensure that the impeller wheel is not accessible during operation.
- Observe the run down time! Check that no parts are moving before you open an inspection access door or cover.
- Switch off the unit and secure it against being switched back on again before starting any work on moving fan components. Wait until all parts have come to a standstill.

Noise

WARNING!

Hearing damage due to noise!

The noise level in the work area can cause severe hearing damage.

- Always wear hearing protection while working.
- Only remain in the hazardous area if absolutely necessary.

Crushing hazard.

WARNING!

Crushing hazard from movable parts!

There is an increased risk of crushing on casing units, doors, panels and components of the device.

- Never reach between moving parts.
- Be careful when carrying out any work.
- Wear protective gloves, safety shoes and a hard hat.

Inspection access doors slamming shut

WARNING!

Risk of crushing from doors slamming shut

Inspection access doors may slam shut by the wind or if someone pushes them inadvertently, resulting in serious injury to the head and limbs.

- Secure each inspection access door with a hold open device.
- Secure inspection access doors without a hold open device against closing by suitable means.
- Do not reach between the door and door frame.
- Wear protective gloves and a hard hat when you open an inspection access door.

2.5 Behaviour in the event of hazardous situations or accidents

Preventative measures

- Always be prepared for accidents or fire!
- Keep first aid equipment (first aid kit, blankets, etc.) and fire extinguishers close at hand.
- Familiarise personnel with accident reporting, first aid and rescue equipment.
- Keep access paths for rescue vehicles clear.

Measures in the event of accidents

- Trigger an emergency stop immediately, and put the isolator into the “0” position if necessary.
- Implement first aid measures.
- Rescue individuals from the hazardous area.
- Inform the responsible person at the operation site.
- Notify the emergency services.
- Clear access paths for rescue vehicles.

Buy replacement parts from an authorised supplier or from the manufacturer. For contact details see page 2.

2.6 Replacement parts **WARNING!****Risk of injury from the use of incorrect replacement parts!**

Incorrect or faulty replacement parts pose a risk to health and safety, and their use can cause malfunction, damage to property and total failure of equipment.

- Use only genuine replacement parts from the manufacturer or replacement parts that the manufacturer has approved.
- When in doubt, contact the manufacturer.

 **Void of warranty**

Using non-approved replacement parts will void your product's warranty.

Buy replacement parts from an authorised supplier or from the manufacturer. For contact details see page 2.

Explosion protection **WARNING!****Risk of explosion from the use of incorrect replacement parts!**

Using incorrect or faulty replacement parts in areas with potentially explosive atmospheres may lead to an explosion. This can cause serious or even fatal injuries as well as considerable damage to property.

- Use only genuine replacement parts from the manufacturer or replacement parts that the manufacturer has approved.
- When in doubt, contact the manufacturer.

Failure to comply with these safety notes may lead to an explosion.

 **Void of warranty**

Using non-approved replacement parts will void your product's warranty.

3 Transport and storage

3.1 Delivery of the air handling unit

3.1.1 Complete and partial units

Upon delivery, check the air handling unit for transport damage and completeness, see *Chapter 3.2 'Delivery check' on page 12*.

Depending on its size, the air handling unit is shipped either fully assembled or in parts, with the individual components or casing units screw-fixed to square edge timber frames or disposable pallets.

The number of parts is shown on a drawing on the package.



External components may be shipped unassembled to protect them from getting entangled with transport slings while being moved. These components have to be properly installed and sealed by others.

3.1.2 Symbols on the packaging

The packaging carries the following marks and symbols. Be sure to follow them when you are moving the unit.



The packaging may also carry other symbols, notes, and information. These must also be followed.

Accessories



Fig. 2: Accessories

Packages with this sticker contain air handling unit accessories.

Lashing point

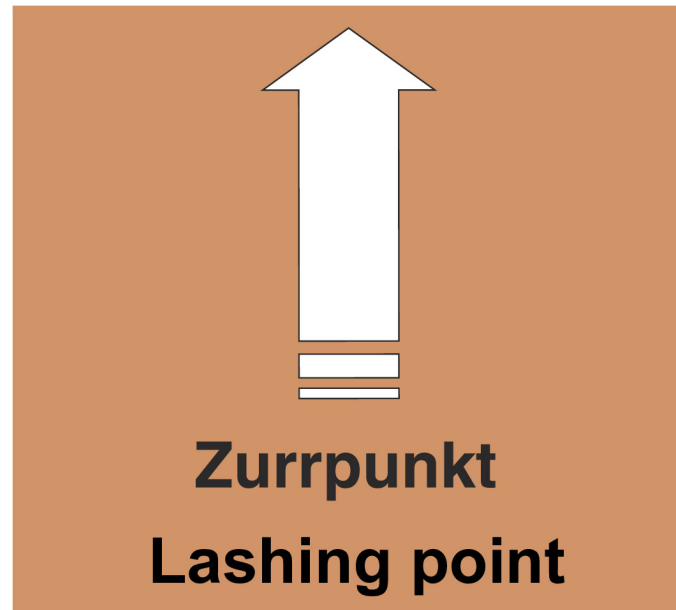

Fig. 3: Lashing point

This sticker indicates how to position a package for transport.

3.2 Delivery check

Check delivered items immediately after arrival for transport damage and completeness. In case of any damage or an incomplete shipment, contact the shipping company and your supplier immediately. If any parts are missing, have the driver confirm them on the consignment note.

Otherwise the manufacturer will not accept any liability.



See the notes on shipping damage on the packaging or in the shipping papers.

For any claims it is necessary that you follow the procedure below. In each of the following cases do contact TROX before you start installing a unit.

The packaging has been damaged

- Unpack the goods in the presence of the person who has delivered the goods and have them confirm the damage on the shipping order.
- Photograph the damage.
- Report the damage to TROX immediately.

No external damage to packaging, contents damaged.

- Photograph the damage.
- Report the damage to TROX immediately in writing.
- Note that shipping damage must be reported within four days of delivery.

Explosion protection **WARNING!****Risk of explosion from parts damaged while in transit!**

Goods damaged while in transit are unsuitable for use in potentially explosive atmospheres.

- If upon delivery any damage is visible, inform the manufacturer. Do not commission the unit.
- If upon delivery any damage is visible, inform the manufacturer. Do not commission the unit.
- If upon delivery any damage is visible, inform the manufacturer. Do not commission the unit.
- If upon delivery any damage is visible, inform the manufacturer. Do not commission the unit.

Failure to comply with these safety notes may lead to an explosion.

3.3 Moving packages**3.3.1 Safety notes regarding transport****Explosion protection** **WARNING!****Risk of explosion!**

Ignition sources, such as sparks, open flames or hot surfaces, can lead to explosions in an area with potentially explosive atmospheres.

- Only specially trained personnel must carry out work in an area with potentially explosive atmospheres.
- Get written permission before you start working in an area with potentially explosive atmospheres.
- If you have to carry out work, either ensure that there is no potentially explosive atmosphere, or at least avoid any source of ignition. If you have to work in a zone with potentially explosive atmospheres, use only equipment that has been approved for use in that particular zone.

Failure to comply with these safety notes may lead to an explosion.

Improper transport equipment **WARNING!****Risk to life from using improper transport equipment!**

If packages are lifted without adequate transport equipment and if they are not properly secured, they may fall off and lead to fatal injuries.

- Move components only in the position in which they are to be installed.
- Stand clear of suspended loads.
- Do not move additional loads on top of a package.
- Use only the intended lashing points.
- Make sure that no load is imposed on pipes, ducts or cables.
- Use only approved lifting gear and slings that are suitable and sufficient for the load to be carried.
- Do not tie ropes and chains or make knots or place them on sharp edges.
- Use lifting equipment only to lift packages or units, not to push or pull them.
- Ensure that ropes, belts and chains do not twist.
- Ensure that transport equipment has been correctly assembled, fastened and secured before you use it to lift anything.
- Secure all doors, dampers and panels.
- Move packages without any jerky movements and put them down when you leave your workplace.
- Lifting eyes are designed for one-time use only and not for permanently suspending loads.
- Transport tubes are designed for one-time use only and not for permanently suspending loads.

👉 2.4 'Residual risks' on page 9

Warning: AHU casing units may tip over



! WARNING!

Risk of injury from AHU casing units tipping over!

Tall AHU casing units with a small footprint, e.g. rotary heat exchangers, may easily tip over and therefore pose an increased risk during unloading, transportation and installation.

Be sure to take adequate precautions:

- Use additional means to secure the casing units, e.g. ratchet straps (by others).
- Use only lifting and transport gear designed for the required load.
- Keep the casing units secured against shifting and tipping over until installation is complete.

Unbalanced loads and centre of gravity

! WARNING!

Risk of injury from falling or toppling loads!

Loads may be unbalanced, i.e. the centre of gravity may not be obvious. If the load is not properly attached to the lifting equipment, it may topple and fall. Falling or toppling loads can cause serious injuries.

- Note that the centre of gravity is marked on each package.
- When you use a crane to move loads, ensure that the centre of gravity of the load is directly beneath the crane hook.
- Lift any load carefully and keep an eye on it to see whether it will stay in place. If required, change the lashing point(s).

Sticker indicating the centre of gravity

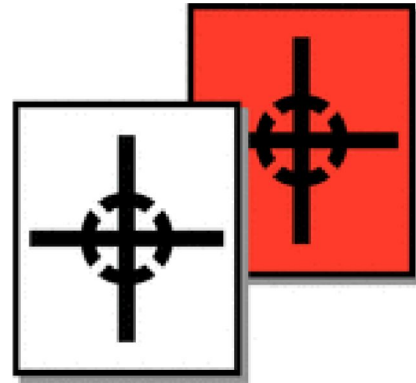

Fig. 4: Shipping stickers

Stickers on the packaging indicate the centre of gravity (Fig. 4).

Sharp edges, sharp corners and thin sheet metal parts

! CAUTION!

Danger of injury from sharp edges, sharp corners and thin sheet metal parts!

Sharp edges, sharp corners and thin sheet metal parts of the heat exchanger or of the cooling or heating coil may cause cuts or grazes.

- Be careful when working on these components.
- Wear protective gloves, safety shoes and a hard hat.

Damage to goods being moved

! NOTICE!

Risk of damage to property due to the incorrect handling or lifting of units!

If you handle or move packages incorrectly, they may topple or fall. This can cause considerable damage to property.

- Do not put down packages hard and do not knock against them with force. Watch out for protruding parts.
- When you are moving units for outdoor installation, be careful that the thin metal roof is not damaged by the lifting gear.

3.3.2 Moving packages with a forklift or pallet truck

Air handling units differ in weight and may have different lashing points. See the order-specific technical documents for details.

Personnel:

- Forklift driver

Protective equipment:

- Industrial safety helmet
- Protective clothing
- Protective gloves
- Safety shoes

! NOTICE!

Risk of damage to property from forklifts or pallet trucks!

Take proper precautions when you use a forklift or pallet truck to move or lift parts or components of an air handling unit as otherwise they may be damaged.

- If you want to use a forklift to lift a package without a base frame, you need to protect the casing units properly.

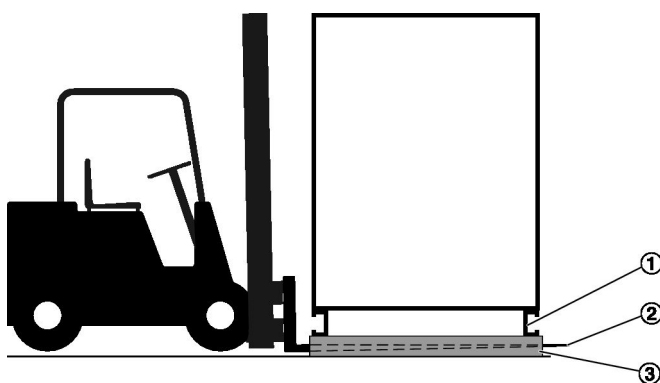

Fig. 5: Carrying load with a forklift

1. ▶ Drive the forklift forward until the forks (Fig. 5 /3) are fully between the square edge timber sections (Fig. 5 /2) and protrude from underneath the base frame (Fig. 5 /1) on the opposite side.
2. ▶ Ensure that the load cannot tip.
3. ▶ Slowly lift the load and start moving.

3.3.3 Moving packages with a crane

Lashing points

The AHU casing units have lashing points for crane transport. Depending on the construction and weight of a unit, lashing points are:

- Lifting eyes ☞ 16
- Eye nuts ☞ 17
- Transport tubes ☞ 18

The lashing points are part of the supply package. Use only the factory lashing points to move AHU casing units. If a unit has to be moved with different equipment, contact TROX beforehand to discuss the details.

Transport straps

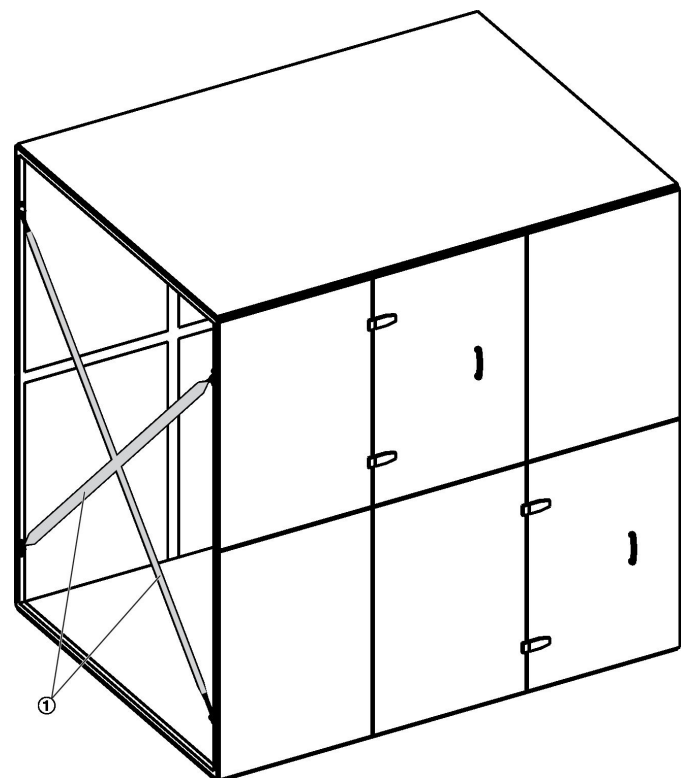

Fig. 6: Straps

AHU casing units which are more than 2448 mm wide are factory fitted with transport straps (Fig. 6 /1) that give them extra stability for transport. Always move AHU casing units with the transport straps or other transport protection device in place; remove straps or transport protection devices only when the unit has reached its final position.

Using lifting eyes

Personnel:

- Crane driver

Protective equipment:

- Industrial safety helmet
- Protective clothing
- Protective gloves
- Safety shoes

WARNING!

Danger of death from the fall of AHU casing units.

If you overload lashing points or lifting gear, the load may fall down. You or others could be killed.

- Use lifting eyes only to move AHU casing units up to a maximum weight of 1500 kg.
- Use all the lashing points provided.
- Use only adequate lifting gear and slings.
- Stand clear of suspended loads.

- Maintain an angle greater than 45° between the sling and the top of the unit.
- Do not spread slings by more than 60°.
- Ensure that the slings cannot damage the AHU casing unit.
- Suspend (distribute) the load symmetrically, i.e. in such a way that its centre of gravity is beneath the crane hook.



We recommend using a chain hoist and spreader beam in the following cases:

- If the correct angles for the slings cannot be maintained.
- If there are more than four lashing points on a package.

4. ▶ Slowly lift the load and start moving.

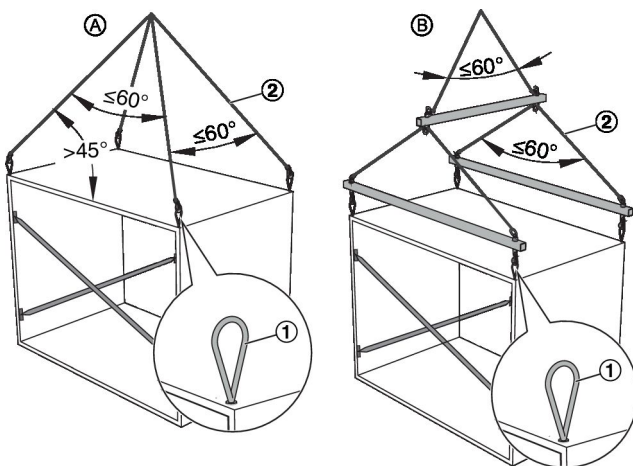

Fig. 7: Using lifting eyes for moving units with a crane

AHU casing unit maximum weight: 1500 kg

- (A) Moving units with ropes/chains
- (B) Moving units with a spreader beam
- (1) Lifting eye
- (2) Slings

1. ▶ Remove the covers from the threaded holes in the top corners of the AHU casing unit.
2. ▶ Insert all lifting eyes (Fig. 7 /1) completely into the threaded holes.



Several lifting eyes are part of the supply package; if you have used them for moving other AHU casing units, you can reuse them.

3. ▶ Hook the slings (Fig. 7 /2) into the lifting eyes.

Note:

Using eye nuts

Personnel:

- Crane driver

Protective equipment:

- Industrial safety helmet
- Protective clothing
- Protective gloves
- Safety shoes



WARNING!

Danger of death from the fall of AHU casing units.

If you overload lashing points or lifting gear, the load may fall down. You or others could be killed.

- Use eye nuts only to move AHU casing units up to a maximum weight of 1000 kg.
- Use all the lashing points provided.
- Use only adequate lifting gear and slings.
- Stand clear of suspended loads.

- Suspend (distribute) the load symmetrically, i.e. in such a way that its centre of gravity is beneath the crane hook.



We recommend using a chain hoist and lifting beam in the following cases:

- *If the correct angles for the slings cannot be maintained.*
- *If there are more than four lashing points on a package.*

- ▶ Slowly lift the load and start moving.

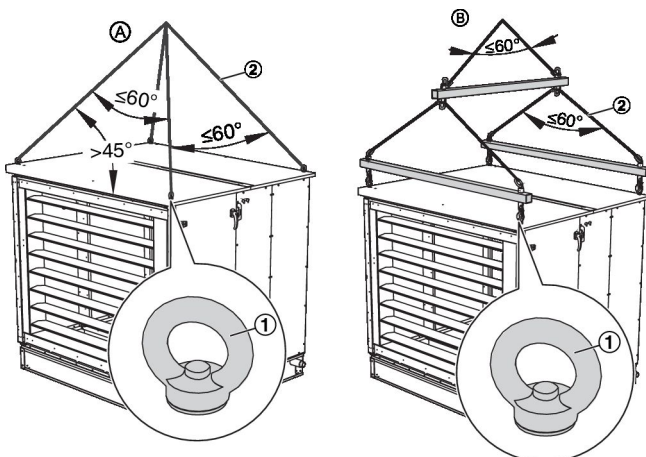

Fig. 8: Using eye nuts for moving units with a crane

AHU casing unit maximum weight: 1000 kg

- (A) Moving units with ropes/chains
- (B) Moving units with a lifting beam
- (1) Eye nut
- (2) Slings

- ▶



AHU casing units with a roof are factory fitted with eye nuts.

Hook the slings (Fig. 8 /2) into the eye nuts.

Note:

- Maintain an angle greater than 45° between the sling and the top of the unit.
- Do not spread slings by more than 60° .
- Ensure that the slings cannot damage the AHU casing unit.

Using transport tubes

AHU casings or casing units that cannot be moved using lifting eyes or eye nuts have to be moved with transport tubes. Transport tubes are part of the supply package. If several AHU units are to be moved, you will have to reuse the transport tubes.

If you have to move AHU casing units at a later stage and do not have the original transport tubes any more, you may use other tubes with the following properties:

Seamless steel tube, S235JR+AR (St 37-2, EN 10025), wall thickness of 5 mm.

Select the right transport tubes for the casing unit weight and width using the tables below.

Diameter of the transport tubes

Outer diameter [mm]	Weight of AHU casing unit [kg]	
	Europe	United Kingdom
48.3	≤ 1500	≤ 960
60.3	≤ 2000	≤ 1590
76.1	≤ 3000	≤ 2650

Weights apply to two transport tubes.

Use more tubes for higher component weights.

Length of the transport tubes

Width of AHU casing unit (inside dimension) [mm]	Length of transport tubes [mm]
612	1058
918	1364
1224	1670
1530	1976
1836	2282
2142	2588
2448	2894
2754	3200
3060	3506
3366	3812
3672	4118
3978	4424
4284	4730
4590	5036
4896	5342

Personnel:

- Crane driver

Protective equipment:

- Industrial safety helmet
- Protective clothing
- Safety shoes
- Protective gloves

 **WARNING!**

Danger of death from the fall of AHU casing units.

If you overload lashing points or lifting gear, the load may fall down. You or others could be killed.

- When you use transport tubes, be sure to use tubes with the correct diameter for the weight to be moved
↳ 'Using transport tubes' on page 18 .
- Use all the lashing points provided.
- Use only adequate lifting gear and slings.
- Stand clear of suspended loads.

The number of drilled holes in the base frame (Fig. 9 /6) indicates the number of transport tubes (Fig. 9 /1) to be used.

- Select the lashing points based on the number of transport tubes you use, Fig. 9

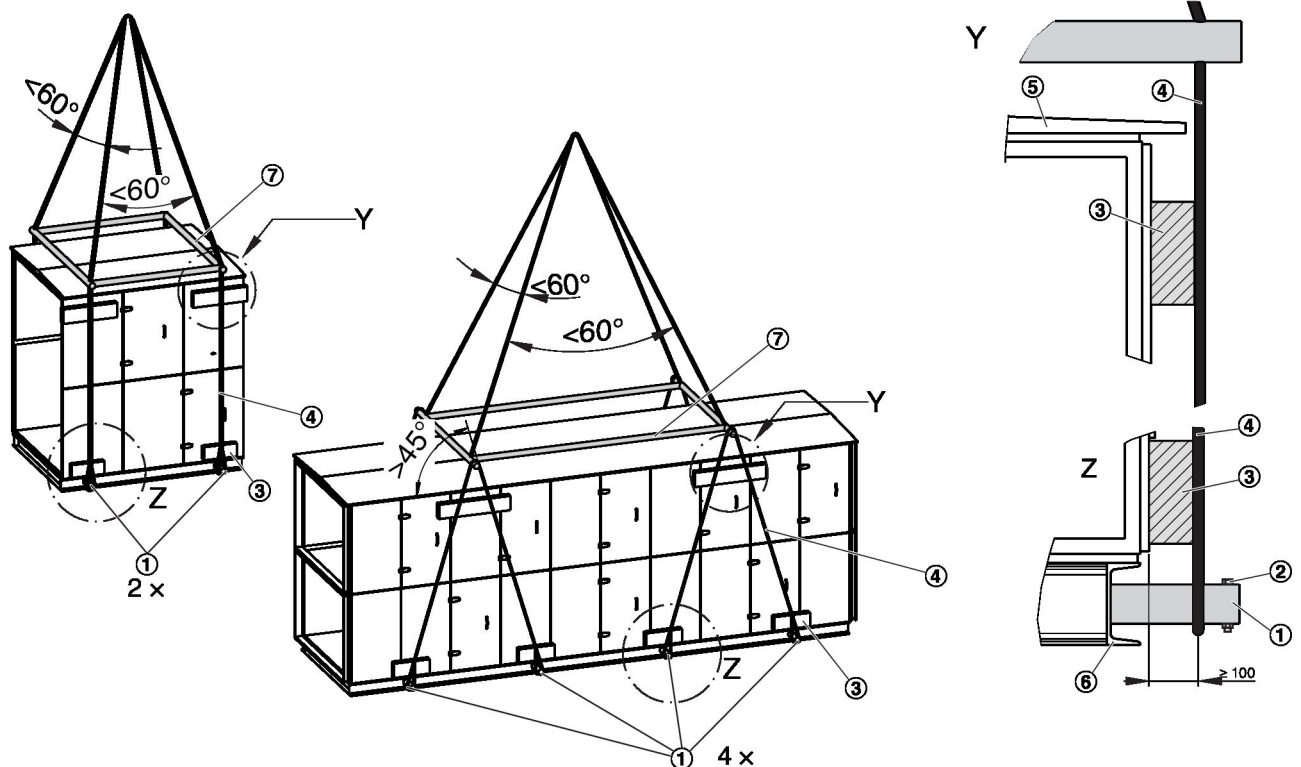

Fig. 9: Lashing points with two or four transport tubes

1. ▶ Remove the plugs from the drilled holes in the base frame (Fig. 9 /6) of the AHU casing unit.
2. ▶ Push transport tubes (Fig. 9 /1) through the drilled holes in the base frame.
Secure the transport tubes with screws (Fig. 9 /2).

3. ▶ Place the slings (Fig. 9 /4) around the ends of the transport tubes.

Position slings between the base frame (Fig. 9 /6) and the screws (Fig. 9 /2).

Protect the edges with wood blocks (Fig. 9 /3). If a unit with a roof (Fig. 9 /5) is to be moved, use wood blocks that are thick enough to provide a distance of 100 mm between the sling and the casing unit.

Spread the slings near the roof with a suitable device (Fig. 9 /7), e.g. a lifting beam.

Note:

- Do not spread slings by more than 60°.
- Ensure that the slings cannot damage the AHU casing unit.
- Suspend (distribute) the load symmetrically, i.e. in such a way that its centre of gravity is beneath the crane hook.

! NOTICE!

Risk of damage to property due to the incorrect handling or lifting of units!

Take proper precautions when you use a crane to move or lift parts or components of an air handling unit as otherwise they may be damaged.

- Protect the edges of the AHU casing units with wood blocks.
- Spread the slings (wire ropes or chains) near the roof with a suitable device, e.g. a lifting beam.

4. ▶ Slowly lift the load and start moving.

3.4 Storing packages

! NOTICE!

Risk of damage to property due to corrosion!

Insufficient ventilation due to film packaging can result in condensation and, hence, oxidation on galvanised surfaces, e.g. white rust.

- Remove film packaging immediately after delivery.
- Store all units in a dry, well-ventilated place.

In the case of Sendzimir-galvanised units, corrosion may occur on the cut edges. Reddish or whitish discolouration of the cut edge does not indicate problematic corrosion. Corrosion protection is still guaranteed. This does not indicate a reduction in quality and there are no grounds for complaint.

- The storage location must be level and have sufficient load-bearing capacity.
- If storing the units for more than 3 months, refer to the information on functional integrity, .

Note!

If there are storage instructions on the packaging, these instructions must be followed as well.

3.5 Unpacking

Unless packaging or the contents have been damaged while in transit, remove the packaging only when you are ready to start installation ↪ 3.2 'Delivery check' on page 12 .

Please note the following storage conditions:

- Do not store outdoors.
- Store in a dry and dust-free place that is not exposed to sunlight.
- Storage temperature: -10 °C to +50 °C; avoid sudden/major fluctuations in temperature.
- Provide unpackaged units with protective packaging and ensure sufficient ventilation in order to prevent condensation.
- Seal openings in the units to ensure that no dust or vermin can get inside.
- Do not expose the units to aggressive operating fluids.

**ENVIRONMENT!****Note on disposing of single-use packaging**

The packaging is purely transport packaging, which has been reduced to the absolute minimum with regard to transport and unloading.

Packaging materials can, in many cases, be reconditioned and recycled.

- Dispose of packaging materials in an environmentally friendly manner in accordance with the local waste disposal regulations.
- If necessary, employ a specialist disposal company to dispose of the packaging.

4 Setup and assembly

If an air handling unit is shipped in several parts, you have to erect and assemble it on site. The arrangement of the AHU casing units is given on the order-specific approval drawing.

Explosion protection

WARNING!

Risk of explosion from incorrect setup or assembly!

Incorrect setup or assembly of the air handling unit may lead to an explosion.

- Set up the AHU only in an Ex zone for which it has been approved; see the rating plate for details.
- Be sure to include the AHU in the explosion protection strategy for the entire system.
- Any electrical or mechanical components or devices to be installed or used in the AHU have to be approved for at least the same Ex zone. Due to normal leakage, an explosive atmosphere may escape from the inside of an AHU to the surrounding area (zonal dispersion). If the zone inside the AHU is more hazardous than in the surrounding installation room, any electrical or mechanical components or devices to be installed or used within a radius of 1 m (sometimes more) around the AHU have to be approved for the same zone as the inside of the AHU.
- Be careful not to damage any factory fitted equipotential bonding equipment, and do not remove it. If you have to remove any of it for assembly, be sure to fix it again properly afterwards.
- Connect components and devices installed by others to the equipotential bond.
- Ensure that duct and pipe insulation materials in the Ex zone do not lead to a build up of electrostatic charges as these may lead to an explosion.
- Comply with the code of good practice for explosion protection when you assemble the unit.

Failure to comply with these safety notes may lead to an explosion.

Conformity assessment

If components or devices which cannot in themselves perform a specific application (partly completed machinery) are incorporated into fully functional machinery, the individual who performs the incorporation or assembly is responsible for the conformity assessment, for creating the declaration of conformity and for attaching the CE mark.

4.1 Safety instructions

Explosion protection

WARNING!

Risk of explosion!

Ignition sources, such as sparks, open flames or hot surfaces, can lead to explosions in an area with potentially explosive atmospheres.

- Only specially trained personnel must carry out work in an area with potentially explosive atmospheres.
- Get written permission before you start working in an area with potentially explosive atmospheres.
- If you have to carry out work, either ensure that there is no potentially explosive atmosphere, or at least avoid any source of ignition. If you have to work in a zone with potentially explosive atmospheres, use only equipment that has been approved for use in that particular zone.

Failure to comply with these safety notes may lead to an explosion.

Setup and assembly

WARNING!

Risk to life from incorrect setup and assembly!

The incorrect setup and assembly of AHU casing units can lead to potentially fatal situations and cause considerable damage to property. Incorrect setup and assembly will also impair the function of the unit.

- Air handling units must only be set up and assembled by HVAC technicians.

Working at height **WARNING!****Risk of a fall when you work at height!**

Working at height without using any fall protection equipment, or using unsuitable or damaged equipment to get up to where you work at height, may lead to yourself or others falling from height; people on the ground may be at risk from falling parts or tools. This can cause serious or even fatal injuries.

- Only use equipment that is suitable, stable and strong enough for the job, maintained and checked regularly.
- Stop materials or objects from falling.
- Wear safety shoes, protective clothing and a hard hat.
- Wear a safety harness.

Interconnecting units and systems **WARNING!****Risk of injury from interconnecting different units or systems!**

Connecting an air handling unit to other units or systems (e.g. ductwork, pumps, refrigeration systems) can lead to dangerous situations and eventually cause serious or even fatal injuries.

- If you have to connect other units or systems to the air handling unit, connect them professionally.
- The system owner/HVAC contractor is responsible for the planning and installation of any additional safeguards.

Sharp edges, sharp corners and thin sheet metal parts **CAUTION!****Danger of injury from sharp edges, sharp corners and thin sheet metal parts!**

Sharp edges, sharp corners and thin sheet metal parts of the heat exchanger or of the cooling or heating coil may cause cuts or grazes.

- Be careful when working on these components.
- Wear protective gloves, safety shoes and a hard hat.

Crushing hazard. **WARNING!****Crushing hazard from movable parts!**

There is an increased risk of crushing on casing units, doors, panels and components of the device.

- Never reach between moving parts.
- Be careful when carrying out any work.
- Wear protective gloves, safety shoes and a hard hat.

Inspection access doors slamming shut **WARNING!****Risk of crushing from doors slamming shut**

Inspection access doors may slam shut by the wind or if someone pushes them inadvertently, resulting in serious injury to the head and limbs.

- Secure each inspection access door with a hold open device.
- Secure inspection access doors without a hold open device against closing by suitable means.
- Do not reach between the door and door frame.
- Wear protective gloves and a hard hat when you open an inspection access door.

4.2 Installation location, requirements**4.2.1 Requirements for indoor installation****Installation room**

Air handling units designed for indoor installation have to be installed in a room that meets the following requirements:

- The room has been designed in compliance with the applicable building regulations and is suitable for the technical systems to be installed. National standards for plant rooms may also apply.
- The installation room has to be
 - clean
 - dry
 - free from conductive dust particles
 - free from strong electromagnetic fields
 - free from aggressive atmospheres
 - free from frost
 - fitted with a functioning drainage system
- There is sufficient clearance for installing, operating, servicing, and repairing the AHU and all its parts.
 - The maintenance access has to be at least as deep as the unit.
 - The maintenance access must be wide enough so that all inspection access doors can be opened with an opening angle of 90°.

- The structure on which the air handling unit is to be installed must be suitable for the weight and have a level surface (see the order-specific data sheet for the air handling unit).
- Do not use the air handling unit as a structural element or as a roof for a building.

Explosion protection

WARNING!

Explosion hazard from leaking explosive atmospheres!

If the space in which the air handling unit is installed has not been defined as an Ex zone, you have to provide sufficient ventilation as otherwise an explosive atmosphere may result due to leakages.

Escaping water

NOTICE!

Risk of damage to property from escaping water!

If the water system is not tight, water may escape and cause considerable damage to property.

- Ensure that liquids are channelled away and to a collection device.

Installation room foundation

The installation room foundation must fulfil the following requirements:

- It is horizontal, flat and robust, made of concrete; alternatively, a supporting structure made of steel may be used.
- The frequency of the supporting structure, particularly of a steel structure, is sufficiently different from the excitation frequency of movable components, such as fans, motors, pumps or refrigerant condensers.
- For air handling units with a condensate drain, the supporting structure is at least as high as the drain trap, see  *Chapter 5.3 'Sizing and connecting the condensate drain' on page 34*
- If additionally structure-borne noise is to be attenuated (e.g. by rubber or elastomer sheets underneath the air handling unit), be sure to exactly align all AHU casing units (check for door closure, properly sealed joints).

4.2.2 Requirements for outdoor installation

Installation location

For outdoor installation please note:

- The installation location has to be
 - free from conductive dust particles
 - free from strong electromagnetic fields
 - free from aggressive atmospheres
 - fitted with a functioning drainage system
- The structure on which the air handling unit is to be installed must be suitable for the weight and have a level surface (see the order-specific data sheet for the air handling unit).
- There is sufficient clearance for installing, operating, servicing, and repairing the AHU and all its parts. The maintenance access has to be at least as deep as the unit.
- Make sure that the installation location meets local regulations to prevent the fall of people, and of tools and other objects.
- Use suitable fall arrest equipment.
- Prevent unauthorised individuals from accessing AHU casing units.
- Make sure that authorised individuals can access AHU casing units safely.
- Keep the structural properties in mind and make sure the maximum roof load is not exceeded; do not neglect the effects of weather on the unit (rain, snow, wind, sun etc.).
- Only a skilled qualified professional must connect the air handling unit to an external switch cabinet and prevent the cables from the effects of weather (rain, snow, wind, sun etc.).
- All operating fluid pipes and hoses and the AHU components to which they are connected must be frost-proof.
- Do not use the air handling unit as a structural element or as a roof for a building.

Foundation of the outdoor installation area

- The information regarding the foundation of the installation room applies,  *'Installation room foundation' on page 24*
- For roof installation, check the load capacity and support structure of the roof; consult an engineer if necessary
- The entire air handling unit must be supported by a continuous steel structure.
- The steel girders must be designed for a maximum deflection of L/500 under load (L = girder length). A maximum deflection of 10 mm under load must not be exceeded
- Waterproof the edge of the roof under the air handling unit and also any connections penetrating the roof.
- Insulate the plinth structure (by others) to prevent condensation.
- In areas with heavy snowfall, choose an installation location where snow will not affect the operation of the air handling unit. Make sure that the supporting structure is high enough.

Escaping water

! NOTICE!

Risk of damage to property from escaping water!

If the water system is not tight, water may escape and cause considerable damage to property.

- Ensure that liquids are channelled away and to a collection device.

4.3 Preventing vibration and structure-borne noise

Anti-vibration elements or a noise insulating layer underneath the air handling unit may help to reduce the transmission of vibration from the air handling unit to the supporting structure:

- If the air handling unit is to be installed on level ground with no special requirements regarding structure-borne noise insulation, we recommend placing rubber or elastomer sheets between the air handling unit and the foundation.
- For noise insulation, compare the requirement to the sound power level of the air handling unit (see order-specific data sheet for the air handling unit) and have the necessary measures determined by an acoustics engineer.

! NOTICE!

Risk of damage to the AHU

Anti-vibration elements or a noise insulating layer must not affect the structural safety of the AHU. Ensure the following:

- Use a sufficient number of anti-vibration elements and noise insulating layers and place them correctly as otherwise the frame may sag.
- Keep in mind that the various AHU casing units differ in weight; this must not lead to any height differences in the overall unit.

We recommend you to have noise insulating layers (including material and layout plan) selected and sized by an expert company.

4.4 Setting up and assembling the air handling unit

Personnel:

- HVAC technician

Protective equipment:

- Industrial safety helmet
- Hearing protection
- Protective clothing
- Protective gloves
- Safety shoes

- Safety harness

4.4.1 Setting up the AHU or AHU casing units

Checking the seals on AHU casing units

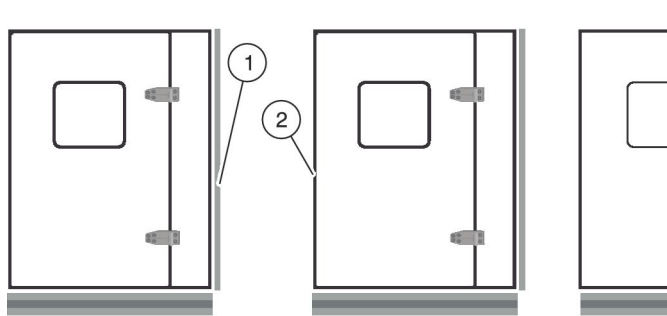

Fig. 10: Seals on AHU casing units

Where two AHU casing units are to be joined, a perimeter seal (Fig. 10 /1) is provided. Note that only one of the units to be joined is fitted with a seal. The other unit does not have a seal (Fig. 10 /2).



Compressed seals will recover fully to their original state about 60 minutes after the transport protection devices have been removed.

Check that the seals are complete and intact and that they seal properly.

Setting up AHU casing units

Slide plates (Fig. 11 /3) considerably simplify the process of positioning the AHU casing units (Fig. 11 /1) on a surface with a high friction coefficient, such as rubber or elastomer sheets (Fig. 11 /4).



The arrangement of the AHU casing units is given in the order-specific approval drawing.

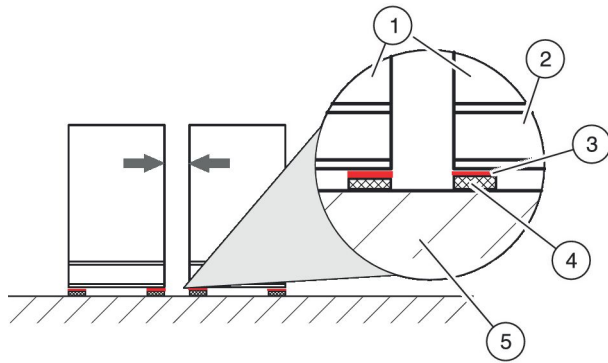

Fig. 11: Unit arrangement with anti vibration elements

1. ▶ Position the slide plates (Fig. 11 /3, by others) under the base frames (Fig. 11 /2) of the AHU casing units (Fig. 11 /1).
2. ▶ Move the AHU casing units as close together as possible.

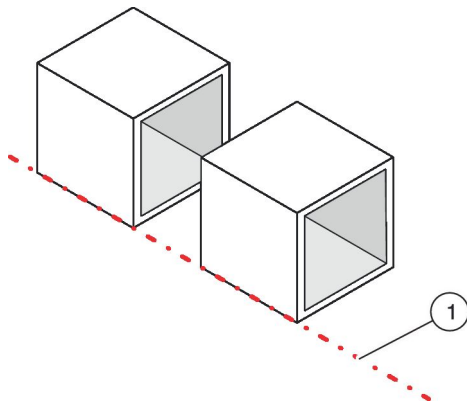

Fig. 12: Aligning AHU casing units

3. ▶ Align the AHU casing units so that they are flush with one another (Fig. 12 /1).

Setting up units with a base frame

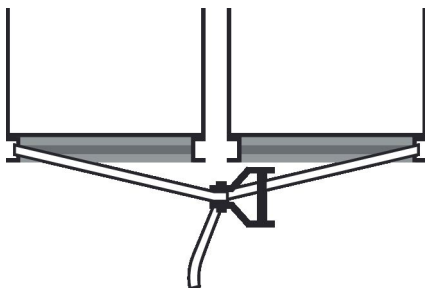

Fig. 13: Attaching a ratchet strap

1. ▶ Attach a ratchet strap to the base frames of two AHU casing units (Fig. 13).
2. ▶ Tighten the ratchet strap.

⇒ The AHU casing units come closer together as you tighten the strap around the base frames.

Alternatively:

Setting up units without a base frame

1. ▶ Attach a ratchet strap to the bottom or top areas of two AHU casing units.
2. ▶ Tighten the ratchet strap.
 - ⇒ The AHU casing units come closer together as you tighten the strap.

4.4.2 Assembling AHU casing units

Before assembly

- Remove all transport tubes and transport protection devices from the AHU casing units.
- Have all the required tools ready.
- Have all the applicable documents at hand.
- Remove all separately supplied materials and accessories from the AHU casing units.



Compressed seals will recover fully to their original state about 60 minutes after the transport protection devices have been removed.

Joining AHU casing units with screws/bolts

! NOTICE!

Risk of damage to property from incorrect assembly!

Be sure to assemble the AHU casing units correctly as otherwise the condensate drain may be damaged.

- Protect the condensate drain from damage.

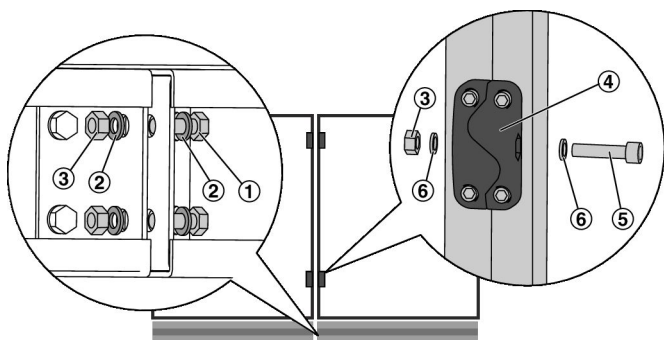

Fig. 14: Joining the base frames with screws/bolts

- ① Hexagon head screws
- ② Washers
- ③ Nuts
- ④ Module connectors
- ⑤ Allen screws
- ⑥ Schnorr® washers

- ▶ Use screws/bolts to join the casing units at the base frame and at the module connectors.

EX WARNING!

Risk of explosion!

Improper assembly may lead to an explosion! The joints between individual AHU casing units provide equipotential bonding.

- Position all Schnorr® washers as described.
- Secure all screw joints.

Failure to comply with these safety notes may lead to an explosion.

Assembly steps:

- Put the individual AHU casing units into the correct position for assembly and assemble them.
- Remove the front part of the casing unit into which the plate heat exchanger is to be installed (operating side). In the case of subdivided casings also remove the tubular frame on the operating side of the casing unit into which the plate heat exchanger is to be installed.
- Assemble the plate heat exchanger outside of the AHU and according to the manufacturer's instructions ↪ *Appendix A.3 'Hoval' on page 123*.
- Push the completely assembled plate heat exchanger into the AHU casing; be sure to position it correctly with regard to the bypass damper and recirculation damper (if any) ↪ Approval drawing (included with the technical data sheets).
- Mount the sealing sheets.
- Assemble the frame parts and panel by following the steps in reverse order.

Plate heat exchanger

If the plate heat exchanger is delivered in several parts, it has to be assembled and installed in the AHU casing by others.

Fitting flexible connectors

If flexible connectors have been supplied separately, install them once the AHU units have been set up and assembled. Depending on the AHU construction variant the flexible connectors have to be attached to the AHU casing, to the base frame or to a multileaf damper.

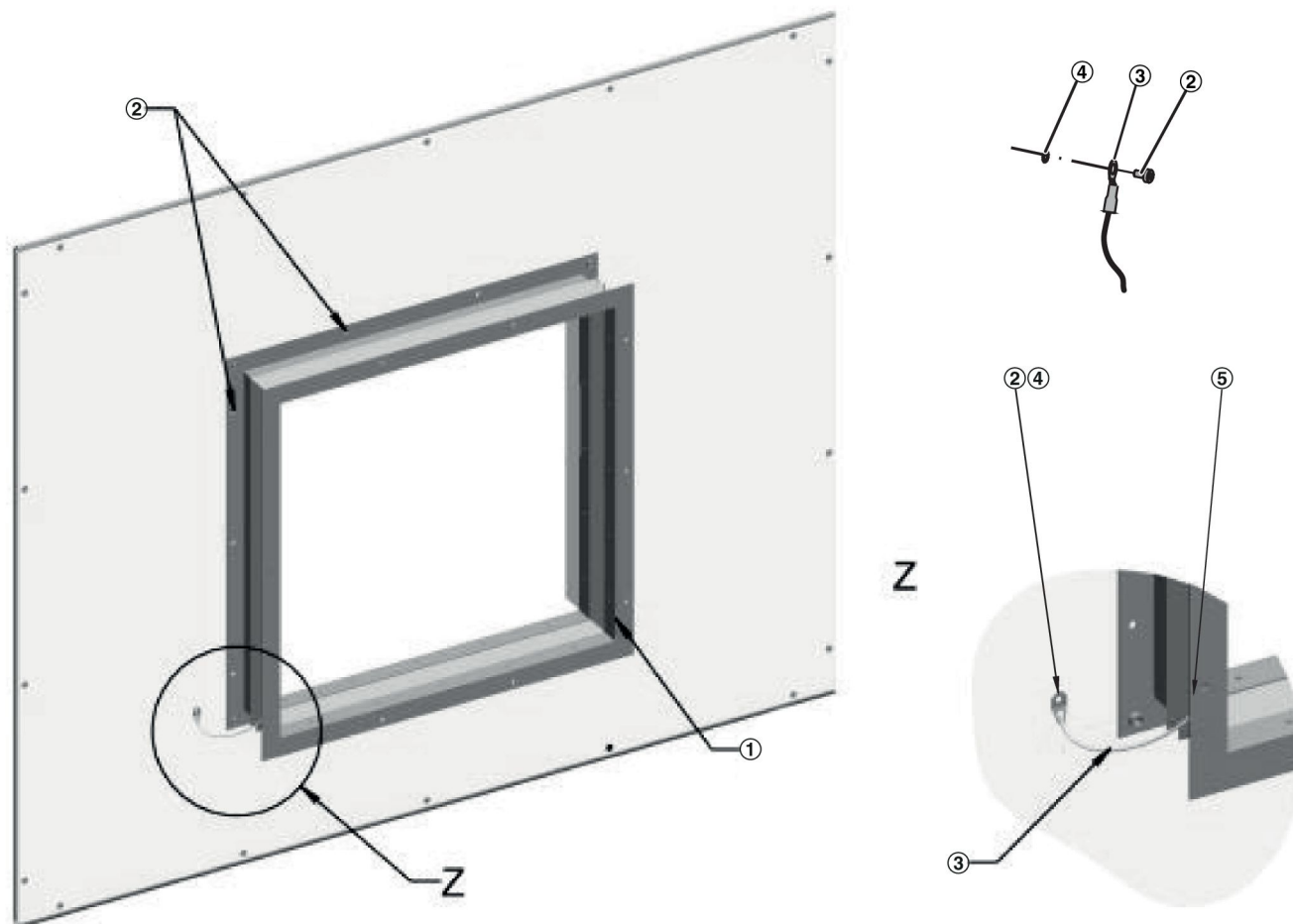

Fig. 15: Flexible connector

Item	Meaning	Part no.
①	Flexible connector	
②	Thread forming pan head screw	M852AC6
③	Ground cable	
④	Schnorr washer	A00000055655
⑤	Secure all screw joints.	By others

1. ▶ Fix the flexible connector (Fig. 15 /1) with screws (Fig. 15 /2) to the AHU.
2. ▶ Fix one eye of the ground cable (Fig. 15 /3) with a screw (Fig. 15 /2) and a Schnorr washer (Fig. 15 /4) to the panel of the AHU. Fix the other eye of the ground cable to the duct (conductive) and secure it (Fig. 15 /5).

4.4.3 Additional assembly steps for outdoor units

Roof segments

Air handling units for outdoor installation require the following additional assembly steps:

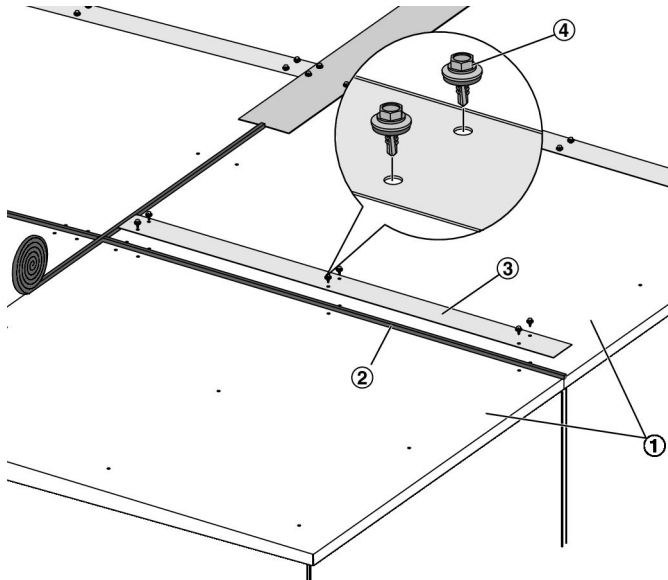

Fig. 16: Joining roof segments

- 1 Roof segments
 - 2 Self-adhesive joint sealing tape
 - 3 Cover strips
 - 4 Self-drilling screws with sealing washers
1. ▶ Seal all joints between the roof segments (Fig. 16 /1) with self-adhesive joint sealing tape (Fig. 16 /2). Follow the tape manufacturer's instructions for use. Attach the cover strips (Fig. 16 /3) and fix them with self-drilling screws (Fig. 16 /4).

! NOTICE!

Remove the eye nuts where the casing units are to be joined so that you can actually join the roof segments. Do not remove the other eye nuts; they have to remain in place to prevent the ingress of rain into the unit.

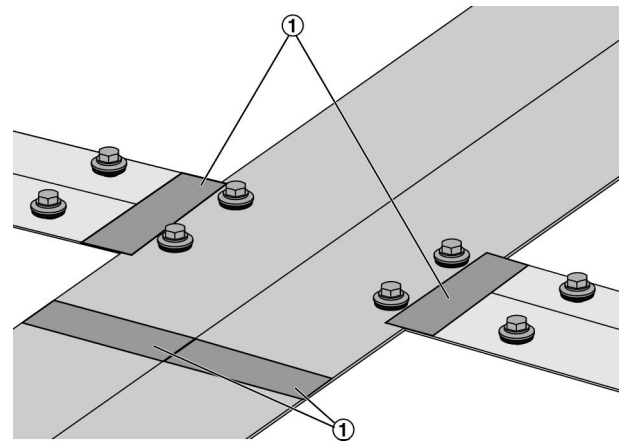

Fig. 17: Sealing the joints

2. ▶ Seal the joints (Fig. 17 /1) between the cover strips with self-adhesive sealing tape (butyl tape). Follow the tape manufacturer's instructions for use.

Stacked units (step design)

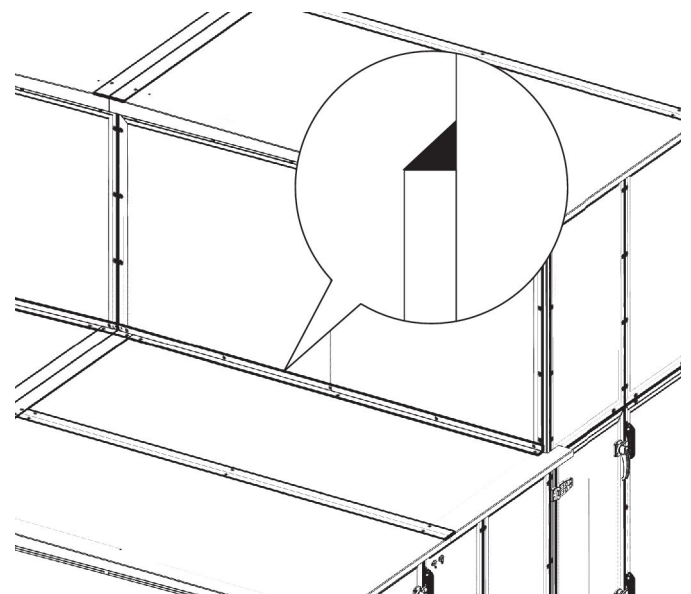

Fig. 18: Step design

3. ▶ Fix the connecting angle section for the roof segment with self-drilling screws and seal it with sealant.

Attaching the weather hood

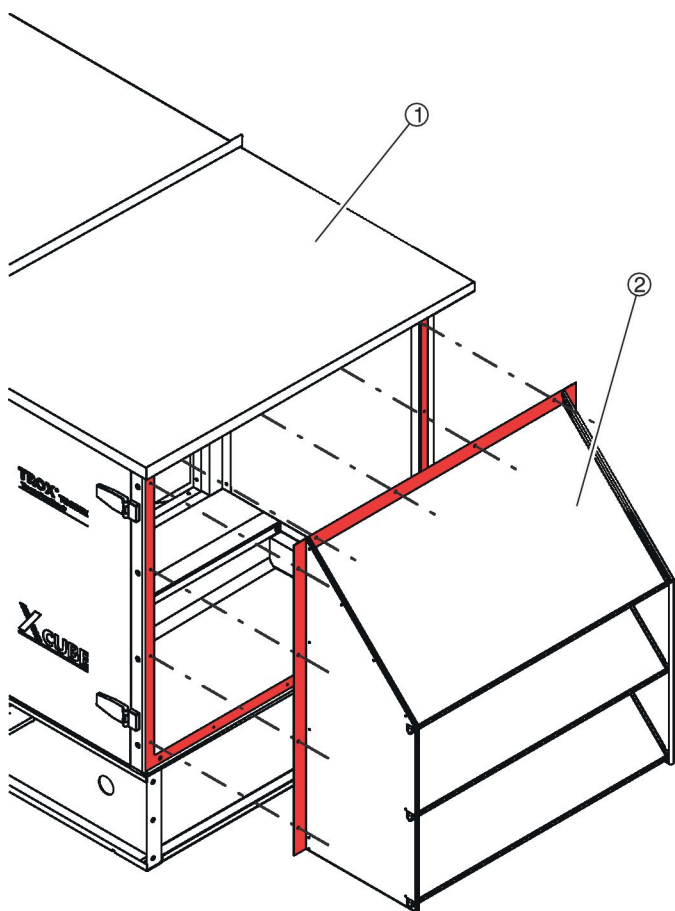

Fig. 19: Positioning the weather hood

4. ▶ Position the weather hood (Fig. 19 /2) precisely on the frame (Fig. 19 /1) so that the screw holes are in a line.

EX WARNING!

Risk of explosion!

The cover grille of the weather hood prevents foreign objects from being drawn into the unit. Using the weather hood without the cover grille may lead to an explosion.

Install the weather hood only with the cover grille attached.

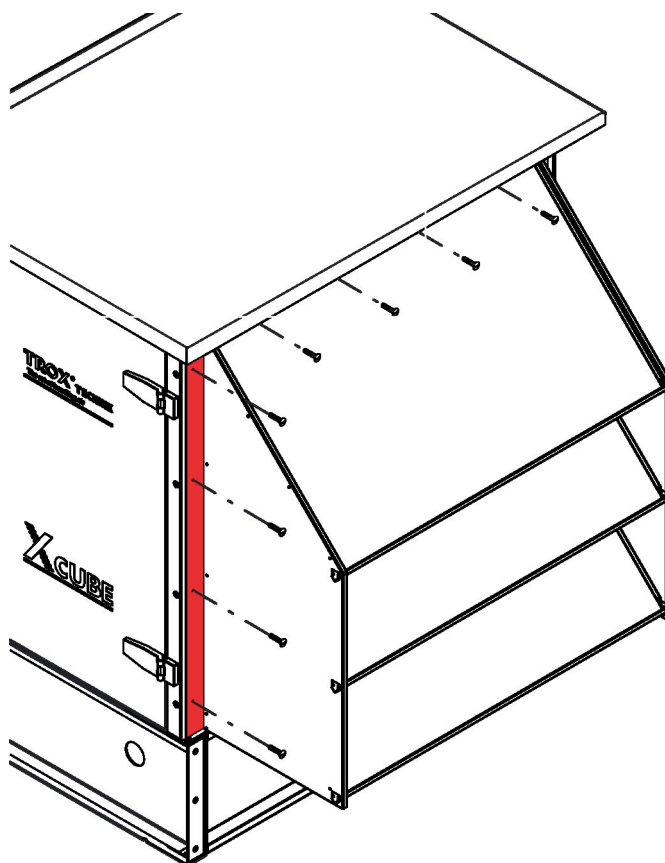

Fig. 20: Fixing the weather hood with screws

5. ▶ Screw the weather hood to the frame using M6x12 pan head screws.

Fitting base frame plugs

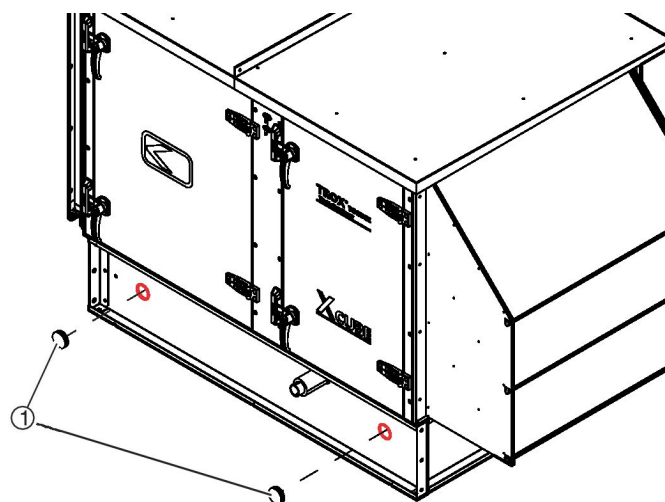

Fig. 21: Fitting plugs

6. ▶ Seal the transport openings in the base frame of the air handling unit with the plugs (Fig. 21 /1) provided.

Fixing cover strips to the intermediate frame

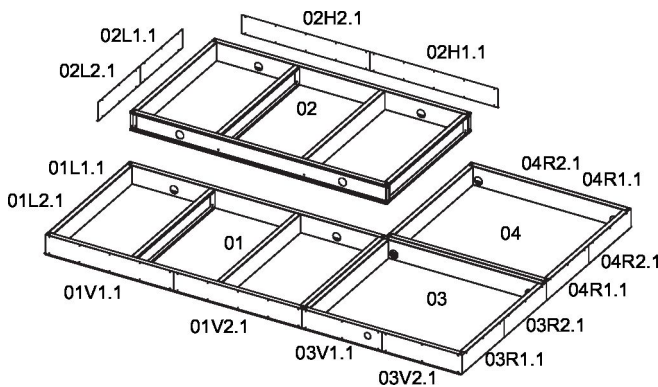

Fig. 22: Cover strip coding

7. ▶

! NOTICE!

Risk of water damage from incorrect assembly!

If units with an intermediate frame are installed outdoors, missing cover strips or incorrect assembly may lead to the ingress of water.

To prevent the ingress of water into the intermediate frame and hence into the unit, seal the intermediate frame with cover strips.

Fix the cover strips immediately after the assembly steps described above.

Each cover strip carries a code indicating its position (see table).

No. of the intermediate frame	Side code	Number (left → right)
01 ... 99	V	Front = operating side
	H	Rear
	L	Left
	R	Right

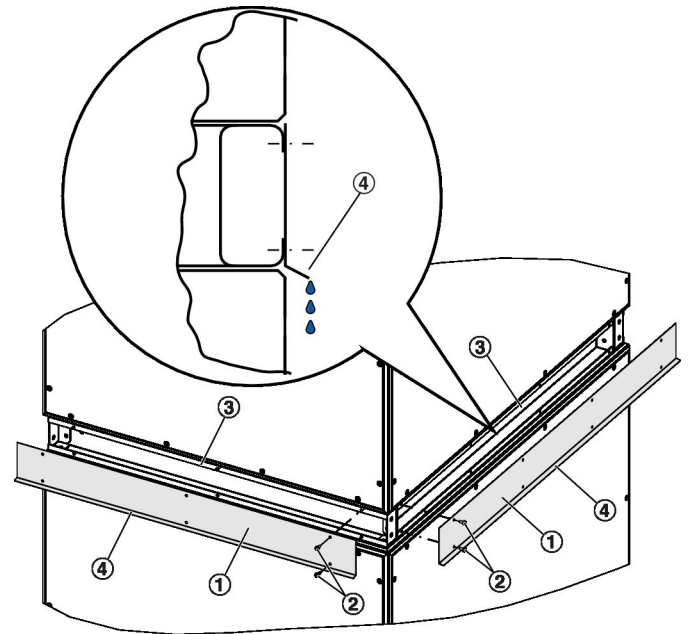

Fig. 23: Fixing cover strips

- 1 Cover strip for the intermediate frame
 - 2 Thread forming pan head screws M6 x 12 (M852AC6)
 - 3 Intermediate frame
8. ▶ Use pan head screws to attach the cover strips to the intermediate frame.
- ⇒ This will prevent water from getting into outdoor units with an intermediate frame.

4.4.4 Connecting the ductwork

EX WARNING!

Risk of explosion!

Due to normal leakage, an explosive atmosphere may escape from the inside of an AHU to the surrounding area (zonal dispersion). All of the following requirements have to be met to prevent an explosive atmosphere in the vicinity of the AHU:

- Leave a gap of at least 2 m between the outlet (exhaust air opening) and the intake (outdoor air opening). In addition, the openings should be facing a direction where they are not affected by wind or local emissions.
- Supply air ducts to rooms where there are potentially explosive atmospheres require shut-off dampers to EN 1775, class C 3, on the supply air and extract air openings. Ensure that the dampers close if the power fails (power off to close).

Failure to comply with these safety notes may lead to an explosion.

Installing ducts

Personnel:

- HVAC technician

Protective equipment:

- Industrial safety helmet
- Protective clothing
- Protective gloves
- Safety shoes

1. ▶ Connect the ductwork to the flexible connector of the air handling unit. Fix the ground cable between the duct and the air handling unit ↪ *'Fitting flexible connectors' on page 28*.
2. ▶ Insulate ducts (including flexible connectors and connecting frames).
3. ▶ For outdoor units: Protect ducts (including spigots and connecting frames) against the effects of weather.

4.4.5 Installing accessories

Install any supplied accessories (e.g. pressure transducers) and any accessories provided by others (e.g. actuators, frost sensors) according to the manufacturers' instructions.

5 Installation

5.1 Safety notes regarding installation

Explosion protection

 **WARNING!**

Risk of explosion!

Ignition sources, such as sparks, open flames or hot surfaces, can lead to explosions in an area with potentially explosive atmospheres.

- Only specially trained personnel must carry out work in an area with potentially explosive atmospheres.
- Get written permission before you start working in an area with potentially explosive atmospheres.
- If you have to carry out work, either ensure that there is no potentially explosive atmosphere, or at least avoid any source of ignition. If you have to work in a zone with potentially explosive atmospheres, use only equipment that has been approved for use in that particular zone.

Failure to comply with these safety notes may lead to an explosion.

Incorrect installation

 **WARNING!**

Risk to life from incorrect installation!

Incorrect installation can lead to potentially fatal situations and cause considerable damage to property.

- Only a skilled qualified electrician must connect the power supply.
- Any other installation job has to be carried out by an HVAC technician.

Hot surfaces

 **WARNING!**

Risk of injury from hot surfaces!

The surfaces of components can get very hot during operation. Skin contact with hot surfaces causes severe skin burns.

- Professionally insulate pipes that connect condensers or heating coils.

Interconnecting units and systems

 **WARNING!**

Risk of injury from interconnecting different units or systems!

Connecting an air handling unit to other units or systems (e.g. ductwork, pumps, refrigeration systems) can lead to dangerous situations and eventually cause serious or even fatal injuries.

- If you have to connect other units or systems to the air handling unit, connect them professionally.
- The system owner/HVAC contractor is responsible for the planning and installation of any additional safeguards.

Sharp edges, sharp corners and thin sheet metal parts

 **CAUTION!**

Danger of injury from sharp edges, sharp corners and thin sheet metal parts!

Sharp edges, sharp corners and thin sheet metal parts of the heat exchanger or of the cooling or heating coil may cause cuts or grazes.

- Be careful when working on these components.
- Wear protective gloves, safety shoes and a hard hat.

Inspection access doors slamming shut

 **WARNING!**

Risk of crushing from doors slamming shut

Inspection access doors may slam shut by the wind or if someone pushes them inadvertently, resulting in serious injury to the head and limbs.

- Secure each inspection access door with a hold open device.
- Secure inspection access doors without a hold open device against closing by suitable means.
- Do not reach between the door and door frame.
- Wear protective gloves and a hard hat when you open an inspection access door.

Crushing hazard.

 **WARNING!****Crushing hazard from movable parts!**

There is an increased risk of crushing on casing units, doors, panels and components of the device.

- Never reach between moving parts.
- Be careful when carrying out any work.
- Wear protective gloves, safety shoes and a hard hat.

5.2 Before installation

Before installation

- Have all the applicable documents at hand,
↳ *'Other applicable documentation'* on page 3
- Ensure that the installation requirements are met, see the order-specific data sheet for the air handling unit.
- Have all the required tools ready.

5.3 Sizing and connecting the condensate drain

Electric current

 **WARNING!****Danger of death due to electric current!**

If electrical components come into contact with water, e.g. from a leak, you could be seriously or even fatally injured. Water can also cause damage to the air handling unit.

- Lay drainage pipes in such a way that they cannot be accidentally damaged by mechanical impact or by heat.

Height of drain trap

! NOTICE!

Risk of leakages due to incorrect installation!

Do not connect the condensate drain to the sewerage system without a drain trap or with an unsuitable drain trap as this may result in air getting into the AHU.

- Use the AHU only with a suitable drain trap.
- Do not connect the drain trap to the drainage pipe; the water from the drain trap should flow to a gully.
- Use a different drain trap for each condensate drain. Do not connect condensate drains with each other.
- A distance from the floor must be maintained at the drain trap of the negative pressure side.

Calculate the height of a drain trap as shown below.

Symbol:

- P - Pressure inside the air handling unit [Pa]; be sure to use a positive value for calculations; take the final differential pressure (filter etc.) into consideration
- 1.5 - Safety factor to compensate for pressure fluctuations in the system such as those resulting from rapidly closing dampers (applies only to positive pressure)
- GR - Base frame height [mm]
- R - Distance R [mm]; minimum distance between condensate drain (centre line) and floor on the positive pressure side.
- X + 60 - Distance X + 60 [mm]; minimum distance between condensate drain (centre line) and floor on the negative pressure side
- H - Distance H [mm]; minimum distance between base frame lower edge and floor
- A - Distance A [mm]; distance between base frame lower edge and condensate drain (centre line); depends on the base frame height (GR) and unit width (B), see table
- B - Unit width (B)

Distance A

GR	Unit width	
	B ≤ 2448 [mm]	B > 2448 [mm]
	A	A
110	47	32
200	137	87
300	237	187

Negative pressure (extract air)

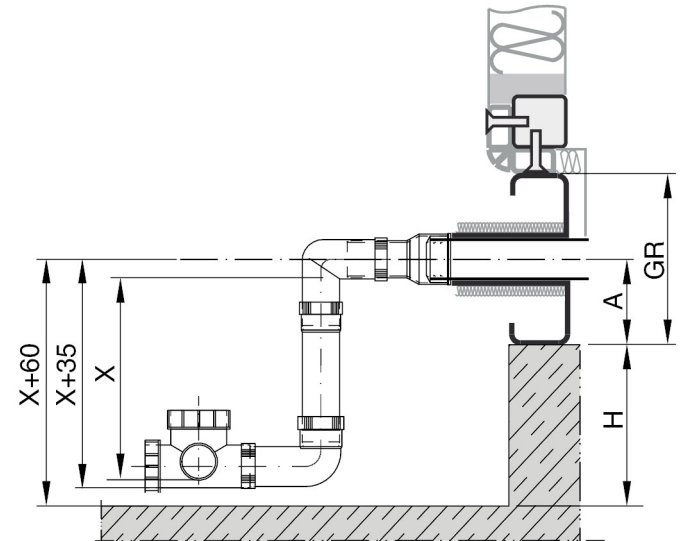

Fig. 24: Drain trap for negative pressure

Calculation to be used for negative pressure (2900 Pa max.):

- $X = P / 10$
X+35 has to be at least 140 mm
- $H = X + 60 - A$

Calculation example for X-CUBE:

Given data:

- P - 1800 Pa
- GR - 110 mm
- B - 1500 mm
- A - 47 mm, see table
- $X = 1800 \text{ Pa} / 10 = 180 \text{ mm}$
- $H = 180 + 60 - 47 = 193 \text{ mm}$

Sizing and connecting the condensate drain

Positive pressure (supply air)

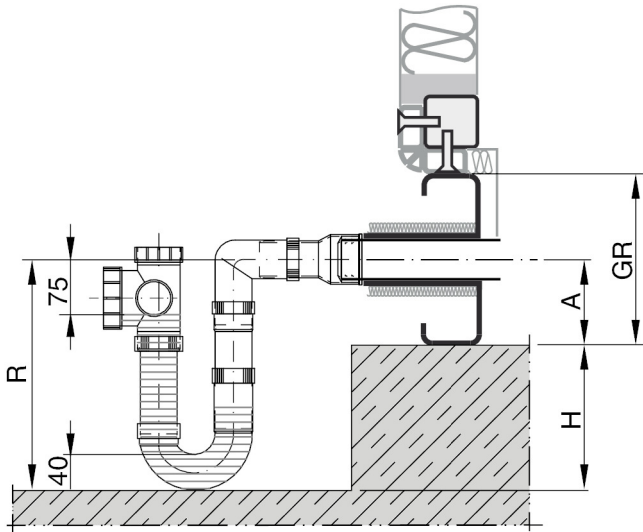

Fig. 25: Drain trap for positive pressure

Calculation to be used for positive pressure (1630 Pa max.):

- $R = P \times 1.5 / 10 + 115 (40 + 75)$
Always cut or extend pipes by the same length. Do not cut a pipe by more than 155 mm.; R has to be at least 215 mm.
- $H = R - A$

Calculation example for X-CUBE:

Given data:

- P - 1500 Pa
- GR - 200 mm
- B - 1500 mm
- A - 137 mm, see table

$$R = 1500 \text{ Pa} \times 1.5 / 10 + 115 \text{ mm} = \underline{340 \text{ mm}}$$

$$H = 340 - 137 = \underline{203 \text{ mm}}$$

Drain trap, connecting

Personnel:

- HVAC technician

Protective equipment:

- Industrial safety helmet
- Protective clothing
- Protective gloves
- Safety shoes

! NOTICE!

Risk of damage to property from incorrect pipe connections!

Take care to connect the pipes correctly as otherwise the pipes and the drain trap may be damaged beyond repair.

- Connect pipes in such a way that they are not affected by vibration and that no loads are imposed on them.
- If an AHU is installed outdoors, use suitable pipes and protect them from frost.

Drain trap connection dimensions (base frame)

- Outer diameter of drainage pipe - DN32
- 1 ¼"
- 42.3 mm

Drain trap connection dimensions (intermediate floor trough)

- Outer diameter of drainage pipe - DN20
- ¾"
- 26.9 mm

1. ▶ Calculate the height of the drain trap as shown above.

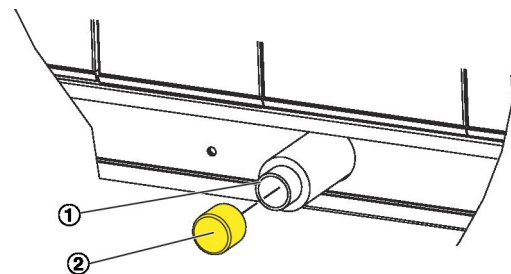

Fig. 26: Condensate drain

2. ▶ Remove the protective cap (Fig. 26 /2) from each drain (Fig. 26 /1) of the condensate drip tray.

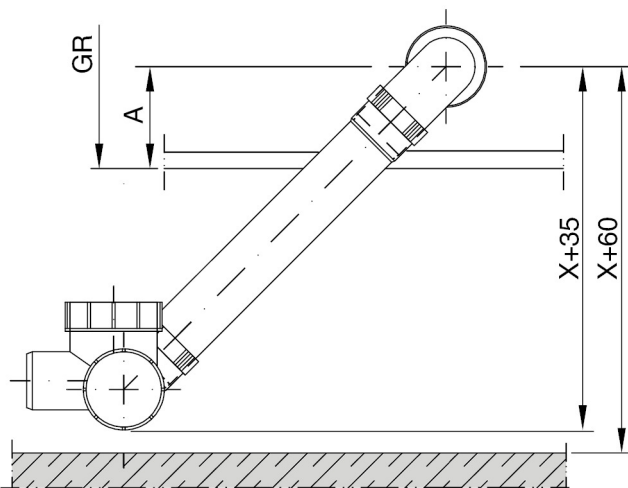

Fig. 27: Sloped pipe of a drain trap for negative pressure

3. ▶ Adjust the height of the drain tap based on the above calculation. Drain traps for negative pressure: Instead of shortening the pipe, you can install the drain trap so that it slopes.
4. ▶ Connect a drain trap to each condensate drain (Fig. 26 /1).

Do not connect the drain trap to the drainage pipe; the water from the drain trap should flow to a gully. For hygienic reasons, the floor clearance must be maintained for drain traps for negative pressure.

Air handling units to be installed outdoors or in areas at risk of frost require frost protection for the drain trap.

5.4 ☒ Connecting the heating coil/cooling coil

Electric current

⚠ WARNING!

Danger of death due to electric current!

If electrical components come into contact with water or a water glycol mixture, e.g. from a leak, you could be seriously or even fatally injured. Water can also cause damage to the air handling unit.

- Lay connecting cables in such a way that they cannot be accidentally damaged by mechanical impact or by heat.
- Do not lay connecting cables across electrical components or switch cabinets as people may become entangled in them.

Connect heat exchangers in a counter flow arrangement unless a parallel flow arrangement has been specified by the manufacturer. Only a counter flow arrangement ensures that the calculated capacity is achieved.



If you have to attach brackets or fasteners to the AHU panels or frame, use only those specially approved for your AHU as otherwise there is a risk of leakages.

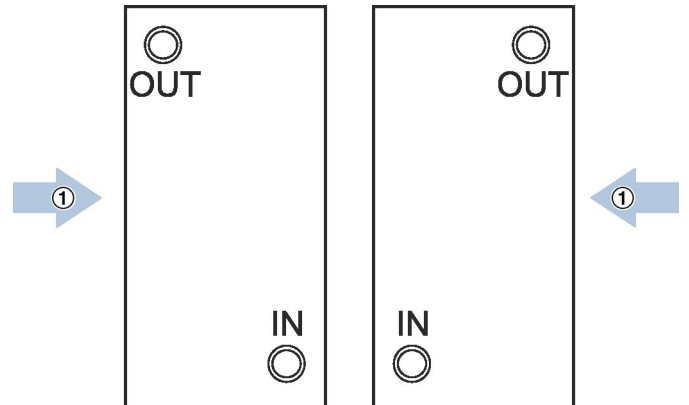

Fig. 28: Exemplary illustration of the heat exchanger connections in a counter flow arrangement

- 1 Airflow direction



Stickers on the connection side of the heat exchangers indicate the flow (Fig. 28 /IN) and return connections (Fig. 28 /OUT) for a counter flow arrangement.

In special constructions of the heat exchanger, these stickers may not show the correct type of connection. The heat exchangers must always be connected in a counter flow arrangement. For questions on the connections, please contact the unit manufacturer.

Connect slide-out heat exchangers and droplet eliminators with bends and detachable connections as otherwise you will not be able to withdraw them.

Personnel:

- HVAC technician

Protective equipment:

- Industrial safety helmet
- Hearing protection
- Protective clothing
- Protective gloves
- Safety shoes

! NOTICE!

Risk of damage to property from incorrect pipe connections!

Take care to connect the heat exchanger pipes correctly as otherwise the pipes may twist or become subject to adverse effects. This may eventually damage the heat exchanger beyond repair.

- Connect pipes in such a way that the heat exchanger is not affected by vibration and that no loads are imposed on it.
- If there is too much weight on a water pipe (by others), support the water pipe.
- Do not use the connection point of the heat exchanger as a fixing point for other parts.
- When you tighten thread connections, be sure to use a suitable tool (e.g. water pump pliers) to counter the tightening force as otherwise you may inadvertently damage the parts.
- If an AHU is installed outdoors, use suitable pipes and protect them from frost.
- Ensure that no air gets trapped in the pipes.

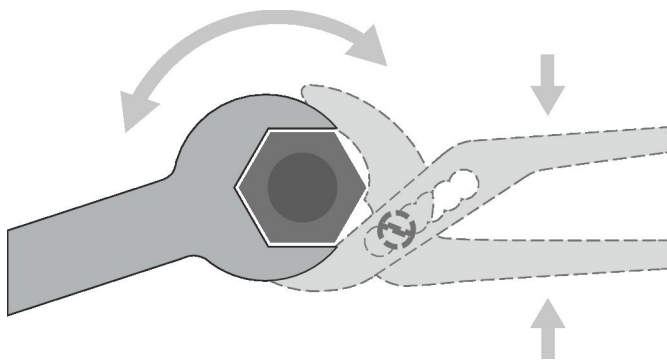

Fig. 29: Using water pump pliers to counter the tightening force

1. ▶ Hold the threaded pipe tail of the heat exchanger with water pump pliers (Fig. 29 /2).
2. ▶ Hold the threaded pipe tail with the pliers while you use a spanner (hexagonal profile, Fig. 29 /1) to connect the heat exchanger to the pipework (pipework by others).

Ventilation device

For optimum ventilation of the heat exchanger, we recommend that you install suitable air separators at the highest points of the system (e.g., above the air handling unit), which reduce the airflow velocity by increasing the cross section and can thus be ideally used for deaerating glycol systems.

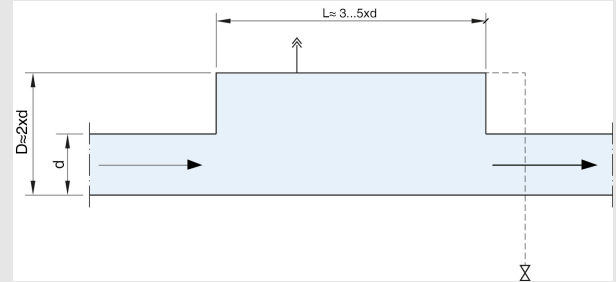

Fig. 30: Air separator with cross section enlargement

5.5 Connecting the run around coil system

The proper connection of the pipework between the heat exchangers of the AHU and the hydraulic unit is carried out by the customer.

Connect heat exchangers in a counter flow arrangement as only a counter flow arrangement ensures that the calculated capacity is achieved. Use only suitable parts and materials and use only the marked connection points to connect the hydraulic unit.



If you have to attach brackets or fasteners to the AHU panels or frame, use only those specially approved for your AHU as otherwise there is a risk of leakages.

Setting up and connecting the hydraulic unit**Personnel:**

- HVAC technician

Protective equipment:

- Industrial safety helmet
- Hearing protection
- Protective clothing
- Protective gloves
- Safety shoes
- Safety harness

2. ▶ Alignment of the hydraulic unit

- | | |
|---|---|
| using level-
ling feet
(optional) | - Adjust the feet of the hydraulic unit so that it is level (use a 19 mm wrench). |
| without feet | - Level out floor unevenness using materials provided by others, e.g. rubber or elastomer sheets. |

**WARNING!****Risk of explosion!**

The hydraulic unit is not explosion-proof; using it in areas with potentially explosive atmospheres may lead to an explosion.

Do not install the hydraulic unit in areas with potentially explosive atmospheres.

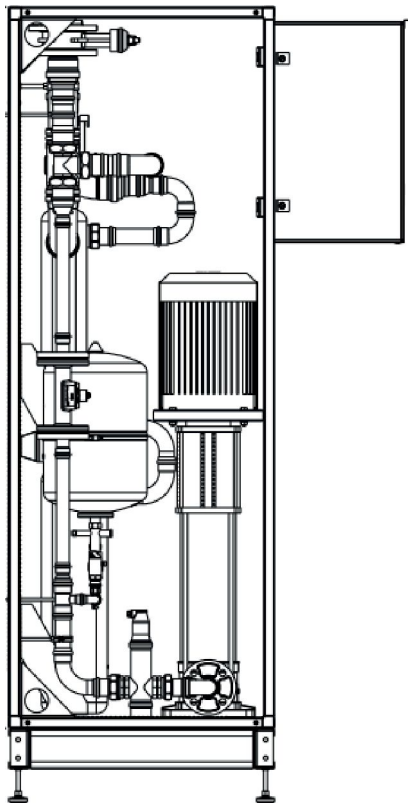

Fig. 31: Setting up the hydraulic unit

1. ▶ Install the hydraulic unit so that it is parallel to the wall and floor.

Connecting the air handling unit to the power su...

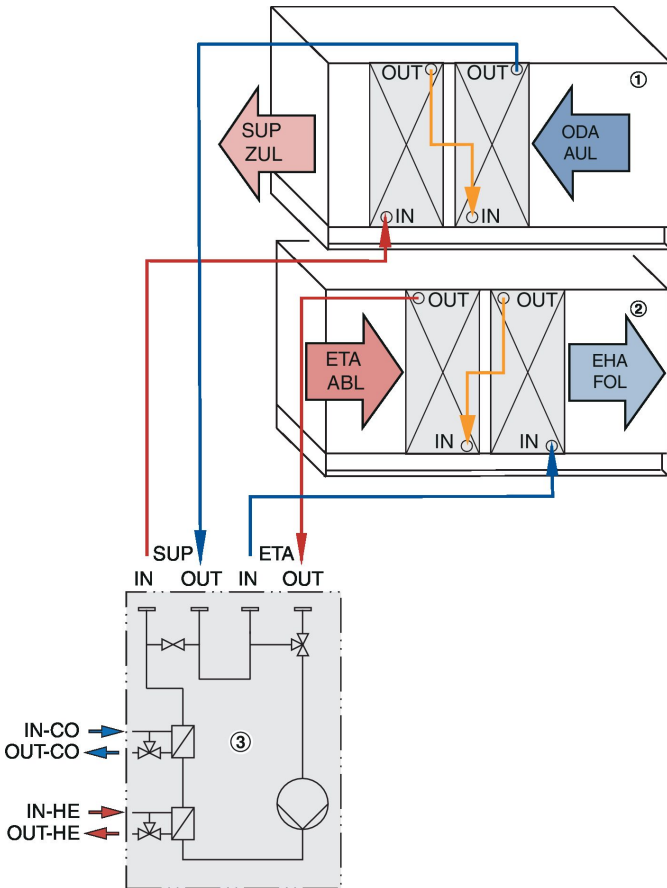

Fig. 32: Hydraulic system connection (example)

- ① Supply air unit
- ② Extract air unit
- ③ hydraulic unit
- IN Flow
- OUT Return

3. ▶ Connect the heat exchanger with the hydraulic unit (Fig. 32).

If there are several heat exchangers in airflow direction, connect the pipes in series.

The position of the connection points is given in the order-specific approval drawing.

If you are in doubt about the position of any pipes to be connected, please get in touch with our Technical Service.

Heat exchanger connection

Connection on hydraulic unit	Heat exchanger Air handling unit	Description
IN-ETA	IN	Flow – extract air
OUT-ETA	OUT	Return – extract air
IN-SUP	IN	Flow – supply air

Connection on hydraulic unit	Heat exchanger Air handling unit	Description
OUT-SUP	OUT	Return – supply air

4. ▶ Run-around coil systems with external feeding: Make the required connections (Fig. 32).

Connections for external feeding

Connection on hydraulic unit	External feeding
IN-CO	Water flow – cooling
OUT-CO	Return – cooling
IN-HE	Water flow – heating
OUT-HE	Return – heating

Ventilation device

For optimum ventilation of the heat exchanger, we recommend that you install suitable air separators at the highest points of the system (e.g., above the air handling unit), which reduce the airflow velocity by increasing the cross section and can thus be ideally used for deaerating glycol systems.

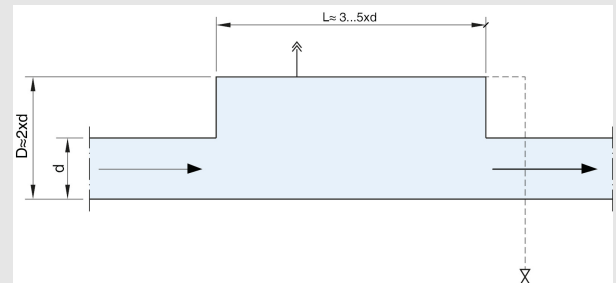

Fig. 33: Air separator with cross section enlargement

5.6 Connecting the air handling unit to the power supply

Installation according to ATEX

The installation of the electrical system has to follow the code of good practice based on the ATEX directive (e.g. IEC / EN 60079-14). The type of protection of the unit must not be compromised by the connection of other components, devices, pipes, cables etc. Irrespective of the type of protection, all cables to be used must have been tested and approved according to the code of good practice.



We recommend that you use screened cables for the signal lines. Have separate cables for supply voltage and signals, and separate grounds.

All cables must be fed into the casing through the provided cable glands. The connections are made in explosion-proof terminal boxes or connection boxes which have been approved for use in the respective zones with potentially explosive atmospheres. No loose terminals must be used in the terminal box or connection box. Once you have connected the cables, tighten the cable glands firmly in order to ensure IP protection (IP 66). In areas with potentially explosive atmospheres unused openings for cable penetration must be sealed with certified dummy plugs.

5.6.1 Electrical connection

Personnel:

- Skilled qualified electrician for Ex areas

Protective equipment:

- Industrial safety helmet
- Protective clothing
- Protective gloves
- Safety shoes



DANGER!

Danger of death due to electric current!

Danger of electric shock! Do not touch any live components!

- Only a skilled qualified electrician must connect the power supply.
- Lay connecting cables in such a way that they cannot be accidentally damaged by mechanical impact or by heat.
- Earth the air handling unit according to the state of the art.
- Secure all connections so that they cannot come loose.
- When you connect any electrical components, follow the manufacturers' specifications, the local regulations and codes of good practice (DIN/VDE), and the general recommendations for avoiding electromagnetic interference,
- If an AHU is installed outdoors, do not neglect the effects of weather on the unit (rain, snow, wind, sun etc.).



If you have to attach brackets or fasteners to the AHU panels or frame, use only those specially approved for your AHU as otherwise there is a risk of leakages. Avoid screw joints that pierce the outer shell of the unit; if you cannot avoid them, then at least seal them to prevent the ingress of water. The minimum protection level is IP 65.

1. ▶ Connect the electrical components, such as actuators.

There must be a mains isolator to de-energise the unit (all phases). There must be local isolators to de-energise (all phases) the fans. If mains isolator and local isolator are not part of the supply package, they have to be provided by others. Careful! Explosion hazard!

2. ▶ Include the air handling unit in the equipotential bonding arrangement,  on page 43.
3. ▶ Test protective conductors and insulation resistance to EN 60204 (VDE 0113). Take the appropriate safety precautions!

5.6.2 Connecting multileaf dampers

Personnel:

- Skilled qualified electrician for Ex areas

Use only cables that are designed for the supply voltage for which they will be used. The power rating is given on the actuator rating plate. The length and cross section as well as any contact resistance may increase voltage losses.

The cables to be used must comply with ATEX. The type of protection of the unit must not be compromised by the connection of pipes, cables etc. Irrespective of the type of protection, all cables to be used must have been tested and approved according to the code of good practice.

The connections are made in an explosion-proof terminal box that has been certified for the relevant zones.

No loose terminals must be used in the terminal box. Once you have connected the cables, tighten the cable glands firmly in order to ensure IP protection (IP 66).

In areas with potentially explosive atmospheres unused openings for cable penetration must be sealed with certified dummy plugs.

A skilled qualified electrician has to select the correct cable types and sizes.

DANGER!

Danger of electric shock! Do not touch any live components! Electrical equipment carries a dangerous electrical voltage.

- Only skilled qualified electricians are allowed to work on the electrical system.
- Switch off the power supply before working on any electrical equipment.

- ▶ Connect the actuator to the explosion-proof terminal box as indicated on the actuator or in the manufacturer's product documentation.

Explosion-proof electric actuators

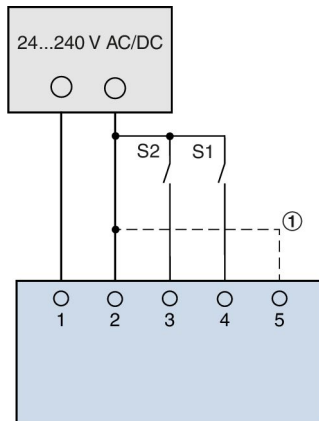

Fig. 34: 2-wire control

- ① Wire link between terminals 2 and 5: Spring return ~3s (only ExMax15-SF)
- S1 open and S2 open: Actuator has stopped (any position)
- S1 closed: Direction of rotation 1
- S1 open, S2 closed: Direction of rotation 2

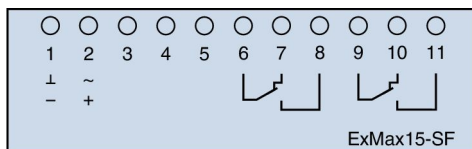

Fig. 35: Terminal connections in terminal box Ex-Max15-SF

- 1 ⊥, -
- 2 ~, +
- 3 Control voltage for direction of rotation 1
- 4 Control voltage for direction of rotation 2
- 5 Input for 2–5 wire link, spring return ~3s
- 6 Common contact
- 7 Mechanical stop 1 < 5°
- 8 Mechanical stop 1 > 5°
- 9 Common contact
- 10 Mechanical stop 2 < 85°
- 11 Mechanical stop 2 > 85°

If both auxiliary switches are used, then the switching voltages must be the same.

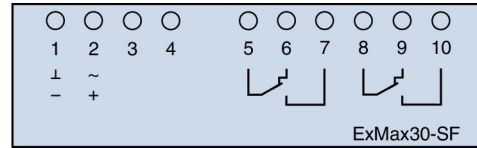

Fig. 36: Terminal connections in terminal box Ex-Max30-SF

- 1 ⊥, -
- 2 ~, +
- 3 Control voltage for direction of rotation 1
- 4 Control voltage for direction of rotation 2
- 5 Common contact
- 6 Mechanical stop 1 < 5°
- 7 Mechanical stop 1 > 5°
- 8 Common contact
- 9 Mechanical stop 2 < 85°
- 10 Mechanical stop 2 > 85°

If both auxiliary switches are used, then the switching voltages must be the same.

Limit switch

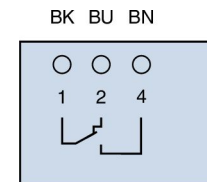

Fig. 37: Connecting cable core identification for limit switch

- 1 Common contact
- 2 NC contact
- 4 NO contact

5.6.3 Fans used with a frequency inverter

Installation:

- Make sure that the fan motor allows for connection to a frequency inverter.
- Install the frequency inverter outside the Ex zone.
- Use shielded cables to connect the fan motor to the frequency inverter.
- Use one of the following protection systems for the fan (careful - explosion hazard!):
 - PTC thermistor
 - Temperature sensor
 - Overcurrent protection device

These systems are the only way to ensure that the motor is immediately switched off in case of a fault (e.g. from a bearing, winding).

EX WARNING!**Explosion hazard due to incorrect installation!**

Fuses and circuit breakers are no adequate motor protection. Inadequate motor protection can lead to an explosion.

More on fans:

↪ *Appendix A.1 'Ziehl-Abegg RH..C / ER..C fan' on page 61*

↪ *Appendix A.2 'Nicotra Gebhardt RLM... fan' on page 74*

5.6.4 Equipotential bonding**Personnel:**

- Skilled qualified electrician for Ex areas

Equipotential bonding prevents electrostatic ignition hazards.

Connect wires and cables safely and permanently and so that they cannot come loose.

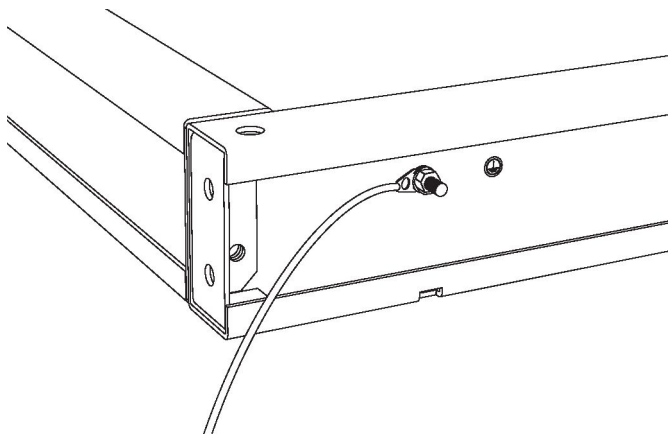

Fig. 38: Terminal point for equipotential bonding on the AHU base frame

Connect the following components to the equipotential bond (by others):

- Air handling unit, Fig. 38
- Ducts and flexible connectors
- Duct insulation
- Components and devices by others
- Conductive components such as metal cable ducts

Bypass all non-conductive components (e.g. flexible connectors, anti vibration elements) with an equipotential bonding cable.

5.6.5 Lightning protection for outdoor units

Explosion-proof air handling units for outdoor installation need to be fitted with an adequate lightning protection system (by others). Connect all metal parts of the supporting construction (ladders, platforms etc.) with earth conductors. Air handling units themselves are like a metal enclosure and are hence protected against lightning anyway.

Metal constructions with internal components (ducts, pipes etc.) must not be used for the dissipation of lightning energy. To avoid direct lightning strikes, such constructions have to be installed such that they are protected by existing arrest equipment (lightning rods etc.). To prevent flash overs between the metal constructions and the arrest equipment of the lightning protection system, the metal constructions have to be included in the lightning equipotential bonding arrangement to IEC/EN 62305-1 (VDE 0185-305-1).

5.7 Integrating the air handling unit with the central BMS

It is the duty of the system owner/HVAC contractor to integrate the air handling unit with the building services and to ensure conformity, ↪ *'System owner's obligations' on page 7* and ↪ *'Conformity assessment' on page 22*.

6 Initial commissioning

6.1 Safety notes regarding initial commissioning

Explosion protection

 **WARNING!**

Risk of explosion!

When you have to perform initial commissioning of an explosion-proof air handling unit:

- Get written permission before you start working in an area with potentially explosive atmospheres.
- Carry out commissioning and any test run only after you have ensured that there is no potentially explosive atmosphere.

Failure to comply with these safety notes may lead to an explosion.

Incorrect initial commissioning

 **WARNING!**

Risk to life from incorrect initial commissioning!

Incorrect initial commissioning can lead to potentially fatal situations and cause considerable damage to property.

- Only skilled qualified electricians must work on the electrical system and on motors.
- All other initial commissioning steps must be carried out by an HVAC technician.

Inspection access doors on the discharge side

 **CAUTION!**

Risk of injury from a strong airflow on the discharge side of fans!

When you open an inspection access door on the discharge side of the fan, the velocity and pressure of the airflow may cause the door to suddenly swing open until it is caught by the safety catch. You could be injured.

- Be careful when you open inspection access doors on the discharge side.

Sharp edges, sharp corners and thin sheet metal parts

 **CAUTION!**

Danger of injury from sharp edges, sharp corners and thin sheet metal parts!

Sharp edges, sharp corners and thin sheet metal parts of the heat exchanger or of the cooling or heating coil may cause cuts or grazes.

- Be careful when working on these components.
- Wear protective gloves, safety shoes and a hard hat.

Crushing hazard.

 **WARNING!**

Crushing hazard from movable parts!

There is an increased risk of crushing on casing units, doors, panels and components of the device.

- Never reach between moving parts.
- Be careful when carrying out any work.
- Wear protective gloves, safety shoes and a hard hat.

Inspection access doors slamming shut

 **WARNING!**

Risk of crushing from doors slamming shut

Inspection access doors may slam shut by the wind or if someone pushes them inadvertently, resulting in serious injury to the head and limbs.

- Secure each inspection access door with a hold open device.
- Secure inspection access doors without a hold open device against closing by suitable means.
- Do not reach between the door and door frame.
- Wear protective gloves and a hard hat when you open an inspection access door.

6.2 Before initial commissioning

The air handling unit has been erected, assembled, and installed according to this manual.

Before initial commissioning, check the casing and the following parts for damage and correct position:

- Inspection access doors and openings
- Seals
- Handles and levers
- Connections

- Inspection window
- Panels

Before initial commissioning:

- Remove protective film, if any
- Check the unit for leakages
- Check inspection access doors and openings for function and tolerance
- Adjust the door closure, ↪ *on page 45*
- Adjust inspection access doors, ↪ *on page 45*
- Set up the centrifugal fan, ↪ *'Set up the centrifugal fan' on page 47*
- Insert the filters, ↪ *'Filters, inserting' on page 48*
- Set up the heating coil/cooling coil, ↪ *'Commissioning the heating coil/cooling coil' on page 49*
- Set up the multileaf dampers, ↪ *'Setting up multileaf dampers' on page 51*
- Set up the sound attenuator, ↪ *'Setting up sound attenuators' on page 52*
- Set up the run around coil system, ↪ *'Commissioning the run around coil system' on page 51*
- Set up the plate heat exchanger, ↪ *'Setting up the plate heat exchanger' on page 52*
- Remove the protective caps from the condensate drains and connect the drain trap, ↪ *Chapter 5.3 'Sizing and connecting the condensate drain' on page 34*
- Clean the air handling unit, ↪ *Operating manual, Maintenance.*

6.3 Setting up and adjusting AHU casing units

6.3.1 Inspection access doors

The door leaf can be adjusted vertically with the slotted holes in the hinge block, and horizontally with the slotted holes in the hinge bracket.



The two-part hinge bracket simplifies mounting and removing inspection access doors. To remove an inspection access door, remove the hinge bracket screws.

Adjusting inspection access doors

Personnel:

- HVAC technician

Protective equipment:

- Industrial safety helmet
- Protective clothing
- Protective gloves
- Safety shoes

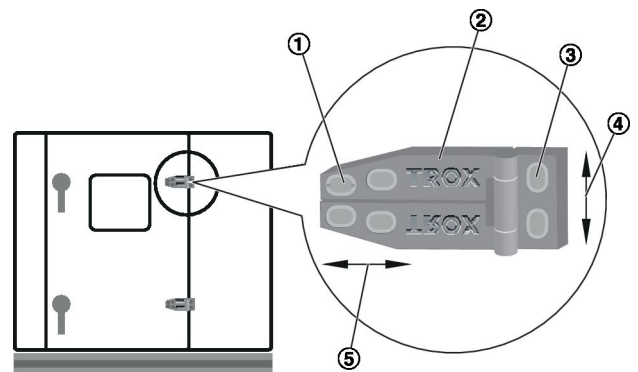

Fig. 39: Adjusting the door

1. ▶ Remove the hinge covers (Fig. 39 /1).

Adjusting the door horizontally

2. ▶ Loosen the screws of all hinge brackets (Fig. 39 /2) of a door.
3. ▶ Adjust the door horizontally (Fig. 39 /5).
4. ▶ Tighten the screws of the hinge brackets (Fig. 39 /2).

Adjusting the door vertically

5. ▶ Loosen the screws of all hinge blocks (Fig. 39 /3) on a door.
6. ▶ Adjust the door vertically (Fig. 39 /4).
7. ▶ Tighten the screws of the hinge blocks (Fig. 39 /3).

Adjusting the staple

Leaking inspection access doors

The contact pressure of the locking mechanism of the inspection access doors can be increased in the event of leaks using a compensating plate.

The compensating plate for this can be ordered from the Technical Service: article no.: A00000077107

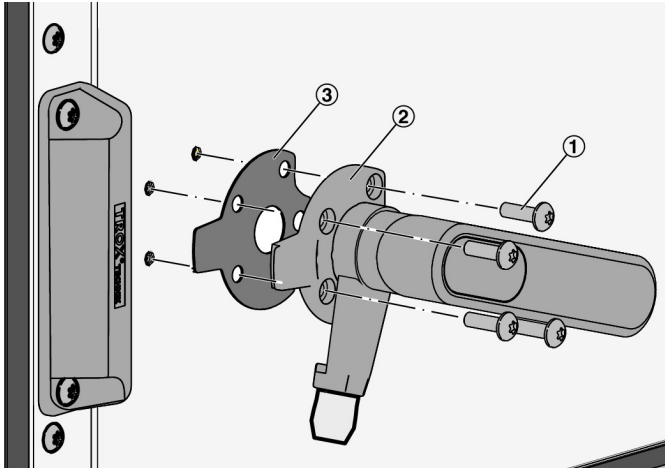

Fig. 40: Adjusting contact pressure of the inspection access door

8. ▶ Loosen screws (Fig. 40 /1) of the locking mechanism (Fig. 40 /2) and insert the compensating plate (Fig. 40 /3). Install by following these steps in reverse order and tighten the screws.

⇒ The inspection access doors have been adjusted.

6.3.2 Centrifugal fan

Operating point

The control system calculates the operating point and sets the default setpoint value for the fan.

During commissioning ensure that the following values are not exceeded:

- Maximum fan speed
- Minimum fan speed
- Motor rating

Do not change the clearance between the rotor and the bellmouth inlet.

Pressure measuring devices

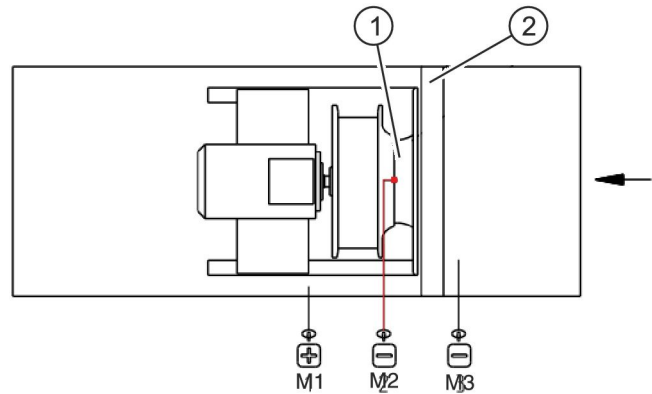

Fig. 41: Pressure measurement point

- 1 Bellmouth inlet
- 2 Partitioning panel
- M1 Pressure measurement point in the fan chamber
- M2 Pressure measurement point on the bellmouth inlet
- M3 Pressure measurement point in front of the partitioning panel

The fans may be factory fitted with pressure measuring devices (optional). The following pressure values are measured at the pressure measurement point (Fig. 41 /M2) in the bellmouth inlet (Fig. 41 /1), the pressure measurement point (Fig. 41 /M1) in the fan chamber, and the pressure measurement point (Fig. 41 /M3) in front of the partitioning panel.

Pressure	Determined from
Static fan pressure increase	Differential pressure between M1 and M3
Effective pressure (Δp_w) of the fan	The differential pressure between M2 and M3 is used to calculate the volume flow rate.

Calculation of the volume flow rate

$$\dot{V} = k \times \sqrt{\Delta p_w}$$

The K value is given on the TROX fan rating plate on the air handling unit.

This value may be different from the K value on the rating plate from the fan manufacturer (which should not be used for the calculation).

Set up the centrifugal fan

WARNING!

Risk of injury from the incorrect handling and operation of fans!

Incorrect handling, e.g. reaching into rotating parts, can lead to serious injuries.

- Do not reach into the moving fan or tamper with it.
- The fan does not stop immediately! Check that no parts are moving before you open an inspection access door.
- Do not put a damaged or defective fan into operation.
- Do not exceed a fan's maximum capacity, e.g. when there are strong vibrations or against a closed multileaf damper.
- Switch off the system before you start working on movable fan parts and secure it against accidentally being switched on again. Wait until all parts have come to a standstill.

Switch off the system before you start working on movable fan parts and secure it against accidentally being switched on again. Wait until all parts have come to a standstill.

Switch off the AHU before you start working on movable fan parts and secure it against accidentally being switched on again. Wait until all parts have come to a standstill.

Switch off the system before you start working on movable fan parts and secure it against accidentally being switched on again. Wait until all parts have come to a standstill.

WARNING!

Risk of explosion from damaged fan parts!

- Do not use a damaged fan or a fan that makes a grinding noise.
- The power consumption must not exceed the specified nominal current.
- Make sure that the maximum motor speed is not exceeded.

Personnel:

- Skilled qualified electrician

Protective equipment:

- Protective clothing
- Hearing protection
- Industrial safety helmet
- Protective gloves
- Safety shoes

1. ▶ Remove the red transport protection devices from the fan.

2. ▶ Check the fan for shipping damage, imbalance, corrosion and contamination.
3. ▶ Check whether the fan has a cover grille and whether the grille is intact.



Fans for use in areas with potentially explosive atmospheres are fitted with a cover grille that prevents foreign objects from being drawn into the fan. The fan must not be used without a cover grille.

4. ▶ Check ducts and fan for foreign matter.
5. ▶ Turn the rotor manually to check that it moves freely.



The clearance between the rotor and the bellmouth inlet may have changed due to vibrations during transport. Check before commissioning that the distance between the inner edge of the rotor and the outer surface of the bellmouth inlet is the same everywhere.

6. ▶ Tighten all fixing screws.
7. ▶ Check the bearings and relubricate them if necessary.
8. ▶ Make sure that the multileaf dampers are open, ↪ *'Setting up multileaf dampers' on page 51*.
9. ▶ Check the direction of rotation of the fan by switching on the motor for a moment.



Nominal motor power of 3 kW and higher: star delta start.



In units with a fan with asynchronous motor, the arrow indicating the direction of rotation can be found on the fan casing.

In units with an EC fan, the fan will automatically start in the correct direction of rotation.

10. ▶ You can change the direction of rotation by swapping the terminal connections.
11. ▶ Ensure that the unit has been correctly earthed.
12. ▶ Close all inspection access doors on the air handling unit ↪ *Operating manual*.

13. ▶ Measure the power consumption with the inspection access doors closed and compare it with the nominal current.



If the power consumption exceeds the value given on the motor rating plate, switch off the fan immediately.

14. ▶ Check the function of the anti-vibration elements.
15. ▶ Moving towards the operating point, check whether the fan is running smoothly and with minimal vibration only.



If you can see or hear the fan vibrating, switch off the air handling unit, ☞ Contacting the TROX Technical Service .

16. ▶ Carry out a vibration test according to the fan manufacturer's instructions:
☞ Appendix A.1 'Ziehl-Abegg RH..C / ER..C fan' on page 61
☞ Appendix A.2 'Nicotra Gebhardt RLM... fan' on page 74



The fan must be permanently monitored for vibration. We recommend using an explosion-proof vibration monitoring system.

17. ▶ Measure the volume flow rate.
⇒ The centrifugal fan has been set up.

6.3.3 Filter

Filters, inserting

Personnel:

- HVAC technician

Protective equipment:

- Industrial safety helmet
- Protective clothing
- Protective gloves
- Safety shoes



WARNING!

Risk of explosion from unsuitable filters!

For explosion-proof air handling units please note:

- Use only filters suitable for use in areas with potentially explosive atmospheres.
- No electrostatic charge must build up on filters; surface resistance <math><10^9</math> ohms.
- Ensure that the filter frame is made of a conductive material and that it is connected to the equipotential bonding.



- *Filters may become contaminated due to construction work in the building which is why we recommend that you replace all filters after the construction phase and initial commissioning.*
- *Do not operate the air handling unit without a filter.*
- *One spare filter element should always be available so that the air handling unit does not have to be switched off. Store filters in a dry place, free from dust, so that they will not be contaminated or damaged. Do not use filters beyond the use before date. Original TROX filters carry a sticker on the frame with both the use before date and information on how to order replacements.*



Follow the filter manufacturer's instructions for installation and commissioning of a filter.

☞ Appendix A.5 'EMW compact filter' on page 129

☞ Appendix A.4 'GEA pocket filter' on page 126

1. ▶ Ensure that the filters are intact.



Defective filters may become torn while in use and will then no longer be effective.

2. ▶ Remove any dust from all parts that are in upstream direction before the filter.



Clean the air handling unit and ventilation ducts before you install any filter of class F9 or higher.

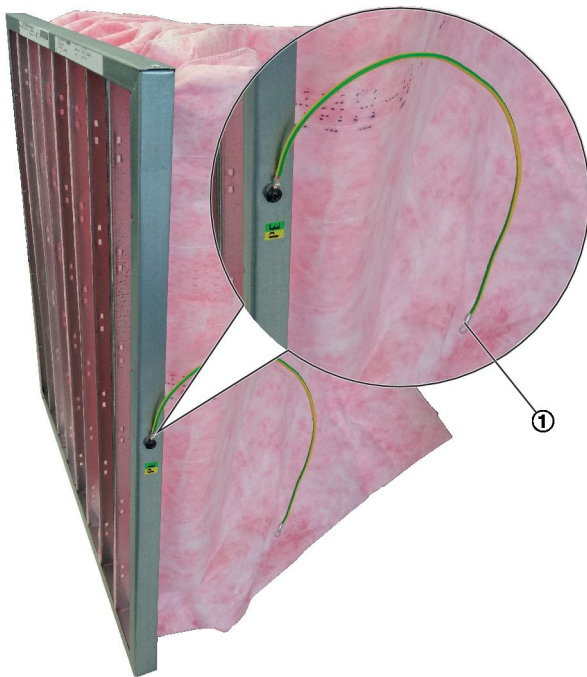

Fig. 42: Connecting the filter ground cable

3. ▶ Fit filters into the installation subframe and fix them with the clamping elements. Make sure that they are tightly seated.

EX WARNING!

Risk of explosion from incorrect filter installation!

When you assemble the filter pockets, connect the eye (Fig. 42 /1) of the ground cable to the earth bar so that a conducting connection is established; secure the cable against coming loose.

⇒ The filter has been set up.

6.3.4 ☒ Heating coil/cooling coil

Heat transfer fluids with glycol

! WARNING!

Health risk from heat transfer fluids that contain glycol!

The heat transfer fluids in the heating coil, cooling coil and run around coil system contain glycol, which can damage your health if it comes into contact with your skin, if you swallow it or if you inhale the vapour or mist.

- Avoid contact with heat transfer fluids that contain glycol.
- Work must only be carried out by skilled qualified refrigeration technicians, HVAC technicians or the ☒ *TROX Technical Service* .
- Do not eat, drink or smoke while handling heat transfer fluids that contain glycol.
- Wash your hands when you interrupt or finish your work.
- If you have come into contact with a heat transfer fluid that contains glycol, follow the first aid instructions given on the safety data sheet for the heat transfer fluid.
- When you have to handle a heat transfer fluid that contains glycol, wear the personal protective equipment specified in the safety data sheet for the heat transfer fluid.

Commissioning the heating coil/cooling coil

Personnel:

- HVAC technician

Protective equipment:

- Industrial safety helmet
- Protective clothing
- Protective gloves
- Safety shoes



Ensure that the maximum pressure values given in the technical data are not exceeded.

Use appropriate measures to protect the water system from frost. Frost protection can be achieved with a water glycol mixture or with a special anti-frost thermostat.

Optimum ventilation

For the best possible ventilation, we recommend installing on-site ventilation equipment at the highest point of the system; see  on page 37.

1. ▶ Ensure that the flow and return connections are correct.
2. ▶ Check that fittings are correctly installed.
3. ▶ Flush the system to remove any contamination.
4. ▶ Open vents (unless automatic vents have been installed).



Evaporators: As soon as you open the heat exchanger connection, the contained nitrogen shield gas content should escape with a hissing sound. The absence of this sound indicates a leak which has to be fixed before commissioning.

5. ▶



For glycol water mixtures we recommend ready-to-use formulations. See the order-specific air handling unit data sheet from TROX for the mixing ratio.

The correct mixing ratio is important:

- Too much glycol will impair performance
- Too little glycol may lead to frost damage

.

Only use one of the following glycols for the air handling unit:

- Propylene glycol
- Ethylene glycol

Slowly pour the heat transfer fluid into the heat exchanger at the lowest point in the system. As you fill the system, check that all external and internal screw joints and connections are tight.

6. ▶ Vent the heating coil/cooling by opening the upper spigot and the bleed screw.



If the air heater is not properly vented, air bubbles may form and impair the performance.

7. ▶ Close any vents.
8. ▶ Clean the condensate drip tray and drain.
9. ▶ Set up the droplet eliminator.
10. ▶ Fill the drain trap with water.

NOTICE!

Risk of damage to property!

- When you tighten thread connections, be sure to use a suitable tool (e.g. water pump pliers) to counter the tightening force as otherwise you may inadvertently damage the parts.

11. ▶ Check the flange screw joints and tighten them if necessary.

⇒ The heating coil/cooling coil has been set up.

6.3.5 **Run around coil system**

The run around coil system must only be put into operation after the entire system has been professionally connected and checked (both hydraulic and electrical systems). These checks have to be recorded, and the results have to be available at the time of commissioning.

Heat transfer fluids with glycol



WARNING!

Health risk from heat transfer fluids that contain glycol!

The heat transfer fluids in the heating coil, cooling coil and run around coil system contain glycol, which can damage your health if it comes into contact with your skin, if you swallow it or if you inhale the vapour or mist.

- Avoid contact with heat transfer fluids that contain glycol.
- Work must only be carried out by skilled qualified refrigeration technicians, HVAC technicians or the  TROX Technical Service .
- Do not eat, drink or smoke while handling heat transfer fluids that contain glycol.
- Wash your hands when you interrupt or finish your work.
- If you have come into contact with a heat transfer fluid that contains glycol, follow the first aid instructions given on the safety data sheet for the heat transfer fluid.
- When you have to handle a heat transfer fluid that contains glycol, wear the personal protective equipment specified in the safety data sheet for the heat transfer fluid.

Commissioning the run around coil system

Personnel:

- HVAC technician

Protective equipment:

- Industrial safety helmet
- Protective clothing
- Protective gloves
- Safety shoes



Ensure that the maximum pressure values given in the technical data are not exceeded.

Use appropriate measures to protect the water system from frost. Frost protection can be achieved with a water glycol mixture or with a special anti-frost thermostat.



Optimum ventilation

For the best possible ventilation, we recommend the installation of ventilation equipment by others at the highest point of the system, see ↗ 'Setting up and connecting the hydraulic unit' on page 39.

1. ▶ Ensure that the flow and return connections are correct.
2. ▶ Check that fittings are correctly installed.
3. ▶ Flush the system to remove any contamination.
4. ▶ Check the run around coil system for leaks.
5. ▶ Open vents (unless automatic vents are installed).
6. ▶



For glycol water mixtures we recommend ready-to-use formulations. See the order-specific air handling unit data sheet from TROX for the mixing ratio.

The correct mixing ratio is important:

- Too much glycol will impair performance
- Too little glycol may lead to frost damage

Only use one of the following glycols for the air handling unit:

- Propylene glycol
- Ethylene glycol

Slowly pour the heat transfer fluid into the heat exchanger at the lowest point in the system. As you fill the system, check that all external and internal screw joints and connections are tight.

7. ▶ Vent the heating coil/cooling by opening the upper spigot and the bleed screw.



If the air heater is not properly vented, air bubbles may form and impair the performance.

8. ▶ Close any vents.
9. ▶ Clean the condensate drip tray and drain.
10. ▶ Set up the droplet eliminator.
11. ▶ Fill the drain trap with water.

! NOTICE!

Risk of damage to property!

- When you tighten thread connections, be sure to use a suitable tool (e.g. water pump pliers) to counter the tightening force as otherwise you may inadvertently damage the parts.

12. ▶ Check the flange screw joints and tighten them if necessary.

⇒ The run around coil system has been set up.

6.3.6 Multileaf dampers

Movable parts of multileaf dampers



WARNING!

Crushing hazard from movable parts!

Closing multileaf dampers may crush your hands and arms.

- Do not reach between the damper blades.
- Prevent access to crush points: Either install dampers on ducts or use fixed guards.
- Before you open an inspection access door, switch off the air handling unit and secure it against being switched on accidentally.

Setting up multileaf dampers

Set the AHU control system in such a way that the fan does not operate against a closed damper.

TROX does not accept liability for damages resulting from incorrect operation. To prevent damage due to pressure surges from fire dampers, pressure relief dampers should be installed.



TROX cannot guarantee leak-free dampers if the actuators are provided and installed by others.

Powered dampers

Personnel:

- HVAC technician

Protective equipment:

- Industrial safety helmet
- Protective clothing
- Protective gloves
- Safety shoes

- ▶ Adjust the linkage in such a way that the angle of rotation is 90° and the dampers close completely.

⇒ Powered multileaf dampers have been set up.

Coupled dampers (for plate heat exchanger)

Personnel:

- HVAC technician

Protective equipment:

- Industrial safety helmet
- Protective clothing
- Protective gloves
- Safety shoes

- ▶ Check that the friction locking of the linkage is correct.
- ▶ Check the direction of rotation direction and ensure that the blades fully open and close.
- ▶ Check that all screw joints and connections are tight.

⇒ The coupled multileaf dampers have been set up.

6.3.7 Sound attenuator

Setting up sound attenuators

The splitter filling is made of non-combustible absorption material to DIN 4102.

Personnel:

- HVAC technician

Protective equipment:

- Industrial safety helmet
- Protective clothing
- Protective gloves
- Safety shoes

- ▶ Check splitters for damage and contamination.
- ▶ Check sound attenuator splitters (offset resonating panels, perforated plates, splitters) for consistent equipotential bonding.

WARNING!

Risk of explosion from inadequate equipotential bonding!

If equipotential bonding is inadequate or non-existent, internal circuits may create a spark or enough heat to become a source of ignition (e.g. electrostatic discharge).

⇒ The sound attenuator has been set up.

6.3.8 Plate heat exchanger

Setting up the plate heat exchanger

Personnel:

- HVAC technician

Protective equipment:

- Industrial safety helmet
- Protective clothing
- Protective gloves
- Safety shoes

NOTICE!

Risk of damage to property from extreme pressure drop!

An extreme pressure drop between the supply air and extract air flows can damage the heat exchanger.

- Ensure that the maximum differential pressure (approx. 1000 Pa, depending on unit design) is not exceeded.
- Check differential pressure on pressure monitors according to the specified intervals.

- ▶ Check and, if necessary, clean the plate heat exchanger to remove foreign matter and contamination.

⇒ The plate heat exchanger has been set up.

6.3.9 Electrical system

Personnel:

- Skilled qualified electrician for Ex areas
- HVAC technician

Protective equipment:

- Industrial safety helmet
- Protective clothing
- Protective gloves
- Safety shoes

Before commissioning, the electrical system has to be tested according to IEC 60364-6 (VDE 0100-600). As part of this test, all contacts have to be checked for correct seating. This applies in particular to motor terminal blocks, fuses, local isolators and equipotential bonding.

- Has the sound attenuator been set up?
- Has the run around coil system been correctly filled?
- Has the plate heat exchanger been set up?
- Are the environmental conditions for correct use being met?

WARNING!

Risk of explosion from casing leakage!

The unavoidable casing leakage that comes with operation may lead to a potentially explosive atmosphere outside of the air handling unit (zonal dispersion).

If the installation room (i.e. the space in the vicinity of the AHU) has not been defined as an Ex zone, ensure that it is sufficiently ventilated.

6.4 Starting the air handling unit

6.4.1 Before you start the AHU

WARNING!

Risk of explosion!

Before the system can be commissioned, a qualified person or expert has to examine the system to ensure that it complies with the ATEX directive. The result of the examination has to be documented.

6.4.2 Starting

Personnel qualified to start the air handling unit

Only specially trained individuals must start the air handling unit.

Follow the instructions in the operating manual for the air handling unit.

If the unit is not fitted with integral controls, i.e. if the controls have been supplied by others, follow the instructions of the supplier.

Before you switch on the air handling unit, make sure that the following requirements have been met:

- Has the air handling unit been checked for damage?
- Have the transport protection devices been removed?
- Have the filters been inserted?
- Have all inspection access doors and openings been adjusted and closed?
- Have all ducts in the AHU been connected?
- Have the AHU and the connected ducts been tested for any leaks?
- Has the interior of the air handling unit been cleaned?
- Have all drain traps been filled with water?
- Does the supply of power and of operating fluids meet all requirements?
- Has all the safety equipment been installed? Does it work properly?
- Have all the electrical connections been made and secured according to the relevant national standards?
- Have all equipotential bonding measures been installed and checked?
- Has the heating coil/cooling coil been correctly connected and filled?
- Has the centrifugal fan been set up?
- Have the multileaf dampers been set up?

7 Removal and disposal

7.1 Safety notes regarding disassembly and disposal

 **WARNING!**

Risk of explosion!

Ignition sources, such as sparks, open flames or hot surfaces, can lead to explosions in an area with potentially explosive atmospheres.

- Only specially trained personnel must carry out work in an area with potentially explosive atmospheres.
- Get written permission before you start working in an area with potentially explosive atmospheres.
- To remove the potentially explosive atmosphere, purge the air handling unit with fresh air before you open it.
- If you have to carry out work, either ensure that there is no potentially explosive atmosphere, or at least avoid any source of ignition. If you have to work in a zone with potentially explosive atmospheres, use only equipment that has been approved for use in that particular zone.
- If the AHU installation room has not been defined as an Ex zone, the system owner has to ensure sufficient ventilation in the installation room as otherwise normal leakage may result in an explosive atmosphere outside of the AHU (zonal dispersion).

Failure to comply with these safety notes may lead to an explosion.

Incorrect disassembly

 **DANGER!**

Risk to life from incorrect assembly and disassembly!

Incorrect assembly or disassembly can result in risks to life and limb and in environmental hazards.

- Before you start disassembly, professionally disconnect all electrical cables.
 - Only a skilled qualified electrician must disconnect the power supply.
 - Ensure that no voltage is present.
- Before you start disassembly, correctly drain all operating fluids.
 - Disconnect operating fluid pipes and hoses.
 - Ensure that operating fluids are disposed of correctly.
- If you have any questions regarding disassembly, refer to the assembly instructions in this manual.

Pay attention to the component manufacturers' documentation.
- Only trained specialist personnel must remove any components.
- If necessary, use additional personal protective equipment for outdoor installations, e.g. a safety harness.

Improper transport equipment **WARNING!****Risk to life from using improper transport equipment!**

If packages are lifted without adequate transport equipment and if they are not properly secured, they may fall off and lead to fatal injuries.

- Move components only in the position in which they are to be installed.
- Stand clear of suspended loads.
- Do not move additional loads on top of a package.
- Use only the intended lashing points.
- Make sure that no load is imposed on pipes, ducts or cables.
- Use only approved lifting gear and slings that are suitable and sufficient for the load to be carried.
- Do not tie ropes and chains or make knots or place them on sharp edges.
- Use lifting equipment only to lift packages or units, not to push or pull them.
- Ensure that ropes, belts and chains do not twist.
- Ensure that transport equipment has been correctly assembled, fastened and secured before you use it to lift anything.
- Secure all doors, dampers and panels.
- Move packages without any jerky movements and put them down when you leave your workplace.
- Lifting eyes are designed for one-time use only and not for permanently suspending loads.
- Transport tubes are designed for one-time use only and not for permanently suspending loads.

 2.4 'Residual risks' on page 9

Unbalanced loads and centre of gravity **WARNING!****Risk of injury from falling or toppling loads!**

Loads may be unbalanced, i.e. the centre of gravity may not be obvious. If the load is not properly attached to the lifting equipment, it may topple and fall. Falling or toppling loads can cause serious injuries.

- When you use a crane to move loads, ensure that the centre of gravity of the load is directly beneath the crane hook.
- Lift any load carefully and keep an eye on it to see whether it will stay in place. If required, change the lashing point(s).

Crushing hazard. **WARNING!****Crushing hazard from movable parts!**

There is an increased risk of crushing on casing units, doors, panels and components of the device.

- Never reach between moving parts.
- Be careful when carrying out any work.
- Wear protective gloves, safety shoes and a hard hat.

Inspection access doors slamming shut **WARNING!****Risk of crushing from doors slamming shut**

Inspection access doors may slam shut by the wind or if someone pushes them inadvertently, resulting in serious injury to the head and limbs.

- Secure each inspection access door with a hold open device.
- Secure inspection access doors without a hold open device against closing by suitable means.
- Do not reach between the door and door frame.
- Wear protective gloves and a hard hat when you open an inspection access door.

Sharp edges, sharp corners and thin sheet metal parts **CAUTION!****Danger of injury from sharp edges, sharp corners and thin sheet metal parts!**

Sharp edges, sharp corners and thin sheet metal parts of the heat exchanger or of the cooling or heating coil may cause cuts or grazes.

- Be careful when working on these components.
- Wear protective gloves, safety shoes and a hard hat.

 **ENVIRONMENT!****Risk of harm to the environment due to incorrect disposal of goods and packaging!**

Incorrect disposal can harm the environment.

- Have electronic waste, electronic components and operating fluids (refrigerant, compressor oil, lubricants etc.) disposed of by an approved specialist disposal company.

7.2 Disassembly

Personnel:

- HVAC technician
- Skilled qualified electrician

Protective equipment:

- Industrial safety helmet
- Protective clothing
- Hearing protection
- Protective gloves
- Safety shoes

1. ▶ Disconnect electrical cables.
Ensure that no voltage is present.
2. ▶ Remove all operating fluids.
Properly dispose of all operating fluids.
3. ▶ Disconnect operating fluid pipes and hoses.
4. ▶ Open all module connectors and base frame connectors.
5. ▶ Remove the various unit components.
Use suitable transport equipment to move unit components away from the site.

7.3 Disposal

If no return or disposal agreement is in place, any disassembled components should be disposed of by an approved specialist disposal company.

Components that are no longer required should be recycled:

- Scrap the metals.
- Take plastic parts to be recycled.
- Dispose of other components and waste in a suitable manner, i.e. depending on their material properties.

Electrical and electronic components

Electrical and electronic components can contain materials and substances that are hazardous to health and the environment and which must not get into household and commercial waste.

As electrical and electronic components may also contain recyclables (e.g. precious metals), they must be provided for recycling or disposal by a specialist disposal company.

Chemicals

Chemicals (solvents, cleaning agents, operating fluids, etc.) affect the air, soil, water, and human health in various ways. In some cases, valuable substances can be extracted from them.

Chemicals must therefore not get into the air, soil, sewerage system, surface water or groundwater.

Commission an approved specialist disposal company to recover or dispose of chemicals.

Refrigerant R-410A

Refrigerants may contain substances that are toxic and hazardous to the environment, or which release hazardous decomposition products. These must not be released into the environment. Commission a specialist disposal company to dispose of hazardous substances and materials.

Coolant, glycol

Coolants may contain substances that are toxic and pose a hazard to the environment. They must not be released into the environment. Commission a specialist disposal company to dispose of hazardous substances and materials.

Batteries

Battery components are toxic and pose a hazard to the environment. Batteries must not be disposed of with domestic waste. Batteries must only be disposed of by locally approved specialist companies.

Lubricants

Lubricants such as greases and oils contain toxic substances. They must not be released into the environment. Commission a specialist disposal company to dispose of hazardous substances and materials.

Compressor oil

Compressor oil must not enter sewerage systems or bodies of water. Commission a specialist disposal company to dispose of hazardous substances and materials.

8 Glossary

Components (to 2014/34/EU)

Any item essential to the safe functioning of equipment and protective systems but with no autonomous function.

Equipment (to 2014/34/EU)

Machines, apparatus, fixed or mobile devices, control components and instrumentation thereof and detection or prevention systems which, separately or jointly, are intended for the generation, transfer, storage, measurement, control and conversion of energy and/or the processing of material and which are capable of causing an explosion through their own potential sources of ignition.

Exhaust air – EHA

Air that flows from an internal space to the outside.

Explosive atmosphere (to 2014/34/EU)

A mixture with air, under atmospheric conditions, of flammable substances in the form of gases, vapours, mists or dusts in which, after ignition has occurred, combustion spreads to the entire unburned mixture. May also be called 'zone with potentially explosive atmospheres' in this manual.

Extract air – ETA

Air that flows out of a conditioned room.

HVAC technician

HVAC technicians are individuals who have sufficient professional or technical training in the field they are working in to enable them to carry out their assigned duties at the level of responsibility allocated to them and in compliance with the relevant guidelines, safety regulations and instructions. HVAC technicians are individuals who have in-depth knowledge and skills related to HVAC systems; they are also responsible for the professional completion of the work under consideration.

Indoor air – IDA

Air in a conditioned internal space.

ODA – Outdoor air

Untreated air that flows through an inlet into the air handling unit or a building.

Potentially explosive atmosphere (to 2014/34/EU)

An atmosphere which could become explosive due to local and operational conditions. May also be called 'area with potentially explosive atmospheres' in this manual.

Recirculated air – RCA

Extract air that is reconditioned in the air handling unit and supplied to an internal space again.

Secondary air – SEC

Air that is conditioned and then supplied to the same room from which it was extracted.

Skilled qualified electrician

Skilled qualified electricians are individuals who have sufficient professional or technical training, knowledge and actual experience to enable them to work on electrical systems, understand any potential hazards related to the work under consideration, and recognise and avoid any risks involved.

Skilled qualified refrigeration technicians

Skilled qualified refrigeration technicians have been trained in the field of refrigeration engineering, and they know the relevant standards and guidelines. Evidence of the relevant experience claimed must be available. Skilled qualified refrigeration technicians are individuals who have sufficient professional or technical training, knowledge and actual experience to enable them to work on refrigeration systems, understand any potential hazards related to the work under consideration, and recognise and avoid any risks involved.

Supply air – SUP

Air that is supplied to a conditioned internal space; it is also conditioned air that enters an air handling unit.

Transfer air – TRA

Air that flows from one conditioned internal space to another conditioned internal space.

Zone (1999/92/EC, Annex I)

Hazardous places are classified in terms of zones on the basis of the frequency and duration of the occurrence of an explosive atmosphere. May also be called 'zone with potentially explosive atmospheres' in this manual.

9 Index

A

Accident.....	10
Adjusting multileaf dampers.....	51
AHU casing units	
Applying sealing tape.....	29
Assembling AHU casing units for outdoor installation.....	29
Assembling the roof segments.....	29
Assembly.....	27
Attaching the weather hood.....	29
Cover strips for the intermediate frame, fixing.....	29
Fitting base frame plugs.....	29
Installing ducts.....	32
Joining with screws/bolts.....	27
Setup.....	25
AHU components	
Fitting flexible connectors.....	28
Seals, checking.....	25
Air handling unit	
Commissioning.....	44
Electrical connection.....	41
Installing accessories.....	32
Applying sealing tape.....	29
Assembling the roof segments.....	29
Assembly	
Accessories.....	32
AHU casing units for outdoor installation.....	29
Assembling AHU casing units.....	27
Base frame plugs.....	29
Connector.....	28
Ducts.....	32
Intermediate frame, fixing the cover strips.....	29
Roof segments.....	29
Weather hood.....	29
Attaching the weather hood.....	29

C

Commissioning the centrifugal fan.....	47
Condensate drain.....	36
Cooling coil	
Commissioning.....	49
Installing.....	37
Copyright.....	3

D

Defects liability.....	3
Delivery of the air handling unit.....	12
Disposing of packaging.....	20
Drain trap, connecting.....	36

E

Electrical connection.....	41
Electric current.....	9
Environmental protection	
Chemicals.....	56
Electrical and electronic components.....	56

F

Fan.....	10
Filters, inserting.....	48
Fire.....	10
First aid.....	10
Fitting base frame plugs.....	29

H

Hazardous area.....	10
Heating coil	
Commissioning.....	49
Installing.....	37
Height of drain trap.....	35
Hotline.....	3
hydraulic unit.....	39

I

Improper transport equipment.....	13
Initial commissioning.....	44
Adjusting inspection access doors.....	45
Centrifugal fan.....	47
Filters.....	48
Heating coil/cooling coil.....	49
Multileaf dampers.....	51
Plate heat exchanger.....	52
Run around coil system.....	50, 51
Sound attenuator.....	52
Starting.....	53
Inspection access doors	
Leakage.....	45
Installation	
Condensate drain.....	36
Connecting the heating coil/cooling coil.....	37
Connection to the central BMS.....	43
Drain trap, connecting.....	36
Height of drain trap.....	35
Run around coil system.....	38
Installation location, requirements	
Installation room.....	24
Installing	
Plate heat exchanger.....	27
Installing accessories.....	32
Installing ducts.....	32
Intermediate frame, fixing the cover strips.....	29

L				S	
Lashing points.....	15			Service.....	3
Leakage				Setup and assembly.....	22
Inspection access doors.....	45			Sound attenuator.....	52
Limitation of liability.....	3			Specific hazards.....	9
N				Starting.....	53
Noise.....	10			Storage.....	20
Noise insulation.....	25			Suspended loads.....	9
O				Symbols.....	4
Other applicable documentation.....	3			On the packaging.....	12
P				System owner.....	7
Packages				System owner's obligations.....	7
Storage.....	20			T	
Transport.....	14 , 15 , 18			Technical Service.....	3
Unpacking.....	20			Transport	
Personnel.....	7			Crane and eye nuts.....	17
Plate heat exchanger.....	52			Crane and lifting eyes.....	16
Assembly.....	27			Crane and transport tubes.....	18
Q				Delivery.....	12
Qualification.....	7			Delivery check.....	12
R				Forklift or pallet truck.....	14
Removal and disposal.....	55			Transport damage.....	12
Replacement parts.....	11			Transport straps.....	15
Requirements				U	
Assembly.....	26			Unpacking.....	20
Initial commissioning.....	44			V	
Installation.....	34			Vibration, preventing.....	25
Starting.....	53			W	
Requirements for the installation location				Warranty claims.....	3
Foundation of the installation room.....	24			X	
Foundation of the outdoor installation area.....	24			X-CUBE.....	6
Installation room.....	23			X-CUBE components.....	6
Residual risks.....	9				
Run around coil system					
Commissioning.....	50 , 51				
Connection.....	38				

Appendix

A Supplier documents**A.1 Ziehl-Abegg RH..C / ER..C fan**

Name	Data
Designation	Fans
Type	RH..C / ER..C
Number	
Type of manual	Installation manual
Manufacturer	Ziehl-Abegg

Freilaufende Radiallaufräder / Einbauventilatoren

direktgetrieben, mit IEC-Normmotor der Schutzart druckfeste Kapselung Ex de IIC T4 Gb oder druckfeste Kapselung mit Klemmkasten erhöhte Sicherheit Ex de IIC T4 Gb für die Förderung von explosionsfähiger Atmosphäre der Zone 1 Kategorie 2G und Zone 2 Kategorie 3G.

Inhaltsübersicht

Kapitel	Seite
Anwendung	1
Sicherheitshinweise.	2
Transport, Lagerung	3
Laufradeinbau	3
Elektrischer Anschluss.	4
Geräteaufstellung	4
Betriebsbedingungen.	5
Inbetriebnahme.	5
Instandhaltung und Wartung.	6
Reinigung	6
Hersteller	7
Serviceadresse.	7

VENTILATOR-Typenschild
einkleben!

Die Einhaltung der nachfolgenden Vorgaben dient auch der Sicherheit des Produktes. Sollten die angegebenen Hinweise insbesondere zur generellen Sicherheit, Transport, Lagerung, Montage, Betriebsbedingungen, Inbetriebnahme, Instandhaltung, Wartung, Reinigung und Entsorgung / Recycling nicht beachtet werden, kann das Produkt eventuell nicht sicher betrieben werden und kann eine Gefahr für Leib und Leben der Benutzer und dritter Personen darstellen. Abweichungen von den nachfolgenden Vorgaben können daher sowohl zum Verlust der gesetzlichen Sachmängelhaftungsrechte führen als auch zu einer Haftung des Käufers für das durch die Abweichung von den Vorgaben unsicher gewordene Produkt

i Anwendung

RH..C



- ZIEHL-ABEGG - Freilaufende Radiallaufräder der Baureihe **RH..C**, in den lieferbaren Baugrößen **250 bis 1000**, sowie die Gerätebaureihe **ER..C** (Typenbezeichnung siehe Typenschild) in explosionsgeschützter Ausführung **Ex II 2G c IIB T4 mit IEC-Normmotor der Zünd-**

Centrifugal impeller without scroll / Plenum Fans

direct-driven, with IEC standard motor of protection type pressure-proof housing Ex de IIC T4 Gb or pressure-proof housing with terminal box for increased safety Ex de IIC T4 Gb for conveyance of zone 1 category 2G and zone 2 category 3G explosive atmospheres.

Contents

Chapter	Page
Application	1
Safety instructions.	2
Transport, storage.	3
Installing the impeller.	3
Electrical connection	4
Setting up the unit.	4
Operating conditions	5
Start-up	5
Repairs and maintenance	6
Cleaning	6
Manufacturer.	7
Service address	7

Compliance with the following instructions is mandatory to ensure the functionality and safety of the product. If the following instructions given especially but not limited for general safety, transport, storage, mounting, operating conditions, start-up, maintenance, repair, cleaning and disposal / recycling are not observed, the product may not operate safely and may cause a hazard to the life and limb of users and third parties.

Deviations from the following requirements may therefore lead both to the loss of the statutory material defect liability rights and to the liability of the buyer for the product that has become unsafe due to the deviation from the specifications.

i Application

ER..C

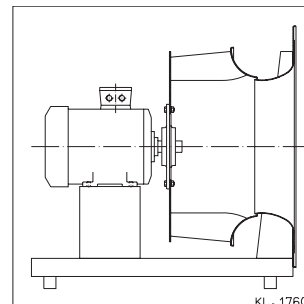

- ZIEHL-ABEGG - Series **RH..C** free running centrifugal impeller, available in frame sizes **250 to 1000**, and the device series **ER..C** (Type designation see rating plate) in explosion-proof version **Ex II 2G c IIB T4 with IEC standard motor protection type Ex de IIC T4 Gb or Ex de IIC T4 Gb** are not ready-for-use products, but are designed

schutzart Ex de IIC T4 Gb oder Ex d IIC T4 Gb sind keine gebrauchsfertigen Produkte, sondern als Komponenten für Klima-, Be- und Entlüftungsanlagen konzipiert. Sie dürfen erst betrieben werden, wenn sie ihrer Bestimmung entsprechend eingebaut sind und die Sicherheit durch Schutzeinrichtungen nach DIN EN ISO 13857 / EN 60529 und die nach EN 14986 erforderlichen baulichen Explosionsschutzmaßnahmen sichergestellt ist.

- Der Anlagenbauer ist für die Abdichtung der Anlage verantwortlich.
- Die Ventilatoren erfüllen hinsichtlich der Werkstoffwahl durch besondere Schutzmaßnahmen im Bereich möglicher Berührungsflächen zwischen rotierenden und stehenden Bauteilen (Lüfterraddeckscheibe / Einströmdüse) die Anforderungen der Norm EN 14986. Für das rotierende Teil (Lüfterraddeckscheibe) wird als Werkstoff „Stahl beschichtet“ eingesetzt. Für die Auswahl des Werkstoffs der feststehenden Peripherieteile ist, bei Bezug des Lüfterrades ohne ZIEHL-ABEGG-Einströmdüse, der Anlagenbauer verantwortlich. Es dürfen nur Werkstoffpaarungen nach EN 14986 eingesetzt werden.



Sicherheitshinweise

- Die Laufräder sind nur zur Förderung von Luft oder explosionsfähiger Atmosphäre der Zone 1 Kategorie 2G und Zone 2 Kategorie 3G bestimmt. Die Förderung von Feststoffen oder Feststoffanteilen im Fördermedium ist nicht zulässig.
- Betreiben Sie den Ventilator nur nach seiner bestimmungsgemäßen Verwendung und nur bis zur **max. zulässigen Betriebsdrehzahl** gemäß Angaben auf dem Ventilator-/Laufrad-Typenschild. Ein Überschreiten der max. zul. Betriebsdrehzahl führt als Folge der hohen kinetischen Energie (Masse x Drehzahl) zu einer Gefährdungssituation. **Das Laufrad kann bersten - Lebensgefahr!** Die max. zulässigen Betriebsdaten auf dem Typenschild gelten für eine Luftdichte $\rho = 1,2 \text{ kg/m}^3$.
- Freilaufende Laufräder sowie die Gerätebaureihe **ER...** dürfen mit Frequenzumrichter nur dann betrieben werden, wenn ein Antriebsmotor der Zündschutzart „**Druckfeste Kapselung Ex de IIC oder Ex d IIC**“ verwendet wird.
- Die Angabe der Temperaturklasse auf dem EX-Prüfschild (Motor) muss mit der Temperaturklasse des möglicherweise auftretenden brennbaren Gases übereinstimmen.
- Montage und elektrische Installation darf nur durch geeignetes Fachpersonal, das die **einschlägigen Vorschriften** beachtet, vorgenommen werden!
- Jedem Motor muss ein Motorschutzschalter vorgeschaltet sein. Beachten Sie hierzu die Angaben des Motorherstellers.
- Wicklungsüberwachung durch Kaltleiter für Abschaltung am Umrichter. Zur Schutzeinrichtung wird ein Auslösegerät mit Kennzeichen II (2) G benötigt.
- Bei Drehzahlsteuerung durch Frequenzumrichter ist sicherzustellen, dass die max. zul. Drehzahl nicht durch eine Fehlfunktion des Frequenzumrichters überschritten wird.
- Bei Betrieb mit Frequenzumrichter ist eine Übermodulation nicht zulässig. Lüfterrad kann bersten - **Lebensgefahr!**
- Bezüglich Drehzahlregelung mit Frequenzumrichter sind die Sicherheitshinweise und Empfehlungen gemäß der Betriebsanleitung des Motorherstellers einzuhalten. Dies gilt auch in Bezug auf Motoreinbau, elektrischen Anschluss und Wartung.
- Beachten Sie die Einbau- und Sicherheitshinweise zu den verschiedenen Ventilatorbauformen. Nichtbeachtung oder Missbrauch kann zu körperlichen Schäden oder Beschädigung des Ventilators und zur Explosion einer zündfähigen Gas-Luftatmosphäre führen - **Lebensgefahr.**
- Beachten Sie die Hinweise in der Betriebsanleitung des Motorherstellers, die Bestandteil des Lieferumfangs ist.
- Wird der Ventilator frei ansaugend oder frei ausblasend eingesetzt, ist zu prüfen, ob die Sicherheitsabstände gemäß **DIN EN ISO 13857 / EN 60529** eingehalten werden.
- Die Einhaltung der Norm DIN EN ISO 13857 / EN 60529 bezieht sich nur auf den montierten Berührschutz, sofern dieser zum Lieferumfang gehört.
- Achten Sie insbesondere saugseitig auf ausreichend bemessenen Sicherheitsabstand, da durch die Sogwirkung des Ventilators Kleidung, Gliedmaßen oder bei größeren Ventilatoren auch Personen angesaugt werden können.

as components for air-conditioning and ventilation plants. They may only then be operated when they are installed in accordance with their intended use and safety has been ensured through protective devices in accordance with DIN EN ISO 13857 / EN 60529 and the required structural explosion-protective measures in accordance with the EN 14986.

- The system constructor is responsible for the sealing of the system.
- Regarding the choice of materials, the fans fulfill the requirements of the EN 14986 standard through special protective measures in the area of possible accidental contact between the rotating and stationary component parts (impeller). „Coated steel“ is used as the material for the rotating part (impeller shroud). The system constructor is responsible for the selection of the material for the stationary periphery parts when the impeller is purchased without ZIEHL-ABEGG inlet rings. Only mating materials in accordance with the EN 14986 may be utilized.



Safety instructions

- The impellers are only intended for the conveyance of air or zone 1 category 2G and zone 2 category 3G explosive atmospheres. The conveyance of solid matter or solids content in the conveyance medium handled is not permitted.
- Only operate the fan according to the intended application, and only up to the **maximum permissible speed** given in the information on the fan/impeller rating plate. Exceeding the maximum permissible speed leads, as a result of the high kinetic energy (mass x rotation rate), to a hazardous situation. **The impeller can burst - lethal hazard!** The maximum permissible operating data given on the rating plate is valid at an air density $\rho = 1.2 \text{ kg/m}^3$.
- Impellers without housing/plug fans as well as the **ER...** device series may only then be operated with a frequency converter if a drive motor of the **"Ex de IIC or Ex d IIC pressure-proof housing"** ignition protection type is utilized.
- The data concerning the temperature class on the EX-rating plate (motor) must coincide with the temperature class of any possibly occurring combustible gasses.
- Mounting and electrical installation may only be carried out by trained specialized personnel who observe the **relevant regulations!**
- A protective motor switch must be connected before each motor. Please comply with the motor manufacturer's instructions.
- Winding monitoring through PTC thermistors for disconnection at the converter. A triggering device with the II (2) G mark is needed as a safeguard.
- In case of speed control through a frequency converter, it must be ensured that the max. permissible speed cannot be exceeded due to any frequency converter malfunction.
- When in operation with a frequency converter, no over-modulation is allowed. The fan wheel may burst – **danger to life!**
- With regard to speed regulation with frequency converters, the safety instructions and recommendations are to be maintained in accordance with the motor manufacturer's operating instructions. This also applies to motor installation, electrical connections, and servicing.
- Observe the installation and safety instructions applicable to the various fan designs. Non-observance or misuse can lead to bodily harm or damage to the fan and to the explosion of ignitable gas-air mixtures - **Danger of death.**
- Observe the notes in the motor manufacturer's operating instructions, which form part of the supply.
- If a fan is utilized as a free inlet or free discharge type, verify that the required clearance based on **DIN EN ISO 13857 / EN 60529** is maintained.
- The maintenance of the standard DIN EN ISO 13857 / EN 60529 relates only to the installed accidental contact protection, provided that it is part of the scope of delivery.
- Pay special attention that there is sufficiently dimensioned safety clearance on the inlet side, as clothes, limbs, or, in the case of large fans, even people can be sucked in due to the fan's suction power.

- Wenn durch die Geräte- oder Anlagenkonstruktion das Ansaugen oder Hereinfallen größerer Teile in den Laufbereich nicht ausgeschlossen werden kann - **Gefahr der Explosion einer zündfähigen Gas-Luftatmosphäre** - ist saugseitig ein Schutzgitter zwingend erforderlich.
- Blockieren oder Abbremsen des Ventilators durch z. B. Hineinstecken von Gegenständen ist untersagt. Dies führt zu heißen Oberflächen und Beschädigungen am Laufrad.
- Ein Restrisiko durch Fehlverhalten, Fehlfunktion oder Einwirken höherer Gewalt beim Betreiben des Laufrades kann nicht völlig ausgeschlossen werden. Der Planer oder Erbauer der Anlage muss durch geeignete Sicherheitsmaßnahmen nach DIN EN ISO 13857 / EN 60529, z. B. Schutzeinrichtungen, verhindern, dass eine Gefährdungssituation entstehen kann.
- Diese Montageanleitung ist Teil des Produktes und als solche zugänglich aufzubewahren.



Transport, Lagerung

Bei der Handhabung Sicherheitsschuhe und Schutzhandschuhe benutzen!

- Radiallaufräder oder Einbauventilatoren ER..C werden in der Regel auf Europaletten geliefert und können mittels Hubwagen transportiert werden.
- Bei Transport mit Hebezeugen:
 - **Bauform RH..C ohne Motor:** Hebeband mit ausreichender Traglast um eine Laufradschaufel herumlegen. Beachten Sie die Gewichtsangabe auf dem Typenschild (Rückseite der Laufradbodenscheibe). Verwenden Sie nur ein Hebeband, das geeignet ist, scharfkantige Lasten zu tragen.
 - **Bauform ER..C:** Ventilatoreinheit darf nur mit geeignetem Hebezeug (Lasttraverse) angehoben und transportiert werden. Auf ausreichende Seil- bzw. Kettenlänge ist zu achten.
 - **Achtung: Anordnung der Lasttraverse quer zur Motorachse. Auf ausreichende Breite der Lasttraverse achten. Kette bzw. Seil darf das Lüfterrad beim Anheben nicht berühren! Stellen Sie sich auf keinen Fall unter den schwebenden Ventilator, da im Falle eines Defektes am Transportmittel Lebensgefahr besteht. Beachten Sie unbedingt immer die Gewichtsangaben auf dem Ventilator-Typenschild und die zul. Traglasten des Transportmittels.**
- Vermeiden Sie Schläge und Stöße, besonders bei auf Geräten aufgebauten Ventilatoren.
- Bei Beschädigungen umgehend den Spediteur benachrichtigen.
- Lagern Sie den Ventilator in trockener, staub- und schwingungsfreier Umgebung.
- Vermeiden Sie zu lange Lagerzeiträume. Beachten Sie hierzu die Hinweise des Motorherstellers.



Laufradeinbau

- **Laufräder mit Festnabe**
 - Das Laufrad wird mittels Festnabe mit dem Wellenende des Antriebsmotors verbunden.
 - Montage: Alle blanken Oberflächen (Wellenende, Nabenbohrung) leicht befeuchten. Laufrad mit Nabe (1) bis auf Wellenschulter (2) aufziehen (Übergangspassung). Bei entsprechendem Gewicht mit Hebezeug sichern. Axiale Wellensicherung mittels Schraube (3) und Scheibe (4) vorsehen. Anzugsmomente nach Tabelle einhalten. Die Schraube (3) ist mit einer Sicherungsscheibe (z. B. Sperrkant- oder Kontaktscheibe) zu sichern. Bei Motoren ab BG132 (WellenØ 38) ist nach Norm EN 14986 eine Sonderscheibe mit Schrauben (5) zur zusätzlichen Sicherung angebracht. Anzugsmomente nach Tabelle einhalten.
 - Demontage: Axiale Schraubensicherung lösen und Laufrad mit Nabe mittels geeigneter Abziehvorrichtung abziehen (bei entsprechendem Gewicht mit Hebezeug sichern). Bei Motoren ab BG132 muss die zusätzliche axiale Wellensicherung (5) ebenfalls gelöst werden.



Transport, storage

Wear safety shoes and gloves for handling!

- Centrifugal impellers and ER..C plug fans are generally delivered on Euro pallets and can be transported using lift trucks.
- When transporting using hoists/cranes:
 - **RH..C design without motor:** Wrap an impeller blade using a sling band with a sufficient amount of ultimate load. Observe the weight data on the identification plate (back of the impeller base plate). Use only sling bands that are suitable for carrying sharp-edged loads.
 - **ER..C design:** Fan unit may only be lifted and transported using a suitable hoisting device (load spreader). Ensure there is sufficient cable or chain length.
 - **Caution: Arrange the lifting beam transverse to the motor axis. Ensure that the lifting beam is sufficiently wide. Chain or cable must not touch the fan impeller during lifting! Never stand under the swinging fan, since life can be at risk in the event of a defect in the transporter. Make sure that the weight information on the fan rating plate and the permissible loads of the transporter are always observed.**
- Avoid impacts and collisions, especially on fans set-up on devices.
- In the event of damage inform the carrying agent immediately.
- Store the fan in a dry, dust- and vibration-free environment.
- Avoid excessive storage times. Please refer to the manufacturer's motor information on this.



Installing the impeller

- **Impellers with fixed hub**
 - The impeller is connected to the shaft end of the drive motor using a fixed hub.
 - Installation: Lightly lubricate all bare surfaces (shaft ends, hub holes). Pull the impeller with the hub (1) up to the shaft shoulder (5) (transitional fit). Secure with the hoisting device with corresponding weight. Secure the axial shaft-locking device using the screw (3) and washer (4). Maintain the torque in accordance with the table. The screw (3) is to be secured using a locking washer (e.g. square taper washer or contact washer). For motors starting from BG132 (shaft Ø 38), a special washer with screws (5) is to be attached as an additional safeguard in accordance with EN 14986 standard. Maintain the torque in accordance with the table.
 - Disassembly: Release the axial screw connection and pull off the impeller with the hub using a suitable pulling unit (secure with hoisting device at the corresponding weight). For motors starting from BG132, the additional axial shaft-locking device (5) must be released also.

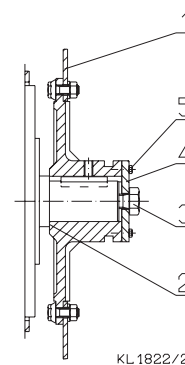
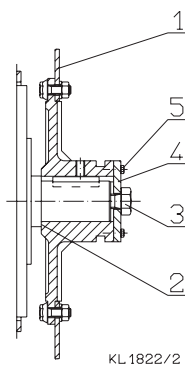

FK 8.8	M4	M5	M6	M8	M10	M12
MA	2,8 Nm	5,5 Nm	9,5 Nm	23 Nm	46 Nm	79 Nm

SC 8.8	M4	M5	M6	M8	M10	M12
MA	2,8 Nm	5,5 Nm	9.5 Nm	23 Nm	46 Nm	79 Nm

- Bei Einhaltung der Werkstoffpaarung müssen folgende Mindestspalte eingehalten werden: zwischen rotierenden und stehenden Teilen (Lauftraddescheibe / Einströmdüse bzw. Druckentnahmenippel) darf der Mindestspalt (s) nicht kleiner als 1 % des maßgeblichen Kontaktdurchmessers, aber nicht weniger als 2 mm betragen.

- *The following minimum gap must be maintained during compliance of materials mating: between the rotating and stationary parts (impeller shroud / inlet ring or pressure release nipple), the minimum gap (s) must not be smaller than 1 % of the relevant contact diameter, but must not be less than 2 mm.*

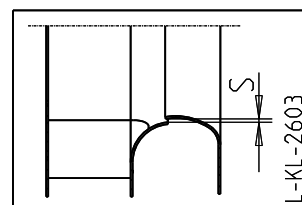
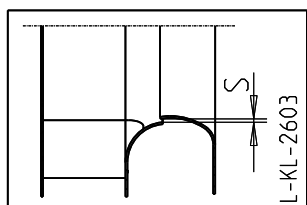

- Vor- bzw. nachgeschaltete Bauteile oder solche, die unmittelbar im Luftstrom liegen, dürfen keine ungeschützten Aluminium- oder Stahloberflächen aufweisen. Erforderlich ist eine Lackierung oder Kunststoffbeschichtung, welche mindestens Gitterschnitt-Kennwert 2 nach DIN EN ISO 2409 erfüllt. Der Oberflächenschutz soll verhindern, dass es zur Bildung von Rost oder Ablagerung von Eisenoxyd oder kleineren Rostpartikeln kommt, welche in Verbindung mit Aluminium und dem Auftreffen von Partikeln mit hoher Luftgeschwindigkeit zu einer chemischen Reaktion (aluminotherm. Reaktion) und somit zur Zündung einer explosionsfähigen Gas-Luftatmosphäre führt.

- *Up and downstream components or those that lie directly in the airflow must not have any unprotected aluminum or steel surfaces. A paint finish or plastic coating that at least fulfills the crosscut test parameter 2 in accordance with DIN EN ISO 2409 is required. The surface protection is to prevent the formation of rust or sedimentary deposition of red oxide or small rust particles, which in connection with aluminum and the emergence of particles with high airflow velocity lead to a chemical reaction (aluminothermal reaction) and thus to ignition of an explosive gas-air atmosphere.*



Elektrischer Anschluss

- Darf nur von technisch ausgebildetem Fachpersonal (DIN EN 50 110, IEC 364) vorgenommen werden.
- Nur Kabel verwenden, die eine dauerhafte Dichtigkeit in Kabelverschraubungen gewährleisten (druckfest-formstabiler, zentrisch-runder Mantel; z. B. mittels Zwickelfüllung!)
- Der Ventilator darf nur an Stromkreise angeschlossen werden, die mit einem allpolig trennenden Schalter abschaltbar sind.
- Beachten Sie unbedingt die Sicherheits- und Inbetriebnahmehinweise des Motorherstellers, sowie die im Motor-Klemmenkasten befindlichen Schaltbilder.
- Vor dem elektrischen Anschluss des Motors die Anschlussdaten mit den Angaben auf dem Motortypenschild vergleichen.



Electrical connection

- *May only be undertaken by technically trained personnel (DIN EN 50 110, IEC 364).*
- *Only use lines which can guarantee a permanent seal around the cable glands (pressure-resistant, dimensionally-stable, round-centred jacket; e.g. by means of gusset filling)!*
- *Connect fan only to electrical circuits that can be disconnected with an all-pole isolating switch.*
- *Ensure that attention is paid to the motor manufacturer's safety and commissioning information and the circuit diagrams in the motor terminal box.*
- *Before making the electrical motor connections, compare the connection specifications with the specifications on the motor identification plate.*



Geräteaufstellung

Bei der Handhabung Sicherheitsschuhe und Schutzhandschuhe benutzen!

- Sicherheitshinweise beachten!
- Um die Übertragung störender Schwingungen zu vermeiden, wird eine Körperschallentkopplung des kompletten Einbauventilators empfohlen. (Feder- bzw. Dämpfungselemente sind nicht Bestandteil des serienmäßigen Lieferumfangs). Die Zuordnung der Abstandmaße der Federdämpfer, je nachdem, ob der Ventilator mit oder ohne Zubehör ausgestattet ist, kann unserer Homepage



Setting up the unit

Wear safety shoes and gloves for handling!

- *Observe the safety information!*
- *In order to avoid transmitting disturbing vibrations, it is recommended that a means of decoupling the structure borne noise of the complete built-in fan should be used. (Spring or attenuation components are not part of the standard supply). The allocation of the distance between the spring suspensions, depending on whether the fan is fitted with accessories or not, can be found on our homepage at www.ziehl-abegg.de in the Download section - Ventilation and Control Technology.*

unter www.ziehl-abegg.de im Bereich Download - Luft- und Regeltechnik entnommen werden.

- **Achtung: Alle Auflagepunkte müssen betriebssicher mit dem Fundament verbunden sein. Bei nicht ausreichender Befestigung besteht Gefahr durch Kippen des Ventilators.**
- Auf ausreichende saug- und druckseitige Abstände achten.
- Aufstellung im Freien nur, wenn in den Bestellunterlagen ausdrücklich vermerkt und bestätigt. Bei längeren Stillstandszeiten in feuchter Umgebung besteht die Gefahr von Lagerschäden. Korrosion durch entsprechende Schutzmaßnahmen vermeiden. Eine Überdachung ist erforderlich.
- Eigenmächtige Veränderungen/Umbauten am Ventilator sind nicht zulässig - Sicherheitsrisiko.
- Werden Gefährdungen durch Blitzschlag festgestellt, müssen die Anlagen durch geeignete Blitzschutzmaßnahmen geschützt werden.
- Anlagen müssen in ausreichendem Sicherheitsabstand zu Sendeanlagen oder durch geeignete Abschirmung geschützt werden.
- ER-Ventilatoren dürfen nur in Einbaulage H (Ventilator stehend, Motorwelle horizontal) betrieben werden!
- Das Demontieren bzw. das Anbringen von Bauteilen am Ventilator bzw. Laufrad führt zum Erlöschen der Garantieleistung! Ausnahme: Der Klemmkastendeckel darf zum Auflegen der Anschlusskabel von technisch ausgebildetem Fachpersonal (DIN EN 50110, IEC 364) geöffnet werden. Am Klemmkasten dürfen geeignete Kabelverschraubungen angebracht werden.

Zubehör:

- Als Zubehör können Schutzgitter, Federdämpfer und Gewebekompensatoren bezogen werden. Beim Einbau bzw. Anbau dieser Elemente ist der Anlagebauer dafür verantwortlich die Zubehörteile zu erten.



Betriebsbedingungen

- Beachten Sie die Angaben des Motorherstellers.
- Ein Überschreiten der max. zul. Betriebsdrehzahl (Ventilator/Laufrad-Typenschild) ist nicht zulässig, siehe Sicherheitshinweise. Die max. zulässige Betriebsdrehzahl gilt für Dauerbetrieb S1. Hohe Schalthäufigkeit ist zu vermeiden. Anlauf über Y/D-Schaltung. Ventilator nicht im Resonanzbereich des Laufrades betreiben - Gefahr durch Dauerbruch.
- Bei Betrieb mit Frequenzumrichter ist eine Übermodulation nicht zulässig. Lüfterrad kann bersten - **Lebensgefahr!**
- A-bewerteter Schallleistungspegel größer 80dB(A) möglich, siehe Produktkatalog.



Inbetriebnahme

- Vor Erstinbetriebnahme prüfen:
 - Hinweise des Motorherstellers zur Inbetriebnahme berücksichtigt?
 - Ist der Motorschutz richtig eingestellt? Polumschaltbare Motoren benötigen für jede Polzahl einen eigenen Schalter. Bei Dreieck-Schaltung muss ein Überlastschutz mit Phasenausfallschutz vorgesehen werden.
 - Einbau und elektrische Installation fachgerecht abgeschlossen?
 - Eventuell vorhandene Montagerückstände und Fremdkörper aus dem Laufrad- und Ansaugbereich entfernt?
- Der Ventilator ist nach dem Einbau auf mechanische Schwingungen zu überprüfen. Ist die Schwingstärke des Ventilators größer als 2,8 mm/s (gemessen am Lager Schild des laufradseitigen Motorlagers), muss das Laufrad von Fachpersonal überprüft und gegebenenfalls nachgewuchtet werden.
- Inbetriebnahme darf erst erfolgen, wenn alle Sicherheitshinweise überprüft und eine Gefährdung ausgeschlossen ist.
 - Stromaufnahme prüfen! **Ist die Stromaufnahme höher als auf dem Motor-Leistungsschild angegeben, ist der Ventilator sofort außer Betrieb zu setzen.**
 - Drehrichtung kontrollieren (Drehrichtungspfeil auf Laufradbodenscheibe bzw. am Ventilatorgehäuse)
 - Auf ruhigen, schwingungsarmen Lauf achten.

- **Caution: All contact points must be fixed securely to the base. If the fixing is inadequate there is a risk of the fan overturning.**
- Ensure adequate clearance on suction and pressure sides.

- Erect in the open air only if this is expressly mentioned and confirmed in the ordering information. There is a risk of damage to the bearings if the fan remains stopped in a moist environment. Avoid corrosion by suitable protective measures. Roofing is required.
- Modifications/conversions to the fan undertaken by the operator are not permissible - safety hazard.
- If hazards from lightning strikes have been ascertained, the system must be protected through the use of suitable lightning protection measures.
- Systems must be sufficiently separated from transmitting installations or be protected through suitable shielding.
- ER fans may only be operated in installation position H (fan upright, motor shaft horizontal)!
- Dismantling and attaching components to the fan or impeller results in expiration of the warranty! Exception: the terminal-box cover may be opened so that technically trained qualified-persons (DIN EN 50110, IEC 364) can attach the connection cable. Suitable threaded cable-connections may be attached to the terminal box.

Accessories:

- Guard grills, spring suspensions, and fabric expansion joints can be ordered as accessories. During the installation or addition of these elements, the system constructor is responsible for grounding the accessory components.



Operating conditions

- Observe the motor manufacturer's instructions.
- Exceeding the max. permissible operating speed (fan / impeller rating plate) is not permissible; see safety instructions. The max. permissible operating speed applies to continuous operation S1. High switching frequencies are to be avoided. Start-up via Y/D connection. Do not operate the fan in the resonance range of the impeller - danger through fatigue fracture.
- When in operation with a frequency converter, no overmodulation is allowed. The fan wheel may burst – **danger to life!**
- A-rated sound power levels of over 80 dB(A) are possible, see product catalogue.



Start-up

- Before first-time start-up, check the following:
 - Account has been taken of the motor manufacturer's information?
 - Ensure that the motor protection is correctly set? Pole-changing motors need a separate switch for each number of poles. An excess-current switch with phase monitor must be provided for delta connections.
 - Installation and electrical connection have been properly completed?
 - All leftover installation materials and other foreign materials have been removed from the fan cavity.
- After installation, check the fan for mechanical oscillations. If the amount of fan oscillation is larger than 2.8 mm/s, (measured on the end plate of the impeller side of the motor bearing), the impeller must be examined by specialists and, if necessary, rebalanced.
- Commissioning may only take place if all safety instructions have been checked and danger can be excluded.
 - Check the current consumption! **If the current consumption is higher than that stated on the motor rating plate, the fan must be disconnected immediately.**
 - Check the direction of rotation (the rotation direction arrow is on the impeller base plate or on the fan housing)
 - Watch out for smooth, vibration free motion.



Instandhaltung und Wartung

- Der Anlagenbauer muss eine leichte Zugänglichkeit für Reinigungs- und Inspektionsarbeiten ermöglichen.
- **Bei der Handhabung Sicherheitsschuhe und Schutzhandschuhe benutzen!**
- Überprüfung des Ventilators auf mechanische Schwingungen gemäß ISO 14694. Empfehlung: alle 6 Monate. Die max. zul. Schwingstärke beträgt 2,8 mm/s (gemessen am Lagerschild des lauffradseitigen Motorlagers, oder gem. den speziellen Vereinbarungen mit dem Kunden).
- Je nach Einsatzbereich und Fördermedium unterliegen Laufrad und Gehäuse einem natürlichem Verschleiß. Ablagerungen am Laufrad können zur Unwucht und damit zu Schäden (Gefahr eines Dauerbruchs) führen.
 - Laufrad kann bersten - Lebensgefahr!
 - Beachten Sie die Angaben des Motorherstellers zur Instandhaltung und Wartung.
- Instandsetzungsarbeiten nur durch ausgebildetes Fachpersonal vornehmen lassen.
- **Bei allen Instandsetzungs- und Wartungsarbeiten:**
 - Sicherheits- und Arbeitsvorschriften (DIN EN 50 110, IEC 364) beachten.
 - Ventilatorlaufrad steht still!
 - Stromkreis unterbrochen und gegen Wiedereinschalten gesichert.
 - Bei Betrieb über Frequenzumrichter Wartezeit nach dem Freischalten beachten - siehe Betriebsanleitung des Herstellers bezüglich Entladungszeit der Kondensatoren.
 - Spannungsfreiheit feststellen.
 - Keine Wartungsarbeiten am laufenden Ventilator!
 - Halten Sie die Luftwege des Ventilators frei - Gefahr durch herausfliegende Gegenstände!
 - Flügel nicht verbiegen - Unwucht!
 - Achten Sie auf untypische Laufgeräusche!
- Die Betriebsmittel in explosionsgeschützter Ausführung dürfen weder geöffnet noch repariert werden. Ein Lagerwechsel von Kunden oder vom normalen Servicefachmann ist ebenfalls nicht zugelassen.
- Nach Laufraddemontage und Wiedermontage ist es zwingend erforderlich, die gesamte rotierende Einheit nach DIN ISO 1940-1 neu auszuwuchten.
- Bei allen anderen Schäden (z.B. Wicklungsschäden) wenden Sie sich bitte an unsere Serviceabteilung.
- Laufrad, insbesondere Schweißnähte, auf eventuelle Rissbildung überprüfen.
- ZIEHL-ABEGG Atex-Ventilatoren / Motoren sind ganz oder teilweise mit antistatischer, ableitfähiger Lackierung oder Beschichtung versehen. Ein Nachlackieren kann zu gefährlichen statischen Aufladungen führen und ist daher nicht zulässig.



Reinigung

- Regelmäßige Inspektion, ggf. mit Reinigung erforderlich um Unwucht durch Verschmutzung zu vermeiden.
 - Durchströmungsbereich des Ventilators säubern.
- Achten Sie auf schwingungsarmen Lauf.
- Wartungsintervalle je nach Verschmutzungsgrad des Laufrades.
- Der komplette Ventilator darf mit einem feuchten Putztuch gereinigt werden.
- Zur Reinigung dürfen keine aggressiven, lacklösenden Reinigungsmittel verwendet werden.
- **Verwenden Sie keinesfalls einen Hochdruckreiniger oder Strahlwasser zur Reinigung - schon gar nicht bei laufendem Ventilator.**
- Wenn Wasser in den Motor eingedrungen ist:
 - Vor erneutem Einsatz Wicklung des Motors trocknen.
 - Ex-geschützte Motoren dürfen weder geöffnet noch repariert werden. Wenn ein Ex-geschützter Motor Fehler aufweist, ist er unbedingt zum Hersteller / Lieferant zurückzuschicken, und ein neuer Ersatzmotor ist anzufordern.
- **Nassreinigung unter Spannung kann zum Stromschlag führen - Lebensgefahr!**



Repairs and maintenance

- *The system constructor must enable easy access for cleaning and inspection work.*
- **Wear safety shoes and gloves for handling!**
- *Check the fan for mechanical oscillations in accordance with ISO 14694. Recommendation: every six months. The max. permissible vibration severity is 2.8 mm/s (measured on the end shield of the impeller side of the motor bearing or according to the special service agreement with the customer).*
- *Depending on the use and the medium in which it operates, the impeller and housing are subject to normal wear. Deposits on the impeller can lead to imbalance and hence to damage (risk of fatigue fracture)*
 - *The impeller can disintegrate - lethal hazard!*
 - *Observe the motor manufacturer's instructions concerning maintenance and service.*
- *Allow maintenance work to be carried out by trained specialists only.*
- **For all repair and maintenance work:**
 - *Observe the safety and labour regulations (DIN EN 50 110, IEC 364).*
 - *The fan impeller stopped!*
 - *Open the electrical circuit and secure against being switched back on.*
 - *When operating by means of frequency converter, ensure that the waiting time is maintained after safety disconnection - see manufacturer's operating instructions regarding capacitor discharge time.*
 - *Verify the absence of voltage.*
 - *No maintenance work at running fan!*
 - *Keep the airways of the fan free- danger because of objects dropping out!*
 - *Do not deform the blades - out-of balance!*
 - *Take note of abnormal operating noise!*
- *The equipment in explosion-proof version must neither be opened nor repaired. Bearing changes are also not permitted by the customer or normal service technician.*
- *After dismantling and reinstalling an impeller, the entire rotating unit must be rebalanced in accordance with DIN ISO 21940-11*
- *Please contact our service department about any other damage (e.g. winding damage).*
- *Check the impeller, in particular the weld-seams, for possible cracks.*
- *ZIEHL-ABEGG Atex-fans / motors are completely or partly covered by antistatic painting or coating, which is able to deviate electric charges. A repaint may lead to dangerous static charges and is therefore not allowed.*



Cleaning

- *Regular inspection, and cleaning is necessary to prevent imbalance due to ingress of dirt.*
 - *Clean the fans's flow area.*
- *Watch out for vibration free motion.*
- *Maintenance interval in accordance with the degree of contamination of the impeller!*
- *You can clean the entire fan with a moist cloth.*
- *Do not use any aggressive, paint solvent cleaning agents when cleaning.*
- **Never use a high-pressure cleaner or water-spray for cleaning - particularly when the ventilator is running.**
- *If water enters the motor:*
 - *Dry off the motor winding before using it again.*
 - *Explosion-proof motors must neither be opened nor repaired. If an explosion-proof motor has defects, it is absolutely essential to send it back to the manufacturer / supplier requesting a new replacement motor.*
- **Wet cleaning under voltage may lead to an electric shock - danger to life!**

CE Hersteller

Unsere Produkte sind nach den einschlägigen internationalen Vorschriften gefertigt (Auflistung und Ausgabestände siehe EG-Einbauerklärung und EU-Konformitätserklärung). Haben Sie Fragen zur Verwendung unserer Produkte oder planen Sie spezielle Anwendungen, wenden Sie sich bitte an:

ZIEHL-ABEGG SE
Heinz-Ziehl-Straße
D-74653 Künzelsau
Tel. 07940/16-0
Fax 07940/16-300
info@ziehl-abegg.de

Serviceadresse

Länderspezifische Serviceadressen siehe Homepage unter www.ziehl-abegg.com

CE Manufacturer:

Our products are manufactured in compliance with applicable international standards and regulations (listing and relevant version see EC Declaration of Incorporation and EC Declaration of Conformity).

If you have any questions about how to use our products or if you are planning special applications, please contact:

ZIEHL-ABEGG SE
Heinz-Ziehl-Straße
D-74653 Künzelsau
Phone 07940/16-0
Fax 07940/16-300
info@ziehl-abegg.de

Service address

Please refer to the homepage at www.ziehl-abegg.com for a list of our subsidiaries worldwide.

EC Declaration of Incorporation

- Translation -
(english)

ZA87ex-GB 1831 Index 006

as defined by the EC Machinery Directive 2006/42/EC, Annex II B

The design of the incomplete machine:

- External rotor motor for explosion-hazardous areas, type of protection "nA" / "ec" or "e" / "eb" MK..
- Axial fan for explosion-hazardous areas, type of protection "c" / "h", with external rotor motor for explosion-hazardous areas, type of protection "nA" / "ec" or "e" / "eb" FB..
- Centrifugal fan for potentially explosive areas, ignition protection class "c" / "h" with external rotor motor, ignition protection class "nA" / "ec" or ignition protection class "e" / "eb" for RE.., RH.
- Centrifugal fan for explosion-hazardous areas, type of protection "c" / "h", with internal rotor motor for explosion-hazardous areas, type of protection "tc" RH.., GR..
- Centrifugal fan for explosion-hazardous areas, type of protection "c" / "h", with internal rotor motor for explosion-hazardous areas, type of protection "d" / "db" ER..
- Centrifugal fan for explosion-hazardous areas, type of protection "c" / "h", with internal rotor motor for explosion-hazardous areas, type of protection "nA" / "ec" GR.., RG..
- Centrifugal fan for explosion-hazardous areas, type of protection "c" / "h", with internal rotor motor for explosion-hazardous areas, type of protection "tc" GR.., RG..

Motor type:

- Asynchronous external or internal rotor motor
- Electronically commutated internal rotor motor (with integrated EC controller)

complies with the requirements in Appendix I, Articles 1.1.2, 1.1.5, 1.4.1, 1.5.1, 1.5.7 in EC Machinery Directive 2006/42/EC.

The manufacturer is the

ZIEHL-ABEGG SE
Heinz-Ziehl-Strasse
D-74653 Künzelsau

The following harmonised standards have been used:

EN 1127-1:2011	Explosive atmospheres - Explosion protection - Part 1: Fundamentals and methodology
EN 60204-1:2006	Safety of machinery; electrical equipment of machines; Part 1: General requirements
EN ISO 12100:2010	Safety of machinery; basic concepts, general principles for design
EN ISO 13857:2008	Safety of machinery; safety distances to prevent danger zones being reached by the upper limbs

Note: The maintenance of the EN1-ISO 13857:2008 relates only to the installed accidental contact protection, r2-provided that it is part of the scope of delivery.

The specific technical documentation in accordance with Appendix VII B has been written and is available in its entirety.

The person authorised for compiling the specific technical documentation is: Dr. W. Angelis, address see above.

The specific documentation will be transmitted to the official authorities on justified request. The transmission can be electronic, on data carriers or on paper. All industrial property rights remain with the above-mentioned manufacturer.

It is prohibited to commission this incomplete machine until it has been secured that the machine into which it was incorporated complies with the stipulations of the EC Machinery Directive.

Künzelsau, 01.08.2018
(location, date of issue)

ZIEHL-ABEGG SE
Dr. W. Angelis
Technical Director Air Movement Division
(name, function)

i.v. W. Angelis

(Signature)

ZIEHL-ABEGG SE
Dr. D. Kappel
Deputy Head of Electrical Systems
(name, function)

i.v. David Kappel

(Signature)

Manufacturer: ZIEHL-ABEGG SE
Heinz-Ziehl-Straße
74653 Künzelsau
Germany

The manufacturer is solely responsible for issuance of the declaration of conformity.

The products:

- **External rotor motor MK..**
 - with EC type approval certificates PTB 08 ATEX 3060, PTB 08 ATEX 3061, PTB 08 ATEX 3062 as electrical equipment for potentially explosive areas, ignition protection class "e" / "eb"
 - as electrical operating equipment for potentially explosive areas, ignition protection class "nA" / "ec"
- **Internal rotor motor**
 - with EC type approval certificate or EC declaration of conformity BG080_U58_BVS_13_ATEX_E_128_X, BG090_U58_BVS_13_ATEX_E_098_X, BG100_U58_BVS_13_ATEX_E_127_X, BG112_U58_BVS_13_ATEX_E_126_X, BG132_U58_BVS_13_ATEX_E_099_X, BG160_U58_BVS_13_ATEX_E_019_X, BG180_U58_BVS_13_ATEX_E_017_X, BG200_U58_BVS_13_ATEX_E_012_X, BG225_U58_BVS_12_ATEX_E_103_X, BG250_U58_BVS_11_ATEX_E_045_X and PTB 12 ATEX 3016 as electrical operating equipment for potentially explosive areas, ignition protection class "d" / "db", "de" / "db eb", "tb" and "tc"
 - with EC type approval certificate or EC declaration of conformity PTB 05 ATEX 3006, PTB 12 ATEX 3014 and BVS 14 ATEX E 081 as electrical operating equipment for potentially explosive areas, ignition protection class "nA" / "ec"
 - with EC type approval certificates or EC declarations of conformity Baseefa 13 ATEX 0016 X, Baseefa 13 ATEX 0079 X, Baseefa 13 ATEX 0288 X, Baseefa 14 ATEX 0208 X as electrical operating equipment for potentially explosive areas, ignition protection class "d", "db", "de", "db eb" and "tb"
 - with EC type approval certificate or EC declaration of conformity CNEX 17 ATEX 0004 X as electrical operating equipment for potentially explosive areas, ignition protection class "db" and "tb"
- **Axial fan FB.. of Group II, Device Category 2G**

with EC model test certificate ZELM 04 ATEX 0236 X, with protection type "c" for conveying explosive gas atmospheres of Group IIB for zone 1 and zone 2, with external rotor motor MK.. for explosive areas, protection type "e" / "eb".
- **Group II, 3G appliance category FB.. axial fan**

type of protection "c" / "h" for the conveyance of potentially explosive, group IIB for zone 2 gas atmospheres; type of protection "nA" / "ec" with an external rotor motor MK.. for explosion-hazardous areas
- **Group II, 2G appliance category RE.., RH.. centrifugal fans**

type of protection "c" "h" for the conveyance of potentially explosive, group IIB gas atmospheres for zones 1 and 2, with an external rotor motor MK.. with EC type approval certificates PTB 08 ATEX 3060, PTB 08 ATEX 3061, PTB 08 ATEX 3062 for explosion-hazardous areas, type of protection "e" / "eb"
- **Group II, 3G appliance category RE.., RH.. centrifugal fans**

type of protection "c" / "h" for the conveyance of potentially explosive, group IIB gas atmospheres for zone 2, with an external rotor motor MK.. for explosion-hazardous areas, type of protection "nA" / "ec".
- **Group II, 3D appliance category RE.., RH.., GR.. centrifugal fans**

type of protection "c" / "h" for the conveyance of potentially explosive, group IIB dust atmospheres for zone 22, with an EC-internal rotor motor MK.. for explosion-hazardous areas, type of protection "tc"
- **Group II, 2G appliance category ER.. centrifugal fans**

type of protection "c" / "h" for the conveyance of potentially explosive, group IIB gas atmospheres for zone 1 and zone 2, with an internal rotor motor for explosion-hazardous areas, type of protection "d" / "db"

- **Group II, 3G equipment category GR.., RG.. centrifugal fans**
ignition protection class “c” / “h” for conveyance of explosive, group IIB gas atmospheres for zone 2, with internal rotor motor for potentially explosive areas, ignition protection class “nA” / “ec”
- **Group II, 3D appliance category GR.., RG.. centrifugal fans**
type of protection "c" / "h" for the conveyance of potentially explosive, group IIIB dust atmospheres for zone 22, with an internal rotor motor for explosion-hazardous areas, type of protection "tc"

These products are developed, designed and manufactured according to the following directives:

- EMC Directive 2014/30/EU
- ATEX Directive 2014/34/EU

The following harmonised standards have been used:

EN 61000-6-3:2007	EN 60079-31:2014
EN 61000-6-2:2005	EN 1127-1:2011
EN 60079-0:2012+A11:2013	EN 80079-36:2017
EN 60079-7:2015	EN 80079-37:2016
EN 60079-15:2010	

- **The following standard is in use for FB axial fans**

EN14986:2017 Design of fans working in potentially explosive atmospheres
Note: The manufacturer of the plant is responsible for the complete compliance with the standard EN14986:2017 as well as for the compliance with the combinations of material and the minimum gap.
Compliance with the EN14986:2017 standard relates only to the installed protective grille and the inlet nozzle, if these are included in the scope of supply.

- **The following standard is in use for RE.., RH.., ER.., GR.. and RG.. centrifugal fans:**

EN14986:2017 Design of fans working in potentially explosive atmospheres
Note: The manufacturer of the plant is responsible for the complete compliance with the standard EN14986:2017 as well as for the compliance with the combinations of material and the minimum gap.
Also applicable to ER:
Compliance with the EN14986:2017 standard relates only to the installed protective grille and the inlet nozzle, if these are included in the scope of supply.

Name , address and identification number of the notified location:

- **For external rotor motors MK :**
Physikalisch-Technische Bundesanstalt (PTB)
Bundesallee 100 , D - 38116 Braunschweig , identification number 0102
- **For axial fans FB :**
ZELM Ex E.K. - Testing and Certification Body
Siekgraben 56 , D - 38124 Braunschweig , identification number 0820
- **For centrifugal fans RE .. , RH .. , ER .. :**
Federal Institute for Materials Research and Testing (BAM)
Unter den Eichen 87 , D - 12205 Berlin , identification number 0589

Compliance with the EMC Directive 2014/30 / EU refers only to those products when they are connected by mounting / operating instructions . If these products are integrated into a system or supplemented with other components (eg. sensing controls) and operated , the manufacturer or operator is responsible of the overall system for compliance with the EMC Directive 2014/30 / EU .

Künzelsau, 01.08.2018
(location, date of issue)

ZIEHL-ABEGG SE
Dr. W. Angelis
Technical Director Air Movement Division
(name, function)

i.v. W. Angelis

(Signature)

ZIEHL-ABEGG SE
Dr. D. Kappel
Deputy Head of Electrical Systems
(name, function)

i.v. David Kappel

(Signature)

A.2 Nicotra Gebhardt RLM... fan

Name	Data
Designation	Fans
Type	RLM...
Number	
Type of manual	Operating manual
Manufacturer	Nicotra Gebhardt

Betriebsanleitung

ATEX - Ventilatormodule ohne Gehäuse

(Original)

DE

Operating Instructions

ATEX - Centrifugal fans without scroll

(Translation of the original)

EN



II 2G Ex h IIB(+H2) T4 Gb

BA-CFD-RLM-ATEX 4.0 – 05/2019

		<p>RLM E6 RLM E3 RLM G6</p>
		<p>RLM 55 RLM 56</p>

Inhaltsverzeichnis

Inhaltsverzeichnis	DE-2
1. Revisionsindex	DE-2
2. Zu dieser Betriebsanleitung	DE-3
3. Bestimmungsgemäße Verwendung	DE-5
4. Sicherheit	DE-7
5. Produktbeschreibung	DE-10
6. Transport und Lagerung.....	DE-11
7. Montage.....	DE-12
8. Elektrischer Anschluss	DE-15
9. Inbetriebnahme	DE-17
10. Instandhaltung.....	DE-18
11. Störungen.....	DE-20
12. Service, Ersatzteile und Zubehör	DE-21
13. Anhang	DE-21
EU-Konformitätserklärung zur ATEX-Richtlinie 2014/34/EU.....	DE-22
EG-Einbauerklärung.....	DE-23

English

EN-2...EN-23

weitere Sprachen auf Anfrage

1. Revisionsindex

Table 1-1: Revisionsindex

Revision	Datum
BA-CFD-RLM-ATEX 3.1 – 08/2011	08/2011
BA-CFD-RLM-ATEX 3.2 – 03/2012	03/2012
BA-CFD-RLM-ATEX 3.3 – 01/2013	01/2013
BA-CFD-RLM-ATEX 3.4 – 03/2013	03/2013
BA-CFD-RLM-ATEX 3.5 – 06/2014	06/2014
BA-CFD-RLM-ATEX 3.6 – 12/2014	12/2014
BA-CFD-RLM-ATEX 3.7 – 03/2015	03/2015
BA-CFD-RLM-ATEX 3.8 – 12/2015	12/2015
BA-CFD-RLM-ATEX 3.9 – 04/2016	04/2016
BA-CFD-RLM-ATEX 4.0 – 05/2019	05/2019

2. Zu dieser Betriebsanleitung



Diese Betriebsanleitung ist Teil des Ventilators.

Für Schäden und Folgeschäden, die durch Nichtbeachtung der Betriebsanleitung entstehen, übernimmt Nicotra Gebhardt keinerlei Haftung oder Gewährleistung.

- ▶ Betriebsanleitung vor Gebrauch aufmerksam lesen.
- ▶ Betriebsanleitung während der Lebensdauer des Ventilators aufbewahren.
- ▶ Betriebsanleitung dem Personal jederzeit zugänglich machen.
- ▶ Betriebsanleitung an jeden nachfolgenden Besitzer oder Benutzer des Ventilators weitergeben.
- ▶ Jede vom Hersteller erhaltene Ergänzung in die Betriebsanleitung einfügen.

2.1. Gültigkeit

Diese Betriebsanleitung ist nur gültig für die auf der Titelseite angegebenen Ventilatoren.

2.2. Zielgruppe

Zielgruppe dieser Betriebsanleitung sind Betreiber und ausgebildetes Fachpersonal, das mit Montage, Inbetriebnahme, Bedienung, Instandhaltung und Außerbetriebnahme vertraut ist.

2.2. Zielgruppe

2.3. Mitgeltende Dokumente

- ▶ **Zusätzlich zu der dem Ventilator beiliegenden Betriebsanleitung, den am Ventilator angebrachten Typen-, Warn- und Hinweisschildern, folgende Dokumente beachten:**
 - DIN VDE 0100-100
 - DIN EN 60204-1
 - DIN EN ISO 13857
 - DIN EN ISO 12100
 - DIN EN ISO 13732-1
 - DIN EN ISO 80079-36;-37
 - DIN EN 1127-1
 - DIN EN 60079-0
 - DIN EN 14986
 - Technischer Katalog
 - EU-Richtlinie 2014/34/EU

2.4. Symbole und Kennzeichnungen

2.4.1. Aufbau von Warnhinweisen





Signalwort

Art, Quelle und Folgen der Gefahr!

- ▶ Maßnahme zur Vermeidung der Gefahr

2.4.2. Gefahrenstufen in Warnhinweisen

Tabelle 2-1: Gefahrenstufen in Warnhinweisen

Symbol / Gefahrenstufe	Eintretens-Wahrscheinlichkeit	Folgen bei Nichtbeachtung
 <p>GEFAHR!</p>	Unmittelbar drohende Gefahr	Tod, schwere Körperverletzung
 <p>WARNUNG!</p>	Mögliche drohende Gefahr	Tod, schwere Körperverletzung
 <p>VORSICHT!</p>	Mögliche drohende Gefahr	Leichte Körperverletzung
<p>VORSICHT</p>	Mögliche drohende Gefahr	Sachschaden

2.4.3. Hinweise

Hinweis Hinweis zum leichteren bzw. sicheren Arbeiten.

- ▶ Maßnahme zum leichteren bzw. sicheren Arbeiten.

2.4.4. Sonstige Symbole und Kennzeichnungen

Tabelle 2-2: Sonstige Symbole und Kennzeichnungen

Symbol	Bedeutung
☑	Voraussetzung zu einer Handlung
▶	Handlung mit einem Schritt
1. 2. 3.	Handlung mit mehreren Schritten
•	Aufzählung (1. Ebene)
-	Aufzählung (2. Ebene)
Hervorhebung (fett)	Hervorhebung

3. Bestimmungsgemäße Verwendung

3.1. Betriebsdaten / Grenzdaten



Verletzungsgefahr!
 ► Technische Daten und zulässige Grenzwerte einhalten.

Die Technischen Daten sind dem Typenschild, dem technischen Datenblatt und dem technischen Katalog zu entnehmen!

Hinweis ATEX Kategorie II 2G Ex h IIB T4 Gb
 Ventilatoren dieser Kategorie sind zur Verwendung in Bereichen bestimmt, in denen damit zu rechnen ist, dass eine explosionsfähige Atmosphäre aus einem Gemisch von Luft und Gasen, Dämpfen oder Nebeln gelegentlich auftritt. Die gerätebezogenen Explosionsschutzmaßnahmen dieser Kategorie müssen selbst bei häufigen Gerätestörungen oder Fehlerzuständen, die üblicherweise zu berücksichtigen sind (vorhersehbare Störungen), das erforderliche Maß an Sicherheit bieten.
 Für den Betrieb der Ventilatoren in explosionsgefährdeten Bereichen sind die einschlägigen Bestimmungen und örtlichen Vorschriften und entsprechenden Richtlinien (ATEX 2014/34/EU) für den Hersteller und Betreiber zu beachten.



Die Aufstellung bei RLM E6/G6/55/56 ist nur mit horizontaler Achse, bei RLM E3 nur mit vertikaler Achse gestattet.

Tabelle 3-1:
Grenzdaten

Zulässige Fördermediumstemperaturen ATEX		
Baureihe	zul. Temperatur des Fördermediums	max. Umgebungstemperatur am Antriebsmotor
RLM 55/56/G6/E6/E3	-20°C ... +40°C (60°C)	+ 40°C (60°C)

Bei Motoreignung für eine Kühlmitteltemperatur bis +60°C kann der Temperaturbereich in Sonderfällen auf diesen Wert ausgeweitet werden! (Unter Berücksichtigung einer Leistungsreduzierung nach Herstellerangaben)

- 3.1.1 Als nicht bestimmungsgemäße Verwendung gilt z.B. die Förderung:
 - von Medien mit unerlaubten hohen oder niedrigen Temperaturen
 - von aggressiven Medien
 - von stark staubhaltigen Medien
- 3.1.2 Die Folgen von nicht bestimmungsgemäßigem Einsatz sind:
 - Lagerschäden
 - Korrosionsschäden
 - Unwucht
 - Vibration
 - Deformation
 - Abrieb

VORSICHT Unerlaubte Betriebszustände

- Kein Betrieb über der angegebenen Drehzahl (Typenschild, technische Daten)
- Kein Betrieb in Drehzahlbereichen erhöhter Schwingungen (Resonanz)
- Kein Betrieb in Drehzahlbereichen außerhalb des zulässigen Kennfeldbereiches (Strömungsstabilität)
- Kein Betrieb bei Verschmutzung des Ventilators
- Kein Betrieb wenn Ventilator nicht spannungs- und kräftefrei montiert ist



Als Gefahr drohen:

Personenschäden- und Sachschäden durch Wellenbrüche, Laufradbrüche, Dauerbrüche, oder Explosionen durch Funkenbildung

3.2. Explosionsschutz-Kennzeichnung

Die Kennzeichnung von Ventilatoren in explosionsgeschützter Ausführung erfolgt durch Angabe der Gerätegruppe, Kategorie, Zündschutzart und Temperaturklasse auf dem Typenschild sowie durch ein CE-Ex-Zeichen, durch das die Konformität des Geräts mit der europäischen ATEX-Richtlinie 2014/34/EU bestätigt wird.

Die Einbauerklärung und Konformitätserklärung zur ATEX-Richtlinie 2014/34/EU befinden sich im Anhang dieser Betriebsanleitung.

Richtlinienteil | Normenteil

CE Ex II 2 G Ex h IIB(+H2) T4 Gb

| | | | | | | | | |
 A B 1 2 3 4 5 6 7 8

Bild 3-1:
Explosionsschutz-
Kennzeichnung
(Beispiel)

A	CE-Kennzeichnung	
B	Ex-Geräte Kennzeichnung (lt. ATEX-Richtlinie)	
1	Gerätegruppe II	Nichtelektrische Geräte außerhalb von Bergbau- und Untertagebau-Einsatz
2	Geräteklasse 2	(innen und außen) einsetzbar in Zone 1+2; nur gelegentliche Ex-Atmosphäre in der Umgebung
3	Fördermedium G	Gasförmige Fördermedien
4	Ex-Symbol	Lt. EN ISO-Norm 80079-36
5	Ersatz-Zündschutzart h	Explosionsschutz durch konstruktive Sicherheit
6	Explosionsgruppe IIB (+H2)*	Art der Gasatmosphäre
7	Temperaturklasse T4	max. Oberflächentemperatur am Gerät +135°C
8	Geräteschutzniveau Gb	Bei Gas in Zone 1 - Gb (in Zone2 – Gc)

* (+H2) gilt nur für RLM E6, RLM G6 und RLM E3:

Für wasserstoffhaltige Gasgemische mit max. 4 % Wasserstoff (UEG); Voraussetzung ist eine Materialpaarung zwischen den rotierenden Teilen in Stahl (Edelstahl) – Kupfer und die Verwendung eines Ex de IIC T4 Motors.

4. Sicherheit

4.1. Produktsicherheit

Die Ventilatoren bieten ein hohes Maß an Betriebssicherheit und einen hohen Qualitätsstandard, der durch ein zertifiziertes Qualitätsmanagement-System (EN ISO 9001) gewährleistet wird.

Alle Ventilatoren werden vor Verlassen des Werkes einer Kontrolle unterzogen und mit einem Prüfsiegel versehen.

Dennoch können beim Betrieb der Ventilatoren Gefahren für Leib und Leben des Benutzers oder Dritter bzw. Beeinträchtigungen des Ventilators und anderer Sachwerte entstehen.

- Ventilator nur in technisch einwandfreiem Zustand sowie bestimmungsgemäß, sicherheits- und gefahrenbewusst unter Beachtung der Betriebsanleitung betreiben.
- Störungen, die die Sicherheit beeinträchtigen können, umgehend beseitigen lassen.



Explosionsfähige Gasgemische können in Verbindung mit heißen und bewegten Teilen schwere oder tödliche Verletzungen verursachen.

**Explosionsgefahr durch erhöhte Umgebungstemperatur!
Umgebungstemperatur beobachten.
Für ausreichende Kühlluftzufuhr sorgen**

4.2. Sicherheitsvorschriften

Ventilator nur in Übereinstimmung mit folgenden Vorschriften in Betrieb nehmen, betreiben und instand halten:

- Betriebsanleitung
- Warn- und Hinweisschilder am Ventilator
- Alle anderen zur Anlage gehörenden Betriebs- und Montageanleitungen
- Anlagenspezifische Bestimmungen und Erfordernisse
- Gültige nationale und regionale Vorschriften, insbesondere zu Explosionsschutz, Sicherheit, Unfallverhütung

4.3. Schutzeinrichtungen

1. Rotierende Teile (Wellen, Laufrad usw.) durch geeignete Schutzeinrichtungen gegen Berührung sichern.
2. Schutzvorrichtungen so auslegen, dass das Ansaugen oder Hineinfallen von Gegenständen verhindert wird.
3. Schutzvorrichtungen, die bei der Montage demontiert wurden, unmittelbar nach der Montage (und vor dem elektrischen Anschluss) wieder anbringen.



GEFAHR!

Die Ventilatoren werden mit saugseitigem Berührungsschutz geliefert. Besteht durch die Art des Einbaus die Gefahr einer Berührung des Laufrades, so sind bauseitig Schutzgitter entsprechend DIN EN ISO 13857 anzubringen. Erst dann darf der Ventilator in Betrieb gesetzt werden!



GEFAHR!

ATEX Ventilatoren der Kategorie 2G und 3G müssen gegen das Eindringen von Gegenständen geschützt werden (min. IP20 nach DIN EN 60529).

Vom Anlagenbetreiber müssen geeignete Maßnahmen ergriffen werden!



VORSICHT!

Die Eignung der Schutzeinrichtungen und deren Befestigungen am Ventilator sind im Zusammenhang mit dem gesamten Sicherheitskonzept der Anlage zu bewerten.

4.4. Qualifikation des Personals

1. Sicherstellen, dass die Montage und alle Arbeiten am Ventilator nur von Fachmonteuren unter Beachtung dieser Betriebsanleitung sowie den gültigen Vorschriften ausgeführt werden.
2. Elektroanschluss nur durch ausgebildete Elektro-Fachkraft ausführen lassen.

4.5. Schutzausrüstung



VORSICHT!

Sicherstellen, dass das Personal je nach Einsatz und Umgebungsbedingung geeignete Schutzausrüstung trägt.
Die Schutzkleidung ist in den folgenden Abschnitten beschrieben!

4.6. Besondere Gefahren

4.6.1. Geräuschemission



Die zu erwartende Schallemission für den bestimmungsgemäßen Betrieb des Ventilators ist in den technischen Katalogen dokumentiert und entsprechend zu berücksichtigen.

- ▶ **Gehörschutz tragen bei Arbeiten in der Nähe - oder am laufenden Ventilator!**

4.6.2. Schwere Lasten

Aufgrund des hohen Gewichts des Ventilators und seiner Komponenten ergeben sich bei Transport und Montage (Demontage) folgende Gefahren:

- Klemm-, Quetsch- und Schneidgefahren durch Bewegungen oder Kippen
- Gefahren durch Herabfallen von Komponenten



- ▶ **Nicht unter schwebenden Lasten aufhalten oder arbeiten.**
- ▶ **Schutzhelm, Sicherheitsschuhe und Handschuhe tragen.**

4.6.3. Rotierende Wellen und Laufräder

Auf rotierende Wellen und Laufräder fallende Gegenstände können wegfliegen und schwere Verletzungen verursachen. Kleidungsstücke oder Haare können sich an rotierenden Wellen und in Laufrädern verfangen.



- ▶ **Schutzvorrichtungen während des Betriebs nicht entfernen.**
- ▶ **eng anliegende Kleidung tragen, bei Arbeiten in der Nähe rotierender Wellen und Laufräder mit hoher Strömungsenergie**
- ▶ **Schutzbrille tragen**

4.6.4. Heiße Oberflächen

Im Betrieb besteht Verbrennungs- und Verbrühungsgefahr aufgrund heißer Oberflächen.



- ▶ **Motor während des Betriebs nicht berühren.**
- ▶ **Bei Stillstand des Ventilators warten, bis sich der Motor abgekühlt hat.**
- ▶ **Schutzhandschuhe tragen**

4.7. Bauliche Veränderungen, Ersatzteile

Hinweis Eigenmächtige bauliche Veränderungen am Ventilator sind ohne Zustimmung von Nicotra Gebhardt nicht zulässig. Für daraus entstandene Schäden übernimmt Nicotra Gebhardt keine Haftung. Es dürfen nur Original-Ersatzteile von Nicotra Gebhardt verwendet werden.

VORSICHT Im Ex-Bereich dürfen nur die Nicotra Gebhardt GmbH selbst, eine durch sie autorisierte Servicestelle oder durch sie ermächtigtes und ausgebildetes Personal den Ventilator ändern oder umrüsten.

4.8. Installation und Instandhaltung

Vor Arbeiten am Ventilator folgende Maßnahmen durchführen:

1. Sicherstellen, dass keine explosionsfähige Atmosphäre vorhanden ist.
2. Anlage abschalten und gegen unbeabsichtigtes Wiedereinschalten sichern.
3. Schild mit folgendem Text anbringen:
Nicht einschalten! An der Anlage wird gearbeitet.

4.9. Schilder auf dem Ventilator

Typenschild und Drehrichtungspfeil sind je nach Baureihe gut sichtbar am Ventilator angebracht.

4.9.1. Typenschild

Bild 4-1:
Typenschild-Muster

Nicotra Gebhardt		D-74638 Waldenburg	CE
Tel.: +49 (0)7942 101 384		Fax: -385	
E-Mail: service@nicotra-gebhardt.com			
RLM 56-3540-4Y-11-2G			
GERÄTE-Nr.	128-260549-220255/2	HERSTELLJAHR 2010	
VENTILATOR		MOTOR	
Dichte	= 1.2 kg/m ³	UN	= 400 V (D/Y)
T max	= 40 °C	FN	= 50 Hz
n max	= 1810 1/min	F max	= 64 Hz
Nur Muster!		I N	= 3.3 / 1.88 A
		nN	= 1395 1/min
		P N	= 0.75 kW
		Schutzart	= P55
		Wärmeklasse	= F
		Stromart	= 3~
CE Ex II 2G Ex h IIB T4 Gb (innen/außen)			

4.9.2 Drehrichtungspfeil

Bild 4-2:
Drehrichtungspfeil

4.9.3 Klemmbrett-Schaltbild

Bild 4-3:
Muster-Schaltbild

Das Anschluss Schaltbild befindet sich im Anschlussklemmenkasten des Normmotors.

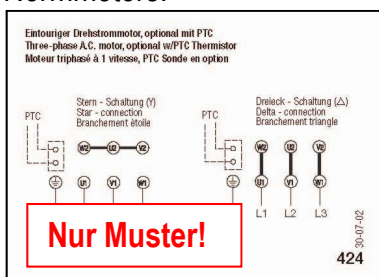

5. Produktbeschreibung

5.1. Ventilatoren RLM



Ventilatoren RLM, optimiert zur Verwendung ohne Spiralgehäuse, mit Direktantrieb durch Anbaumotoren. Das Radiallaufrad mit rückwärtsgekrümmten Schaufeln ist direkt auf der Welle des Anbaumotors befestigt. Die Ventilatoreinheit mit Motorlaufrad, Einströmdüse, Motorbock und Grundrahmen werden werksseitig montiert und justiert! Die Ventilatoren sind standardmäßig mit einer Volumenstrom-Messeinrichtung und einem Ansaugschutzgitter ausgestattet. Die Ventilatoren RLM erfüllen die Anforderungen der ATEX-Richtlinie 2014/34/EU durch konstruktive Sicherheit und sichere Bauweise entsprechend DIN EN ISO 80079-36 und -37 und DIN EN 14986. Die Einordnung erfolgt in Gerätegruppe II, Kategorie 2G, Explosionsgruppe IIB(+H₂), Temperaturklasse T4(T₃) und Geräteschutzniveau EPL Gb.

Materialpaarung:

- **Laufrad** aus Stahlblech, beschichtet bzw. Edelstahl
- **Einströmdüse** aus Kupfer.

**Hinweis ATEX Ventilatoren dürfen nicht verändert werden!
Bei Veränderungen erlischt die ATEX – Konformität!**

5.2. Ventilatoren RLM

5.2.1 Ventilatoren RLM mit Direktantrieb

RLM 55-1112/-1214

RLM 56-2528/-1011 / RLM E3 –2528/-6371

RLM G6-2225 / RLM E6-2528/-1011

Bild 5-1:
Ausführungen

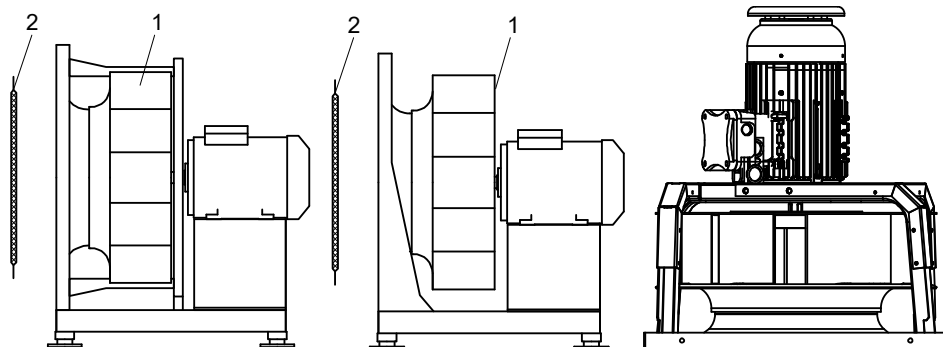

1. Ventilator
2. Schutzgitter für die Eintrittsseite (im Lieferumfang enthalten)
 - Berührungsschutz nach DIN EN ISO 13857
 - Schutz gegen das Eindringen von Gegenständen nach DIN EN 60529

6. Transport und Lagerung

6.1. Verpackung

Ventilatoren werden abhängig von Baugröße und Gewicht in stabilen Kartonagen oder Holzverschlügen verpackt bzw. auf stabile Paletten geschraubt. Hinweise auf das Entfernen von Transportsicherungen sind ggf. beigelegt.

6.2. Symbole auf der Verpackung

Auf den Kartonagen sind folgende Symbole angebracht:

Tabelle 6-1: Symbole auf der Verpackung

Symbol			
Bedeutung	Zerbrechliches Gut	Vor Nässe schützen	Oben

6.3. Ventilator transportieren



Verletzungsgefahr durch herabfallende Komponenten!

Nur geprüfte und für den jeweiligen Ventilator geeignete Lastaufnahmemittel verwenden!

Ventilator so lange wie möglich mit der Originalverpackung transportieren!
Ladung sichern!

- **Nicht unter schwebenden Lasten aufhalten!**

1. Transportmittel entsprechend dem Ventilatorgewicht, der Bauform oder der Aufhängemöglichkeit auswählen
(Gewichte siehe technischer Katalog)
2. Ventilator an Grundrahmen, Grund- oder Tragplatte aufnehmen.
3. Bei Transportgurten immer Vierpunktaufhängung vorsehen
(2 Gurtschlaufen). Die Gurtschlaufen dürfen keine verformende Kraft auf Ventilator oder Verpackung ausüben, gegebenenfalls Distanzstücke verwenden!
4. Ladung z. B. durch Transportgurte oder Rutschsicherungen sichern.
Ventilator sorgfältig transportieren und Schäden z. B. durch Stöße und hartes, verkantetes Aufsetzen vermeiden.

VORSICHT Keine Befestigungspunkte am Ventilator sind!

- Motortransportösen
- Laufrad
- Einströmdüse

6.4. Ventilator lagern

VORSICHT Korrosionsgefahr!

- ▶ Ventilator in Verpackung einlagern bzw. diese in Abhängigkeit von den äußeren Einflüssen ergänzen.
- ▶ Ventilator nur in einem gut durchlüfteten Raum unter normalen Temperaturverhältnissen und in einer nicht korrosiven Atmosphäre lagern.
- ▶ Ventilator bei Luftfeuchtigkeit unter 70 % (nicht kondensierend) lagern.
- ▶ Max. zulässige Temperatur von -20°C bis $+40^{\circ}\text{C}$ einhalten.

7. Montage

7.1. Sicherheitshinweise zur Montage

- ▶ Sicherheitshinweise und Schutzmaßnahmen in Kapitel 4 sowie die gültigen gesetzlichen Vorschriften beachten.

VORSICHT Das von Nicotra Gebhardt gelieferte ATEX-Ventilatorsystem darf in keiner Weise bauseitig verändert werden.
Der Betrieb ist nur im Originalzustand innerhalb der technisch festgelegten Grenzen zulässig!
(Katalog- und Typenschilddaten beachten).

7.1.1. Einbauhinweise

Um eine ausreichende Motorkühlung zu gewährleisten, ist ein Mindestabstand (L1) vom Ende des Motors bis zur Gehäusewand einzuhalten. Angaben zu L1 sind der beiliegenden Motor-Betriebsanleitung zu entnehmen.

Bild 7-1: Freiraum

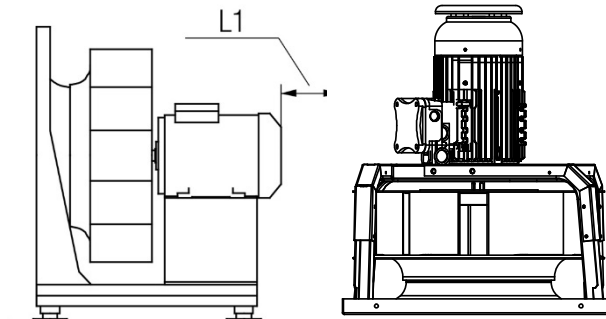

RLM E3: nur vertikaler Einbau, mit Luftrichtung von unten nach oben, zulässig. Mindestabstand durch Motorschutzdach vorgegeben.

7.2. Montage vorbereiten

- Der Aufstellungsort ist in Art, Beschaffenheit, Umgebungstemperatur und Umgebungsmedium für den jeweiligen Ventilator geeignet.
- Die Unterkonstruktion ist eben und ausreichend tragfähig.
 1. Ventilator vorsichtig auspacken.
 2. Transportsicherungen ggf. demontieren.
 3. Verpackungsmaterial vollständig entfernen und fachgerecht entsorgen.
 4. Spaltmaß gemäß 7.4 prüfen.

7.3. Montage durchführen

1. Ventilator bzw. Grundrahmen spannungs- und kräftefrei auf der Unterkonstruktion befestigen bzw.-
 2. lose beigefügte Schwingungsdämpfer gleichmäßig um den Ventilator-schwerpunkt verteilt ausrichten und befestigen, dabei auf gleichmäßige Einfederung achten.
 3. Erdung des Ventilators ordnungsgemäß herstellen. Die Schwingungsdämpfer selbst gewährleisten keinen elektrischen Durchgang.
- Von Anlagenteilen werden keine Kräfte oder Schwingungen auf den Ventilator übertragen (flexible Anschlussstutzen)!
 - Die flexiblen saug- und /oder druckseitigen ATEX-Anschlussstutzen sind schwingfähig und ohne Versatz montiert und anlagenseitig geerdet.
 - Die Schwingungsdämpfer schwingen frei und sind gleichmäßig eingefedert!
 - Das Laufrad dreht frei und streift nicht an der Einströmdüse (Mindestspalte beachten, s. 7.4)!
 - Die Abstände vom Laufrad zu den bauseitigen Anlagenteilen sind geprüft und entsprechen den Explosionsschutzanforderungen.
 - Ventilator auf Standsicherheit geprüft (kein Kippen möglich).

7.4 Spaltmaß am Ventilator prüfen

- ▶ Spaltweite zwischen Laufrad und Einströmdüse, sowie zwischen Laufradkante und Messnippel der Volumenstrom - Messeinrichtung prüfen und mit den Tabellenwerten abgleichen!

Bild 7-2: Spaltmaße



Bild 7-3: Messpunkte

Tabelle 7-1: Spaltmaße

RLM	Spaltmaß „s“	RLM	Spaltmaß „s“
2225	2,0	5663	4,3
2528	2,0	6371	4,8
2831	2,2	7180	5,4
3135	2,4	8090	6,0
3540	2,7	9010	6,7
4045	3,0	1011	7,5
4550	3,4	1112	8,5
5056	3,8	1214	9,5

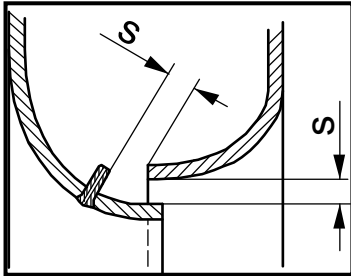
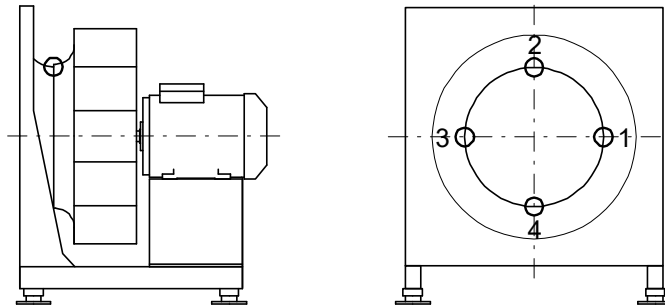

1. Spalt messen, Sicherstellen, dass das Spaltmaß in keiner Phase der Drehbewegung (von Hand drehen) unterschritten wird.
2. Messung an vier um 90° versetzten Punkten am Umfang durchführen. Lehre liegt am Außendurchmesser der Einströmdüse an.

7.5 Volumenstrom-Messeinrichtung



Bild 7-4: Volumenstrom-Messeinrichtung

Bild 7-5: Einbauventilator

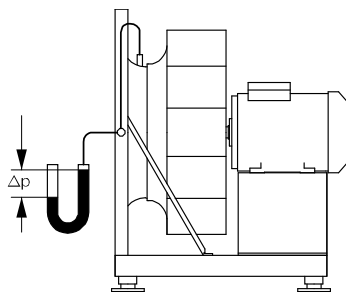
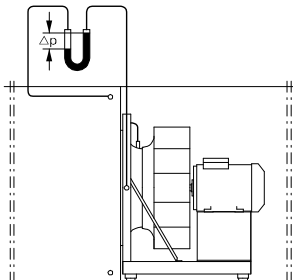

Standardmäßig sind die Ventilatoren mit einer Volumenstrom-Messvorrichtung ausgestattet. Dadurch ist eine einfache Volumenstrombestimmung und -überwachung des Ventilators im Einbauzustand möglich.

- Messstutzen in der Einströmdüse
- Schlauchleitung zum Anschlussstück an der Trageinheit
- Anschlussstück (Aussendurchmesser 6mm) für die Druckmessung

$$q_v = K \times \sqrt{\frac{2}{\rho} \times \Delta p_{Dü}}$$

- q_v Volumenstrom [m³/h]
- K Kalibrierfaktor [m²s/h]
- ρ Gasdichte [kg/m³]
- Δp_{Dü} Differenzdruck Düse [Pa]

Bei Ventilatoren, die in eine Kammer eingebaut sind, ist die Druckdifferenz zwischen statischem Druck in der saugseitigen Kammer und Druck an der Einströmdüse zu messen. Es ist darauf zu achten, dass der zu messende statische Druck vor der Einströmdüse nicht durch dynamische Druckanteile verfälscht wird. Häufig empfiehlt sich die Anordnung einer Ringleitung an der Wand zur Druckseite (siehe Skizze).

Wird der Differenzdruck über einen Drucksensor geführt, kann das Signal auch für Regelzwecke verwendet werden.

Zur Berechnung des Volumenstroms wird ein Kalibrierfaktor „K“ für den jeweiligen Ventilator benötigt, der durch eine Vergleichsmessung auf einem Normprüfstand bei ungestörter Zuströmung ermittelt wird.

K-Faktor Abweichung
Standard Kalibrierfaktor
K10 < 10%

RLM E6- E3-G6	Kalibrierfaktor K10	RLM 56- 55-	Kalibrierfaktor K10
2225	73 m ² /s/h	2528	73 m ² /s/h
2528	79 m ² /s/h	2831	90 m ² /s/h
2831	94 m ² /s/h	3135	105 m ² /s/h
3135	106 m ² /s/h	3540	120 m ² /s/h
3540	128 m ² /s/h	4045	150 m ² /s/h
4045	155 m ² /s/h	4550	190 m ² /s/h
4550	190 m ² /s/h	5056	240 m ² /s/h
5056	242 m ² /s/h	5663	300 m ² /s/h
5663	310 m ² /s/h	6371	385 m ² /s/h
6371	385 m ² /s/h	7180	485 m ² /s/h
7180	490 m ² /s/h	8090	620 m ² /s/h
8090	628 m ² /s/h	9010	790 m ² /s/h
9010	794 m ² /s/h	1011	1000 m ² /s/h
1011	1017 m ² /s/h	1112	1260 m ² /s/h
		1214	1540 m ² /s/h

7.6 Schutzvorrichtungen montieren

1. Frei zugängliche Eintrittsöffnungen mit Schutzvorrichtungen (DIN EN ISO 13857) sichern.
2. Schutzvorrichtungen so auslegen, dass das Ansaugen oder Hineinfallen von Gegenständen verhindert wird (DIN EN 60529).

8. Elektrischer Anschluss

8.1. Sicherheitshinweise zum elektrischen Anschluss



Achtung, Gefahr durch Stromschlag!

- ▶ Sicherheitshinweise und Schutzmaßnahmen in Kapitel 4 sowie die gültigen gesetzlichen Vorschriften beachten.
- ▶ EN 60204-1, DIN VDE 0100-100; DIN EN 60079-0, VDE 0170-1, DIN EN 60079-14, VDE 0165-1

Alle Ventilatoren werden anschlussfertig geliefert. Der Motor-Klemmenkasten ist leicht zugänglich. Das Anschlussschaltbild befindet sich im Klemmkastendeckel. Schutzsysteme sind bauseits vorzusehen und gehören nicht zum Lieferumfang von Nicotra Gebhardt.

Bei Varianten mit max. Betriebsfrequenz < 50 Hz ist kein Netzbetrieb zulässig!

Hinweis Die Ventilatoren sind standardmäßig für den Betrieb mit Frequenzumrichter geeignet. Beim Einsatz von Frequenzumrichtern bzw. Regelgeräten mit elektronischen Komponenten, sind die Empfehlungen des Geräteherstellers zur Vermeidung von elektromagnetischen Störungen (EMV) zu beachten (Erdung, Kabellängen, Kabelabschirmungen, etc.).

VORSICHT **Sachschaden durch Revisionsschalter, elektronisches Steuergerät und Frequenzumrichter!**

- ▶ Kein elektronisches Steuergerät und keinen Frequenzumrichter im Ex-Bereich verwenden.
- ▶ Revisionsschalter – ausgenommen Ex-Revisionsschalter – außerhalb des Ex-Bereichs montieren.

Hinweis Die Normmotoren sind in Schutzart “druckfeste Kapselung Ex de II”, Temperaturklasse T4 für Umgebungstemperaturen -20°C bis +40°C (60°C) nach Richtlinie 2014/34/EU (ATEX) bzw. IEC/EN 60079-0, IEC/EN 60079-1 ausgeführt.

- ▶ Stromart, Spannung und Frequenz des Netzanschlusses auf Übereinstimmung zum Ventilator- bzw. Motortypenschild geprüft
- ▶ Bei Motoren mit Nennleistung >4 kW Stern-Dreieck-Anlauf oder Sanftanlauf berücksichtigen.
- ▶ Die Leistungsbegrenzung des Energieversorgungsunternehmens sind beachtet!
- ▶ Ggf. Revisionsschalter vorhanden (außerhalb des Ex-Bereiches)
- ▶ Die Bauteile des Ventilators sind untereinander leitend verbunden, die Erdung ist sichergestellt!
- ▶ **Der Ventilator ist gegen unerwarteten Anlauf geschützt!**
- ▶ **Kapitel 4. „Sicherheit“ wird beachtet!**

8.2. Motor anschließen



Bild 8-1: Anschluss RLM

1. Ggf. Revisionsschalter anbringen.
2. Anschlusskabel zum Ventilator bzw. Revisionsschalter führen.
3. Ventilator nach beigefügtem Anschlussschema anschließen.
4. Sicherstellen, dass alle elektrischen Schutzeinrichtungen angebracht und angeschlossen sind.

1 = Klemmenkasten

8.3. Motorschutz

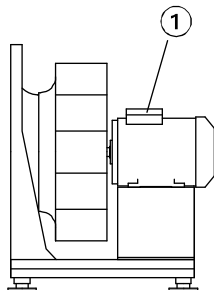
Motoren entsprechend EN 60204-1 gegen Überlast schützen.

- Regelbare, druckfest gekapselte Motoren mit geprüften Kaltleitern, sind bei EX-Anwendung mit einem ATEX-geprüften Auslösegerät zu betreiben, das den Ventilator bei einer Oberflächentemperatur von 125°C abschaltet!
- Es sind nur Motoren zulässig, die der jeweiligen ATEX – Kategorie des Ventilators entsprechen
- Motorschutzschalter auf den Motornennstrom (siehe Typenschild) einstellen. Ein höherer Einstellwert ist nicht zulässig!
- die auf dem Motortypenschild angegebene te-Zeit für Überlast-Schutzeinrichtungen beachten!

VORSICHT Schmelzsicherungen und Sicherungsautomaten aber auch einfache Bimetallschutzschalter bieten keinen ausreichenden Motorvollschutz. Bei Schäden durch unzureichenden Motorvollschutz entfällt die Herstellergarantie!

Hinweis Beachten Sie in allen Fällen die vorgegebenen Leistungsbegrenzungen vom zuständigen Energieversorgungsunternehmen.

Sollte anlagenbedingt ein Direktanlauf erforderlich sein, so ist auch die konstruktive Eignung des Ventilators von Nicotra Gebhardt zu bestätigen. Bei Ventilatoren mit einem hohen Massenträgheitsmoment des Laufrades kann es zu Hochlaufzeiten von über 6 Sekunden kommen. In diesem Fall Motorschutzschalter oder Bimetall-Relais für Schweranlauf vorsehen.

8.4. Probelauf durchführen



Verletzungsgefahr durch rotierendes Laufrad!

- ▶ Bei frei zugänglichem Ventilator nie in das Laufrad greifen.

1. Ventilator gegen unbeabsichtigtes Einschalten sichern.
2. Alle Fremdkörper (Werkzeuge, Kleinteile, Bauschutt etc.) aus dem Kanalsystem und dem Ventilator entfernen.
3. Alle Revisionsöffnungen schließen.
4. Ventilator einschalten und die Drehrichtung des Laufrades durch Vergleich mit dem Drehrichtungspfeil am Ventilator prüfen.
5. Bei falscher Drehrichtung den Motor unter Beachtung der Sicherheitsvorschriften elektrisch umpolen.
6. Nach Erreichen der Betriebsdrehzahl die Stromaufnahme messen und mit dem Motornennstrom auf dem Ventilator- bzw. Motortypenschild vergleichen.
7. Bei anhaltendem Überstrom Ventilator sofort abschalten.
8. Ventilator auf ruhigen Lauf prüfen. Sicherstellen, dass keine außergewöhnlichen Schwingungen und Vibrationen auftreten.
9. Motor auf untypische Geräusche prüfen.

9. Inbetriebnahme

Die Motoren sind für Dauerbetrieb S1 ausgelegt. Bei mehr als drei Anläufen pro Stunde ist die Eignung des Motors von Nicotra Gebhardt zu bestätigen.



Explosionsfähige Gasgemische können in Verbindung mit heißen und bewegten Teilen schwere oder tödliche Verletzungen verursachen.

Explosionsgefahr durch erhöhte Umgebungstemperatur!

1. Umgebungstemperatur beobachten.
2. Für ausreichende Kühlluftzufuhr sorgen.

9.1. Voraussetzungen für den Betrieb im Ex-Bereich

Ventilator im Ex-Bereich nur in Betrieb nehmen, wenn folgende Bedingungen erfüllt sind:

- ☑ Die Angaben auf dem Typenschild stimmen mit den Anforderungen des Ex-Einsatzbereichs vor Ort überein (Gerätegruppe, Ex-Kategorie(Ex-Zone), Gasgruppe, Temperaturklasse).
- ☑ Alle an den Ventilator gekoppelten Komponenten, von denen eine Zündgefahr ausgehen kann, haben die erforderliche Ex-Zulassung.
- ☑ Die Umgebungstemperatur beim späteren Einsatz liegt im erlaubten Bereich!
- ☑ Alle erforderlichen Schutzeinrichtungen sind installiert.
- ☑ Das Laufrad ist gegen Berührung und vor dem Auftreffen fallender oder angesaugter Gegenstände geschützt.
- ☑ Der Ventilator wird nicht in staubiger Umgebung betrieben.
- ☑ Es ist sichergestellt, dass sich auf dem Ventilator keine unzulässigen Staubansammlungen bilden (Wartungsvorschriften beachten).
- ☑ Die Abstände vom Laufrad zu den bauseitigen Anlagenteilen sind geprüft und entsprechen den Explosionsschutzanforderungen.
- ☑ Der Ventilator ist ordnungsgemäß geerdet.

9.2. Ventilator in Betrieb nehmen



Verletzungsgefahr durch rotierende Teile und heiße Oberflächen!

1. Sicherstellen, dass alle Schutzvorrichtungen angebracht sind.
2. Sicherstellen, dass das Laufrad entsprechend DIN EN ISO 13857 abgesichert ist.

Inbetriebnahme

1. Funktion aller angeschlossenen Regelorgane prüfen.
2. **Ventilator einschalten.**

10. Instandhaltung

10.1. Sicherheitshinweise zur Instandhaltung

- ▶ Sicherheitshinweise und Schutzmaßnahmen in Kapitel 4 sowie die gültigen gesetzlichen Vorschriften beachten.
- ▶ Die Vorschriften des Motorherstellers sowie Angaben der Hersteller der Schalt- und Steuergeräte beachten



Nur bei gesicherter Netztrennung am Ventilator arbeiten!

Sachschaden durch Hochdruckreiniger!

VORSICHT

- ▶ Keine Hochdruckreiniger (Dampfstrahlreiniger) verwenden.

VORSICHT

Störung und Gefährdung durch austretende Fördermedien.

- ▶ Undichte Stutzen austauschen.

10.2. Regelmäßige Kontrollintervalle durchführen

Zur Aufrechterhaltung des Betriebes und der Sicherheit, empfehlen wir die Ventilatoren in regelmäßigen Abständen auf ihre Funktion und Beschaffenheit von fachlich qualifiziertem Wartungspersonal oder einer Fachfirma prüfen zu lassen und dies zu dokumentieren. Art, Umfang und Wartungsintervalle, sowie darüber hinaus erforderliche Tätigkeiten sind in Abhängigkeit des Einsatzes der Ventilatoren sowie der vor Ort vorherrschenden Bedingungen festzulegen. Die Wartungs- und Prüfungsempfehlung in Anlehnung an die VDMA 24186-1 finden Sie auch auf unserer Internetseite.

10.3. Instandhaltung vorbereiten

1. Motor vom Netz trennen.
2. Bei Ventilator mit geprüfem Revisionsschalter, Motor mit Revisionsschalter abschalten.
3. Ventilator gegen unbeabsichtigtes Einschalten sichern.
4. Warten, bis das Laufrad steht.
5. Warten, bis alle heißen Oberflächen kalt sind.
6. Alle Reststoffe im Ventilator entfernen.
7. Je nach Einbausituation Anlagenteile demontieren.

Instandhaltung vorbereitet

10.4. Wartungsempfehlung für Ventilatoren RLM-ATEX

Tabelle 10-1:

Wartungsempfehlung

- ▶ Ggf. Probelauf durchführen (siehe Kapitel 8.4.).
- ▶ Durchgeführte Kontrollintervalle dokumentieren.

	Beschreibung	¼ jährl.	periodisch	Bedarf
1.0	Ventilator			
1.1	Auf Verschmutzung, Beschädigung, Korrosion und Befestigung prüfen	X		
1.2	Laufrad auf Beschädigung und Unwucht prüfen, Schwingungsmessung	X		
1.3	Axialen und radialen Spalt prüfen	X		
1.4	Flexible Verbindungen auf Dichtheit prüfen	X		
1.5	Schwingungsdämpfer auf Funktion prüfen	X		
1.6	Schutzeinrichtungen auf Funktion prüfen	X		
1.7	Entwässerung auf Funktion prüfen	X		
1.8	Funktionserhaltendes Reinigen	X		
1.9	Laufraddrehrichtung prüfen (in allen Drehzahlstufen)	X		
2.0	Ventilator auf Funktion und Betriebsbereitschaft prüfen		X	
2.1	Motor	¼ jährl.	periodisch	Bedarf
2.2	Äußerlich auf Verschmutzung, Beschädigung, Korrosion und Befestigung prüfen	X		
2.3	Drehrichtung prüfen	X		
2.4	Lager auf Geräusch prüfen	X		
2.5	Lager schmieren (bei nachschmierbarer Ausführung)		X	
2.6	Schutzeinrichtung auf Funktion prüfen	X		
2.7	Anschlussklemmen auf festen Sitz prüfen	X		
2.8	Funktionserhaltendes Reinigen	X		

10.4.1 Schwingungsüberprüfung

Der Ventilator ist regelmäßig auf mechanische Schwingungen zu überprüfen. Die maximal zulässigen Schwinggeschwindigkeiten sind der ISO 14694 angelehnt.

Tabelle 10-2:
Schwinggeschwindigkeit

Ventilator mit Schwingungsdämpfern		Ventilator ohne Schwingungsdämpfer	
Motorleistung	Schwing- geschwindigkeit	Motorleistung	Schwing- geschwindigkeit
≤ 3,7 kW	9,0 mm/s	≤ 3,7 kW	5,6 mm/s
> 3,7 kW	6,3 mm/s	> 3,7 kW	4,5 mm/s

Die Schwinggeschwindigkeiten werden in radialer Richtung an den Lagern bzw. am Lagerschild des Motors gemessen.

Eine Laufradverschmutzung kann Unwucht und Beschädigung hervorrufen. Um diesen Gefahren vorzubeugen, sind je nach Einsatz geeignete Inspektions- und Reinigungsintervalle einzuhalten.

10.4.2 Motorlager

Die Lager des Motors sind werksseitig mit einer Dauerschmierung versehen; erfahrungsgemäß muss das Fett bei normalen Betriebsbedingungen erst nach mehreren Jahren erneuert werden.

Bei nachschmierbaren Motorlagerungen sind die Herstellerangaben zu beachten!

Bei Lagergeräuschen ist die Service-Abteilung von Nicotra Gebhardt zur Überprüfung oder zum Austausch der defekten Lager zu beauftragen.

10.4.3 Stillstandzeiten

Bei längeren Stillstandszeiten ist der Ventilator regelmäßig kurzzeitig in Betrieb zu nehmen um Lagerschäden durch statische, mechanische Belastung oder Eindringen von Feuchtigkeit zu vermeiden.

Nach längerer Lagerung sind vor dem Einbau die Lager zu überprüfen.

Lässt der Zustand des Ventilators eine Instandsetzung durch geeignete Maßnahmen nicht mehr zu, ist der Ventilator unverzüglich außer Betrieb zu setzen und ggf. zu erneuern.

11. Störungen

Treten während des Betriebs Störungen auf, die nicht vom Wartungspersonal behoben werden können, bitte Kontakt mit der Service-Abteilung der Nicotra Gebhardt GmbH aufnehmen.



Explosionsgefahr durch unzulässige Betriebszustände!

- ▶ Bei Überschreitung der zulässigen Werte, Unregelmäßigkeiten oder auffälligen Störungen Ventilator sofort abschalten.

12. Service, Ersatzteile und Zubehör

Nicotra Gebhardt GmbH
Gebhardtstraße 19–25
74638 Waldenburg
Germany

Fon: +49 (0) 7942 101 384
Fax: +49 (0) 7942 101 385
Mail: info@nicotra-gebhardt.com
Web: www.nicotra-gebhardt.com

12.1. Ersatzteile bestellen

- ▶ Nur Original-Ersatzteile der Nicotra Gebhardt GmbH entsprechend der Ersatzteilliste verwenden.

Der Einbau von Ersatzteilen anderer Fabrikate kann die Sicherheit beeinträchtigen.

Für Schäden und Folgeschäden, die durch Verwendung von Ersatzteilen anderer Fabrikate entstehen, übernimmt die Nicotra Gebhardt GmbH keinerlei Haftung oder Gewährleistung.

Ersatzteile online bestellen - www.nicotra-gebhardt.com/Partshop

12.2. Zubehör

Die Nicotra Gebhardt GmbH bietet ein breites Zubehörprogramm zum wirtschaftlichen Einsatz der Ventilatoren.

Das Zubehör ist optional und immer separat zu bestellen.

Die Auswahl erfolgt über die technische Dokumentation oder unser elektronisches Auswahlprogramm.

Für die Montage bzw. Anwendung ist das Zubehör, soweit nicht selbsterklärend, mit separaten Bedien- oder Montagehinweisen versehen.

13. Anhang

13.1 Weitere Dokumentation der Nicotra Gebhardt GmbH

Tabelle 13 1: Weitere Dokumentation

Art der Dokumentation	Ort der Dokumentation
Wartungs- und Prüfeempfehlungen	Internet
EU-Konformitätserklärung 2014/34/EU (ATEX)	Anhang
EG-Einbauerklärung	Anhang

EU-Konformitätserklärung zur EU-Richtlinie 2014/34/EU (ATEX)

Hersteller:	Nicotra Gebhardt GmbH, Gebhardtstraße 19-25, 74638 Waldenburg, Germany
	erklärt hiermit, dass die nachfolgend bezeichnete Maschine aufgrund ihrer Konzipierung und Bauart sowie in der von uns in Verkehr gebrachten Ausführung den einschlägigen grundlegenden Sicherheits- und Gesundheitsanforderungen der unten angeführten EU-Richtlinie entspricht.
Bezeichnung:	Radialventilator mit Direktantrieb ohne Gehäuse der Kategorie 2G, zur Förderung explosionsfähiger Atmosphäre
Maschinentyp:	RLM 55-....-2G ; RLM 56-....-2G; RLM E6-.... -Y-...; RLM E3-.... -Y-...; RLM G6-.... -Y-....
Kennzeichnung:	II 2G Ex h IIB T4 Gb ; II 2G Ex h IIB+H2 T4 Gb
Seriennummer:	siehe Typenschild
Baujahr:	siehe Typenschild
Einschlägige Richtlinien:	EU-Richtlinie 2014/34/EU (ATEX)
Hinterlegungsbescheinigung:	EX9 12 10 78300 006 (RLM E6 + RLM G6) EX9 14 11 78300 007 (RLM E3) EX9 11 09 78300 003 (RLM 55/56)
Notifizierte Stelle:	TÜV SÜD Product Service; Zertifizierstelle; Ridlerstraße 65; 80339 München; Germany;
Angewandte, harmonisierte Normen ¹⁾ , insbesondere:	DIN EN 1127-1, DIN EN 14986 , DIN EN 60079-0, DIN EN ISO 80079-36, DIN EN ISO 80079-37

Diese Konformitätserklärung ist nur für den werksseitig montierten, mit Antrieb versehenen und geprüften Ventilator gültig. Bei Änderungen am Ventilator ist die Konformität neu zu bestätigen.

Der Hersteller trägt die alleinige Verantwortung für die Ausstellung dieser Konformitätserklärung.

Waldenburg, den 20.01.2019



i.V. T. Ehrhardt
Produktionsleiter



i.V. Dr. J. Anschütz
Leiter Forschung & Entwicklung

¹⁾ Die vollständige Liste der angewandten Normen und technischen Spezifikationen siehe Herstellerdokumentationen.

EG-Einbauerklärung

Hersteller: **Nicotra Gebhardt GmbH**,
Gebhardtstraße 19-25, 74638 Waldenburg, Germany

erklärt hiermit, dass folgendes Produkt:

Bezeichnung: **Radialventilator mit Direktantrieb ohne Gehäuse der Kategorie 2G, zur Förderung explosionsfähiger Atmosphäre**

Maschinentyp: **RLM 55-....-2G ; RLM 56-....-2G;
RLM E6-.... -Y-... ; RLM E3-.... -Y-... ; RLM G6-.... -Y-...**

Seriennummer: siehe Typenschild

Baujahr: siehe Typenschild

als unvollständige Maschine gilt im Sinne von Artikel 2, Absatz „g“ und den folgenden grundlegenden Anforderungen der **Richtlinie Maschinen (2006/42/EG)** entspricht: **Anhang I, Artikel 1.1.2, 1.3.7.**

Die unvollständige Maschine darf erst dann in Betrieb genommen werden, wenn festgestellt wurde, dass die Maschine, in die die unvollständige Maschine eingebaut werden soll, den Bestimmungen der Richtlinie Maschinen (2006/42/EG) entspricht.

Folgende harmonisierte Normen¹⁾ wurden angewandt:

DIN EN ISO 12100 Sicherheit von Maschinen - Allgemeine Gestaltungsleitsätze

DIN EN ISO 13857 Sicherheit von Maschinen – Sicherheitsabstände gegen das Erreichen von Gefährdungsbereichen

Angewandte, nationale Normen und technische Spezifikationen²⁾ insbesondere:

VDMA 24167: Ventilatoren – Sicherheitsanforderungen

Der Hersteller verpflichtet sich, die speziellen Unterlagen nach Anhang VII, Teil B zur unvollständigen Maschine einzelstaatlichen Stellen auf Verlangen per Post/E-Post zu übermitteln.

Waldenburg, den 20.01.2019

Bevollmächtigter für die technische Dokumentation: Michael Hampel



i.V. T. Ehrhardt
Produktionsleiter



i.V. Dr. J. Anschütz
Leiter Forschung & Entwicklung

¹⁾ Die Vollständige Liste der angewandten Normen und technischen Spezifikationen siehe Herstellerdokumentation

²⁾ Sofern noch keine entsprechende harmonisierten Normen vorliegen

NICOTRA || **Gebhardt**
fan|tastic solutions

Nicotra Gebhardt GmbH
Gebhardtstraße 19-25
74638 Waldenburg
Germany

Fon: +49 (0)7942 101 0
Fax: +49 (0)7942 101 170
Mail: info@nicotra-gebhardt.com

Web: www.nicotra-gebhardt.com

Operating Instructions

ATEX - Plug fans

(Translation of the original)

EN



II 2G Ex h IIB(+H2) T4 Gb

BA-CFD-RLM-ATEX 4.0 – 05/2019

		<p>RLM E6 RLM E3 RLM G6</p>
		<p>RLM 55 RLM 56</p>

NICOTRA||**Gebhardt**

fan|tastic solutions

Contents

Contents	EN-2
1. Revision Index.....	EN-2
2. About This Operating Manual	EN-3
3. Designated Use.....	EN-5
4. Safety	EN-7
5. Product Description	EN-10
6. Transport and Storage	EN-11
7. Installation	EN-12
8. Electrical Connection.....	EN-15
9. Commissioning.....	EN-17
10. Maintenance.....	EN-18
11. Faults.....	EN-20
12. Service, Spare Parts and Accessories.....	EN-21
13. Annex	EN-21
EU Declaration of Conformity to EU Council Directive 2014/34/EU (ATEX).....	EN-22
EC-Declaration of Incorporation	EN-23

Further languages on request!

1. Revision Index

Table 1-1: Revision Index

Revision	Datum
BA-CFD-RLM-ATEX 3.1 – 08/2011	08/2011
BA-CFD-RLM-ATEX 3.2 – 03/2012	03/2012
BA-CFD-RLM-ATEX 3.3 – 01/2013	01/2013
BA-CFD-RLM-ATEX 3.4 – 03/2013	03/2013
BA-CFD-RLM-ATEX 3.5 – 06/2014	06/2014
BA-CFD-RLM-ATEX 3.6 – 12/2014	12/2014
BA-CFD-RLM-ATEX 3.7 – 03/2015	03/2015
BA-CFD-RLM-ATEX 3.8 – 12/2015	12/2015
BA-CFD-RLM-ATEX 3.9 – 04/2016	04/2016
BA-CFD-RLM-ATEX 4.0 – 05/2019	05/2019

2. About This Operating Manual



These operating instructions are an integral part of the fan. Nicotra Gebhardt GmbH shall not accept any liability or provide any warranty cover for primary damage or secondary damage arising as a consequence of disregarding these operating instructions.

- ▶ Read the operating manual carefully before use.
- ▶ Retain the operating manual for the entire service life of the fan.
- ▶ Keep the operating manual accessible to personnel at all times.
- ▶ Pass the operating manual on to any subsequent owner or user of fan.
- ▶ Insert any supplementary instructions received from the manufacturer into the operating manual.

2.1. Validity

This operating manual only applies to the fans stated on the front page

2.2. Target Group

This operating manual is intended for operators and qualified professionals trained in installation, commissioning, operation, maintenance and decommissioning.

2.3. Other Applicable Documents

- ▶ **In addition to reading these instructions, due notice should also be taken of the type plate, warning signs, indicating label on the fan and the following documents and specifications:**
 - VDE 0100-100
 - EN 60204-1
 - EN ISO 13857
 - EN ISO 12100
 - EN ISO 13732-1
 - EN ISO 80079-36; -37
 - EN 1127-1
 - EN 60079-0
 - EN 14986
 - Technical catalogue
 - EU-Directive 2014/34/EU

2.4. Symbols und Markings

2.4.1. Use of Warning Signs





Signal word

Nature, source and consequences of hazard!

- ▶ Steps required to avert danger

2.4.2. Levels of Danger in Warning Signs

Table 2-1: Levels of danger in warning signs

Symbol / Danger Level	Likelihood of Occurrence	Consequences of Neglect
 <p>DANGER!</p>	Imminent danger	Death, serious physical injury
 <p>WARNING!</p>	Potential danger	Death, serious physical injury
 <p>CAUTION!</p>	Potential danger	Minor physical injury
<p>CAUTION</p>	Potential danger	Damage to property

2.4.3. Notes

Note Note giving pointers for easier or safe work.

- ▶ Steps required for easier or safe work.

2.4.4. Other Symbols and Markings

Table 2-2: Other symbols and markings

Symbol	Meaning
☑	Requirement for an operation
▶	Operation with one step
1. 2. 3.	Operation with several steps
•	Bullet point (primary list)
-	Bullet point (secondary list)
Accentuation (bold)	For emphasis

3. Designated Use

3.1. Operating Data / Maximum Ratings



Risk of injury!

- ▶ Adhere to the technical specifications and permissible limits.

For technical specifications please refer should be made to the type plate, technical data sheet and technical catalogue.

Note ATEX category II 2G Ex h IIB T4 Gb

Fans of this category are designed for areas where an explosive atmosphere – as a mix of air, gases, vapors or mist - is likely to occur occasionally. The unit related measures for explosion protection of this category have to offer the necessary amount of safety, even in the case of frequent unit troubles or failure modes, to be usually anticipated (predictable troubles). For the operation of the fans in explosion hazardous areas the relevant prescriptions, local regulations and directives (ATEX 2014/34/EU) for manufacturers and user have to be respected.



The installation is authorized in a horizontal shaft position only

Table 3-1:
Maximum ratings

Permissible conveyed medium temperatures (ATEX)

Range	Perm. temperature of conveyed medium	Max. ambient temp. on drive motor
RLM 55/56/G6/E6/E3	-20°C ... +40°C (60°C)	+ 40°C (60°C)

3.1.1 Examples of incorrect use include the following:

- Extraction of media with impermissibly high or low temperatures
- Extraction of corrosive media
- Extraction of very dusty media

3.1.2 The results are:

- Bearing damage
- Corrosion damage
- Loss of balance
- Vibration
- Deformation
- Abrasion damage

CAUTION Unauthorised operation

- No operation above the indicated rpm (see type plate, data sheet)
- No operation at rpm ranges with increased vibration (resonance)
- No operation at rpm ranges out of permitted fan curve area (stability of flow pattern).
- No operation if fan becomes polluted



Danger points:
 There can be injury to personnel and material damage through impeller breakage, shaft breakage, fatigue failure, fire (explosions) from spark creation.

3.2. Explosion Protection Markings

The marking on the type label of the explosion proof fans includes the group, category, ignition class and temperature class as well as a CE-Ex-sign thus confirming the conformity to the European directive 2014/34/EU. The manufacturer’s declaration and the declaration of conformity 2014/34/EU (ATEX) are attached to this maintenance instructions.

Directive Part I Standard Part
CE **Ex** **II 2 G Ex h IIB(+H2) T4 Gb**

| | | | | | | | | |
A B 1 2 3 4 5 6 7 8

Fig 3-1: Explosion protection markings (example)

A	CE-Mark	
B	Hazardous duty marking	
1	Machine group II	Non-electric machines for use outside of the mining industry and underground mining
2	Machine category 2	(internal and external) for use in Zones 1+2; An explosive atmosphere is only present in the area occasionally
3	Conveyed medium G	Gaseous conveying medium
4	Ex-symbol	ac. EN ISO-Norm 80079-36
5	Replacement ignition protection h	Explosion protection by design safety
6	Explosion group IIB (+H2)*	Type of gas atmosphere
7	Temperature class T4	Max. Surface temperature at the device + 135 ° C
8	Equipment protection level Gb	For gas in zone 1 - Gb (in zone 2 - Gc)

* (+ H2) is valid only for RLM E6, RLM G6 and RLM E3:
 For hydrogen-containing gas mixtures with max. 4% hydrogen (LEL);
 Prerequisite is a material pairing between the rotating parts in steel - copper and the use of an Ex de IIC T4 motor

4. Safety

4.1. Product safety

The fans offer a high degree of operational safety and high quality standards guaranteed by a certified Quality Management System (EN ISO 9001). Before leaving the factory all the fans are inspected and sealed with a mark of conformity.

Nevertheless, when operating fans supplied by Nicotra Gebhardt GmbH there can be a risk of death or injury for the user or third parties, and a risk of damage to the fan or other material assets.

- Only use the fans in perfect working order and for its designated use as intended, having due regard for safety, an awareness of hazards and in due compliance with the operating instructions.
- Arrange immediate repair of any faults which could compromise safety.



Potentially explosive gas mixtures in conjunction with hot and moving parts may cause serious or fatal injury.

Risk of explosion due to increased ambient temperature!

1. **Observe ambient temperature**
2. **Ensure adequate supply of cooling air**

4.2. Safety Instructions

The fan may only be commissioned, operated and serviced in compliance with the following instructions:

- Operating instructions
- Warning and information signs on the fan
- Any other operating and installation instructions pertaining to the machine
- Terms and requirements relevant to the machine
- Applicable national and regional regulations, especially regarding explosion protection, health & safety and accident prevention.

4.3. Safety Devices

1. Use appropriate safeguards to prevent contact with rotating parts (shafts, impeller, etc.).
2. Protection devices are so selected so that sucking or falling-in of objects will be prevented.
3. After installation (and before electrical connection) immediately refit any guards which have been removed during installation.



The fans are delivered with inlet guards. If there is a danger of contact with the impeller owing to the way the fan is installed, then it is necessary to fit guards conforming to EN ISO 13857. Only then can the fan be set in operation!



**ATEX fans of categories 2G or 3G are made for integration into installations. Care must be taken to avoid any ingress of object into the fan. (min. IP20 to EN 60529).
The user has to find corresponding protection in order to ensure a safe operation!**



The suitability of protection devices and their fixtures to the fan have to be evaluated within the overall security concept of the installation.

4.4. Professional Staff

1. Ensure that the Installation of the fan and any work on it is carried out by skilled professionals only with due regard to these operating instructions and any applicable regulations.
2. Electrical connection to be carried out by qualified electricians only.

4.5. Protective Gear



**Ensure that members of staff are wearing protective gear appropriate to their deployment and environment.
The protective clothing is specified below!**

4.6. Specific Hazards

4.6.1. Noise Emission



The sound emission expected during normal use of the fan is documented in the technical lists and should be duly taken into account.

- ▶ **Wear ear defenders when working near to or on the running fan!**

4.6.2. Heavy Loads

The heavy weight of the fan and its components entail the following risks in transit and during installation (deinstallation):



- Risk of being trapped, crushed or cut by moving or toppling machinery
- Danger of falling components

- ▶ **Do not stand or work under suspended loads.**
- ▶ **Wear a hard hat, safety shoes and gloves.**

4.6.3. Rotating Shafts and Impellers

Objects falling onto rotating shafts and impellers can fly off at an angle and cause serious injury.

Articles of clothing and hair can get caught in rotating shafts and impellers.



- ▶ **Do not remove guards during operation.**
- ▶ **Do not wear loose-fitting clothing when working near rotating shafts and impellers.**
- ▶ **Wear goggles.**

4.6.4. Hot Surfaces

There is a risk of sustaining burns or scalds on hot surfaces during operation.



- ▶ Do not touch the motor during operation.
- ▶ When the fan has stopped wait until the motor has cooled down.
- ▶ Wear protective gloves.

4.7. Structural Modifications, Spare Parts

Note Unauthorised structural modifications may not be made to the fan without the consent of Nicotra Gebhardt GmbH. Nicotra Gebhardt GmbH shall not accept liability for any damage arising as a result such modifications. Use only genuine spare parts supplied by Nicotra Gebhardt GmbH.

CAUTION In areas subject to explosion hazards the fan may only be modified or converted by Nicotra Gebhardt GmbH itself, by a service location approved by the company, or by personnel authorised and trained by the company.

4.8. Installation and Maintenance

The following steps should be taken before working on the fan:

1. Ensure that the atmosphere is not potentially explosive.
2. Switch off the machine and take measures to prevent it from being switched back on accidentally.
3. Display the following message on a sign:
Do not switch on! Work currently in progress on the machine.

4.9. Signs on the Fan

Depending on the model, the type plate and the arrow indicating the direction of rotation are fitted to the fan for high visibility.

4.9.1. Type plate

Fig 4-1:
Example type plate

Nicotra Gebhardt		D-74638 Waldenburg		CE
Tel.: +49 (0)7942 101 384		Fax: -385		
E-Mail: service@nicotra-gebhardt.com				
RLM 56-3540-4Y-11-2G				
GERÄTE-Nr.	128-260549-220255/2	HERSTELLJAHR 2010		
VENTILATOR		MOTOR		
Dichte	= 1.2 kg/m ³	UN	= 400	V (D/Y)
T max	= 40 °C	FN	= 50	Hz
n max	= 1810	F max	= 64	Hz
			= 3.3 /1.88	A
			= 1395	1/min
			= 0.75	kW
			= P55	
		Wärmeklasse	= F	
		Stromart	= 3~	
Example!				
CE Ex II 2G Ex h IIB T4 Gb (int./ext.)				

4.9.2 Arrow Indicating Direction of Rotation

Fig 4-2: Arrow indicating direction of rotation

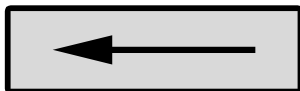

4.9.3 Terminal Board Circuit Diagram

Fig 4-3: Example circuit diagram

The wiring diagram is in the terminal box of the motor.

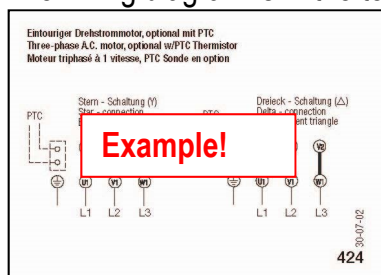

5. Product Description

5.1. Centrifugal fan RLM without housing, direct driven (Plug Fan)



Plug fans RLM are optimized for operation without scroll. Direct drive with IEC motor. The centrifugal impeller with backward-curved blades is fitted directly to the motor shaft. The fan unit consisting of impeller with inlet cone, motor block and base frame, installed and adjusted at the factory. The fans are equipped with a volometer and inlet guard as a standard.

Plug fans RLM are comply to the requirements of ATEX-Directive 2014/34/EU by designed safety and safe construction according to EN ISO 80079-36 and -37 and EN 14986. The classification of these fans is fitting into group II, category 2G, Explosion group IIB(+H2), Temperature class T4 (T3) and Equipment protection level EPL Gb.

Materials:

- **Impeller** made of sheet steel, ATEX special coated (etc.stainless steel)
- **Inlet cone** made of copper.

Note The ATEX fan must not be modified by the user. Any modification will render ATEX conformity invalid.

5.2. Centrifugal fan (Plug fan) RLM

5.2.1 Centrifugal fan direct driven RLM

RLM 55-1112/-1214

RLM 56-2528/-1011 / RLM E3 -2528/-6371
RLM G6-2225 / RLM E6-2528/-1011

Figure 5-1:
Ranges

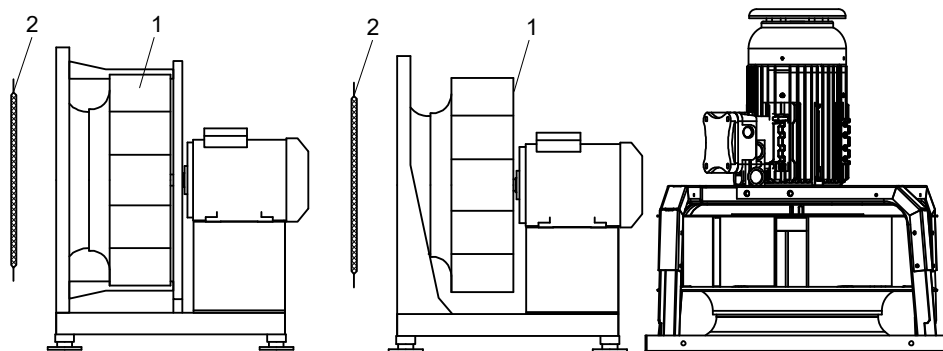

- 1. Fan
- 1. Inlet guard (included)
 - Safety of machinery EN ISO 13857
 - Degrees of protection EN 60529

6. Transport and Storage



6.1. Packaging

Fans are packaged in sturdy cardboard boxes or wooden crates depending on their size and weight. Instructions for removing transportation locks are enclosed.

6.2. Symbols on Packaging

The following symbols are printed on the cardboard boxes:

Table 6-1:
Symbols on packaging

Symbol			
Meaning	Handle with care	Keep dry	Top

6.3. Transportation of Plug fans



Danger of injury from falling components!

Use tested and appropriate load handling equipment only (see type plate or data sheet). Transport the fan in the original packaging for as long as possible. Secure the load

- **Do not stand under suspended loads**

1. Select means of transport according to weight and dimensions of fan. Fan must be attached at the base frame, base plate or supporting plate (For weights please see the technical catalogue)
2. Lift the fan by the base frame and/or by the carrier plate only
3. When using transport belts always provide 4 points of suspension (2 belts). The belt may not exert a deforming force on the fan or its packing. If necessary, use a spacer!
4. Secure load with belts or fix it against sliding!
5. Handle centrifugal fan with care to prevent damages avoid e.g. shock or rough placement

CAUTION These are NOT fixing points at the fan!

- Motor lifting ring bolt

- Impeller
- Inlet cone

6.4. Storage of Centrifugal Fan

CAUTION Risk of corrosion!

- ▶ Store the fan in its packaging adding any other protection dictated by its storage environment
- ▶ Store centrifugal fan in a well-ventilated room only at normal temperatures and in a non-corrosive atmosphere
- ▶ Store centrifugal fan in conditions registering less than 70 % atmospheric humidity (non-condensing)
- ▶ Adhere to max. permissible temperature of -20°C to +40°C

7. Installation

7.1. Safety Instructions for Installation

- ▶ Observe the safety instructions and preventive measures in Chapter 4 and the relevant legal requirements.

CAUTION The ATEX- fan system supplied by Nicotra Gebhardt must not be modified in any way! Its operation is exclusively permitted in it's state as originally supplied and within the LIMITS SPECIFIED. (Respect catalogue- and type plate data).

7.1.1. Installation notes

In order to achieve a sufficient motor cooling, care has to be taken that the fan at motor side is keeping a minimum clearance (L1) to the next wall. For disclosures on L1 refer to the motor operating instructions.

Figure 7-1:
Clearance

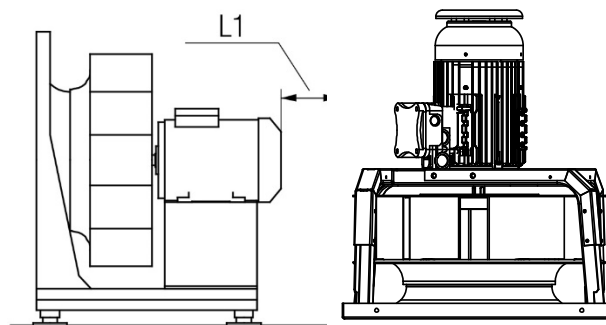

RLM E3: only vertical installation, with air direction from bottom to top, permissible. Minimum distance determined by motor protection cover.

7.2. Preparation to Installation

- The place of installation must be suitable for the fan in terms of its category, condition, ambient temperature and environmental media.
- The base must be level and have sufficient load-bearing capacity.
 1. Unpack centrifugal fan carefully.
 2. Unfasten or dismantle transport locks
 3. Packing material to be fully removed and disposed.
 4. Check gaps as per 7.4.

7.3. Carrying out the Installation

1. The fan or base frame must be fixed without stressing and free of forces to the supporting structure.
 2. loose fitted AVM to be regularly placed around centre of gravity and definitely fixed. Check whether the AVM is evenly under load.
 3. Ensure that the fan is earthed in accordance with regulations. The anti-vibration mounts themselves do not ensure electrical transmission.
- No forces or vibrations may be transferred from other plant parts to the fan (flexible connection)!
 - The flexible connections (ATEX) at intake and/or discharge are installed, well aligned, freely moving and earthed plant side.
 - The AVM are freely moving and under even load!
- The impeller is turning idly and does not touch the intake cone! (Note minimum gap, see 7.4)!
 - The distances from the impeller to the plant parts on site are checked and meet the requirements for explosion protection.
 - The stability of the fan against collapse of the fan has been checked.

7.4 Checking the Gap Dimension on the Fan

- ▶ Check gap between impeller and inlet cone and between impeller border and pressure measuring nipple of the volumeter against chart values below!

Figure 7-2: Gap width

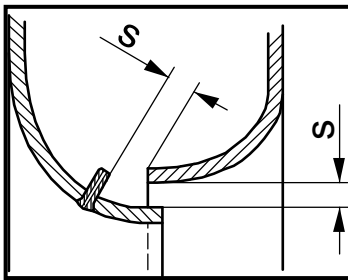
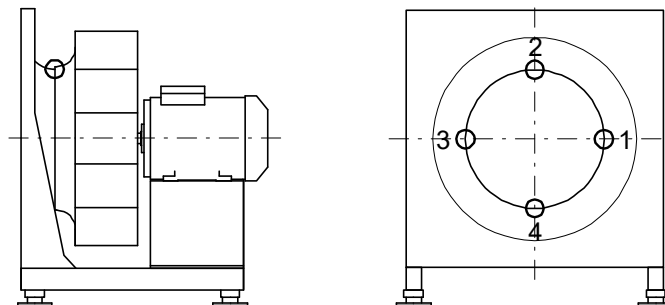

Table 7-1: Gap width

RLM	Gap width „s“	RLM	Gap width „s“
2225	2,0	5663	4,3
2528	2,0	6371	4,8
2831	2,2	7180	5,4
3135	2,4	8090	6,0
3540	2,7	9010	6,7
4045	3,0	1011	7,5
4550	3,4	1112	8,5
5056	3,8	1214	9,5

Figure 7-3: Measured points



1. Measure the gap and ensure that the width of the gap does not fall below the threshold in any phase of the rotation (manual rotation).
2. Carry out measurements on four 90° points on the circumference. Ensure that the gauge is placed on the outer diameter of the inlet cone.

7.5 Volumeter

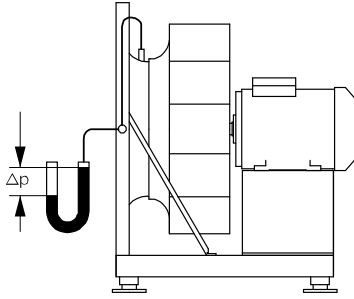

The fans are equipped with a volumeter as a standard. With this flow measuring device it is possible to measure/monitor the flow easily after the fan is installed.

- Measuring nipple on intake cone
- piping to connector at support unit
- connector (external diameter 6mm) to pressure measuring device

Figure 7-4: Volumeter

$$qv = K \times \sqrt{\frac{2}{\rho} \times \Delta p_{Dü}}$$

- qv volume flow [m³/h]
- K calibration factor [m²s/h]
- ρ density of media [kg/m³]
- Δp_{Dü} pressure difference at cone [Pa]

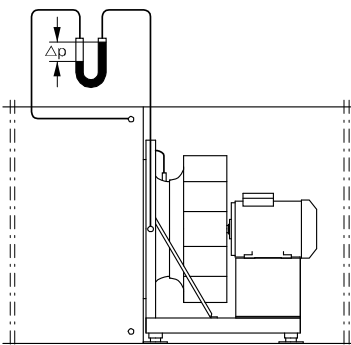

Figure 7-5 :Built in fan

When fans are built in a plenum, it is required to measure the differential pressure between the static pressure in the plenum on the suction side and the pressure at the inlet cone.

To ensure that the static pressure to be measured at the inlet nozzle is not distorted by dynamic velocities, it is recommended to attach a ring-line of measuring points on the wall as shown in the following diagram.

When using a differential pressure sensor, the signal can be used for automatic control purpose.

For calculation of the flow rate a calibration coefficient (K-factor) for every fan required this is determined by comparative measurement on a standard test rig with none disturbed air flow at suction.

K-Factor deviation
Standard calibration
K10 < 10%

RLM E6- E3-G6	Calibration factor K10	RLM 56- 55-	Calibration factor K10
2225	73 m²s/h	2528	73 m²s/h
2528	79 m²s/h	2831	90 m²s/h
2831	94 m²s/h	3135	105 m²s/h
3135	106 m²s/h	3540	120 m²s/h
3540	128 m²s/h	4045	150 m²s/h
4045	155 m²s/h	4550	190 m²s/h
4550	190 m²s/h	5056	240 m²s/h
5056	242 m²s/h	5663	300 m²s/h
5663	310 m²s/h	6371	385 m²s/h
6371	385 m²s/h	7180	485 m²s/h
7180	490 m²s/h	8090	620 m²s/h
8090	628 m²s/h	9010	790 m²s/h
9010	794 m²s/h	1011	1000 m²s/h
1011	1017 m²s/h	1112	1260 m²s/h
		1214	1540 m²s/h

7.6 Install Protection Devices

1. Fit guards to protect exposed inlet openings (EN ISO 13857).
2. Design safety devices in such a way that they prevent objects from being sucked in or from falling in (see EN 60529).

8. Electrical Connection

8.1. Safety Instructions for Electrical Connection



Danger of electric shock!

- ▶ Observe the safety instructions and preventive measures in Chapter 4 as well as the relevant legal requirements.
- ▶ EN 60204-1, IEC 60364-1 / VDE 0100-100; EN 60079-0, VDE 0170-1; EN 60079-14, VDE 0165-1.

All fans are delivered ready for connection. The terminal box is easily accessible. The wiring diagram is in the terminal box. Protection systems are provided by the customer and are not supplied by Nicotra Gebhardt.

No mains connection operation allowed for models with max. operating frequency <50 Hz!

Note As a standard feature the fans are suitable for operation by a frequency inverter. When operating the fans together with frequency inverter or control equipment containing electronic components the manufacturer's recommendations are to be observed concerning radio noise suppression (EMC) (through suitable earthing, cable lengths, cable screening, etc.).

CAUTION **Inspection switches, electronic control units and frequency converters can cause material damage!**

- ▶ Do not use electronic control units or frequency converters in areas subject to explosion hazards.
- ▶ Install inspection switches - except inspection switches approved for areas subject to explosion hazard – outside the area subject to explosion hazards.

Note The standard motors are classified as protection category "Explosion proof Ex de II", temperature class T4, for ambient temperature from -20°C to +40°C (60°C) in accordance with Directive 2014/34/EU (ATEX) and IEC/EN 60079-0, IEC/EN 60079-1.

- ▶ Current, voltage and frequency of mains supply checked for conformity with fan type plate and motor rating plate.
- ▶ Star-delta or soft start provided for motors with a nominal output >4 kW.
- ▶ Adhere to the output limits imposed by the power supply company.
- ▶ If necessary, an Isolator must be provided (outside the area subject to explosion hazards)
- ▶ All components are provided with an earthing. The fan components are electrically connected to each other.
- ▶ **The fan is protected against unexpected start!**
- ▶ **Chapter 4. „Safety“ must be respected!**

8.2. Electrical connection of the motor

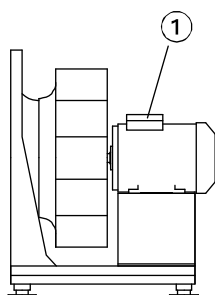

Figure 8-1 Connection box

1. Fit inspection switch if applicable.
2. Connect feed line to fan or service switch.
3. Connect motor as shown on connection diagram supplied.
4. Ensure that all the electrical safety devices have been fitted and connected.

1 = Connection box

8.3. Motor Protection

Protect motors against overload in accordance with EN 60204-1.

- Speed controlled, pressure resistant encapsulated motors, equipped with certified PTC-thermistors have to be operated – in the case of explosion proof application – with an ATEX certified tripping unit, which switches off the fan at a surface temperature of 125 ° C!
- Only motors conforming to the corresponding ATEX – category of the fan are permitted.
- Motor protection switches must be set to the nominal motor current (see type plate). A higher setting value is not admitted!
- Respect the te-time for overload protection indicated on the motor type plate.

CAUTION Fuses or circuit breakers do not provide sufficient motor protection. Damage due to insufficient motor protection invalidates the manufacturer's guarantee.

Note In all cases the power limitations provided by the existing power supply company must be taken into account.

If plant conditions necessitate a direct start the suitability of the fan design must be confirmed with Nicotra Gebhardt. Fans with high inertia impellers can take over 6 seconds to reach top running speed. In these cases heavy duty motor protection relays or bimetal relays must be provided.

8.4. Carrying out a Test Run



Risk of injury from rotating impeller!

- ▶ Never reach into the impeller when the fan is open.

1. Take measures to prevent the centrifugal fan from being switched on accidentally
2. Clear the ducting system and fan of all foreign bodies (tools, small parts, construction waste, etc.
3. Close all the inspection openings.
4. Switch on the fan and check the direction of rotation of the impeller by comparing it with the arrow on the fan indicating the direction of rotation.

5. If the direction of rotation is wrong, reverse the polarity of the motor having due regard to the safety instructions.
6. Once operating speed has been reached measure the current consumption and compare it with the nominal motor current on the fan type plate or motor rating plate
7. If there is continuous overload switch the fan off immediately.
8. Check that the fan runs smoothly and quietly. Ensure that there are no unusual oscillations or vibrations.
9. Check the motor for any abnormal noises.

9. Commissioning

The motors are designed for continuous operation S1. If operations involve more than three starts per hour Nicotra Gebhardt GmbH shall be required to confirm the suitability of the motor.



Potentially explosive gas mixtures in conjunction with hot and moving parts may cause serious or fatal injury.

Risk of explosion due to increased ambient temperature!

1. **Observe ambient temperature.**
2. **Ensure adequate supply of cooling air.**

9.1. Conditions for Commissioning in Ex-Area

The following requirements must be met before operating the fan in areas subject to explosion hazards:

- Specifications on the type plate to meet the standards required in the local operating conditions in respect of explosion hazards (device group, explosion hazard category (hazard zone), gas group, temperature class).
- All the components connected to the fan carrying a risk of ignition or explosion to have the required approval certificates.
- The ambient temperature during subsequent use to be within in the allowed limits!
- All the requisite safety devices to be installed.
- Prevent impeller from contact and from being hit by falling or sucked-in objects.
- The fan is not operated in a dusty environment.
- Ensure that unacceptable levels of dust are not allowed to gather on the fan. (Note maintenance instructions.)
- The distances from the impeller to the plant parts on site are checked and meet the requirements for explosion protection.
- Ensure that the fan is earthed in accordance with regulations.

9.2. Commissioning the Centrifugal Fan



Risk of injury from rotating parts and hot surfaces!

1. Ensure that all the safety devices are fitted.
2. Ensure that the impeller has been secured acc. to EN ISO 13857!

Commissioning

1. Check the working order of all the connected control instruments.
2. **Switch on the centrifugal fan.**

10. Maintenance

10.1. Safety Instructions for Maintenance

- ▶ Observe the safety instructions and preventive measures in Chapter 4 as well as the relevant legal requirements.
- ▶ Follow the directions of the motor supplier and the instructions specified by the manufacturers of the switches and control units.



WARNING!

Work on the fan is only permitted when the power supply is fully cut!

CAUTION

Pressure washers can cause damage to property!

- ▶ **Do not use pressure washers (steam jet cleaners) to clean the equipment.**

CAUTION

Breakdown and hazard because of leaking gas media.

- ▶ **Exchange leak flexible connections.**

10.2. Observing Regular Inspection Intervals

In the interests of upkeep and safety we recommend having the operation and condition of the fans inspected at regular intervals by duly qualified service personnel or a professional maintenance firm and documenting these inspections. The nature and extent of the maintenance work, the service intervals and any additional work required needs to be specified on a case-by-case basis depending on the use of the fans and the general conditions on site. Our servicing and inspection recommendations based on VDMA 24186-1 can be found on our website.

10.3. Preparing for Maintenance

1. Disconnect the motor from the mains.
2. Plug fans fitted with a certified inspection switch should be switched off using the inspection switch.
3. Take measures to prevent the centrifugal fan from being switched on accidentally.
4. Wait until the impeller has stopped.
5. Wait until all hot surfaces have cooled down.
6. Remove any residues from the fan.
7. Depending on the situation installation components may be dismantled for inspection and maintenance.

Preparation for maintenance is completed

10.4 Maintenance recommendations for Fans RLM-ATEX

Table 10-1: Maintenance recommendation

- ▶ Conduct test run if applicable (see Chapter 8.4).
- ▶ Document inspection intervals observed.

	Description	quarterly	cyclic	on demand
1.0	Fan			
1.1	Check deposit, damages, corrosion and fixing	X		
1.2	Check impeller for damage and unbalancing, vibration check	X		
1.3	Check the axial and radial gap	X		
1.4	Check flexible connections for tightness	X		
1.5	Check correct function of AVM	X		
1.6	Check correct function of safety devices (guards)	X		
1.7	Check condensate water drain	X		
1.8	Clean entire unit in order to keep all elements in best working conditions	X		
1.9	Check rotational sense of impeller (for all speeds)	X		
2.0	Check fan function and its readiness for immediate start up		X	
2.1	Motor			
2.2	Visual control for dirt, damages, corrosion and correct fixing	X		
2.3	Check rotational sense	X		
2.4	Check bearing noise	X		
2.5	Lubricate bearing (where bearings are re-lubricable)		X	
2.6	Check correct function of safety devices (guards)	X		
2.7	Check tight electrical connections on tight fixing	X		
2.8	Clean entire unit in order to keep all elements in best working conditions	X		

10.4.1 Vibration monitoring

The fan has to be frequently checked for vibrations. The max. vibration velocity values admitted are those which relate to ISO 14694.

Table 10-2: Vibrations

Fan with AVM		Fan without AVM	
Motor power	Vibration velocities	Motor power	Vibration velocities
≤ 3,7 kW	9,0 mm/s	≤ 3,7 kW	5,6 mm/s
> 3,7 kW	6,3 mm/s	> 3,7 kW	4,5 mm/s

These vibration velocities are to be measured in a radial direction on the bearing or bearing casing of the motor.

Deposits of dirt and dust on the impeller can cause unbalancing and subsequent damages. In order to prevent this danger frequent inspections and cleaning measures have to be carried out depending on the degree of possible deposit.

10.4.2 Motor bearings

The motor bearings are supplied permanently lubricated by the factory; experience has shown that the grease needs to be changed only after several years only under normal operating conditions.

In the case of bearing noise please contact Nicotra Gebhardt-Service for a check and a possible change of defective bearings.

10.4.3 Periods of stand still

During longer periods of standstill the fan must from time to time be put into operation for a short while. This is to avoid bearing damages due to statically mechanical load and ingress of humidity.

After longer periods of storage, the fan and motor bearings have to be checked prior to installation.

CAUTION

If the condition of the fan does not allow modified repair measures it must be put out of commission and be replaced immediately if required.

11. Faults

If any faults occur during operation which cannot be repaired by maintenance personnel please contact the service department at Nicotra Gebhardt GmbH.



Risk of explosion caused by improper operating states!

- ▶ Switch the fan off immediately if permissible limits are exceeded and in the event of irregularities or faults.

12. Service, Spare Parts and Accessories

Nicotra Gebhardt GmbH
Gebhardtstraße 19–25
74638 Waldenburg
Germany

Fon: +49 (0) 7942 101 0
Fax: +49 (0) 7942 101 170
Mail: info@nicotra-gebhardt.com
Web: www.nicotra-gebhardt.com

12.1. Ordering Spare Parts

- ▶ Use only genuine spare parts supplied by Nicotra Gebhardt GmbH as featured in the list of spare parts.

The use of spare parts supplied by other manufacturers may compromise the safety of the equipment. Nicotra Gebhardt GmbH shall not accept any liability or provide any warranty cover in respect of primary or secondary damage arising as a consequence of using spare parts supplied by other manufacturers.

Spare parts can be ordered online at -- www.nicotra-gebhardt.com/Partshop

12.2. Accessories

Nicotra Gebhardt GmbH has a wide range of accessories for the economical and efficient use of its fans.

Accessories are optional and always need to be ordered separately.

Spare parts should be selected on the basis of the technical specifications or via our electronic selection program. Accessories are supplied with separate operating or installation instructions unless their installation or uses are self-explanatory.

13. Annex

13.1 Further Documentation Supplied by Nicotra Gebhardt GmbH

Tabelle 13 1: Further documentation

Type of Documentation	File Location
Maintenance and inspection recommendations	Internet
EC-Declaration of Conformity 2014/34/EU (ATEX)	Annex
EC-Declaration of Incorporation	Annex

EU Declaration of Conformity to EU Council Directive 2014/34/EU (ATEX)

The manufacturer: **Nicotra Gebhardt GmbH,**
Gebhardtstraße 19-25, 74638 Waldenburg, Germany

herewith declares, that the machinery designated below, on the basis of its design and construction in the form brought onto the market by us is in accordance with the relevant safety and health requirements of the EU Council Directive as mentioned below.

If any alterations are made to the machinery without prior consultations with us this shall render the declaration invalid.

Designation: **Plug fans without scroll of categories 2G for conveying explosive atmosphere**

Machine type: **RLM 55-....-2G; RLM 56-....-2G;
RLM E6-....-.Y-..-.; RLM E3-....-.Y-..-.; RLM G6-....-.Y-..-.**

Category: **II2G Ex h IIB T4 Gb ; II2G Ex h IIB+H2 T4 Gb**

Year of Production/Type: **See type plate**

Relevant EC Council Directive: **EU Directive 2014/34/EU (ATEX)**

Statement of deposition: **EX9 12 10 78300 006 (RLM E6 + RLM G6)
EX9 14 11 78300 007 (RLM E3)
EX9 11 09 78300 003 (RLM 55/56)**

Name of Notified Body: **TÜV SÜD Product Service; Certification Body; Ridlerstraße 65;
80339 Munich; Germany**

Applied harmonized standards ¹⁾, in particular: **EN 1127-1, EN 14986, EN 60079-0, EN ISO 80079-36, EN ISO 80079-37**

It is the responsibility of the manufacturer or contractor to ensure that conformity to these standards is observed when installing the fan in a machine or system.

The manufacturer is solely responsible for issuing this declaration of conformity.

Waldenburg, 20.01.2019

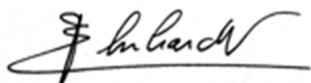

i.V. T. Ehrhardt
Head of production



i.V. Dr. J. Anschütz
Research and Development Director

¹⁾ The complete listing of applied standards and technical specifications please see manufacturer's documentation.

EC-Declaration of Incorporation

The manufacturer: **Nicotra Gebhardt GmbH**,
Gebhardtstraße 19-25, 74638 Waldenburg, Germany

herewith declares, that the following product:

Product designation: **Plug fans without scroll of categories 2G for conveying explosive atmosphere**

Type nomination: **RLM 55-....-2G; RLM 56-....-2G;
RLM E6-.... -.Y-..-.; RLM E3-.... -.Y-..-.; RLM G6-.... -.Y-..-.**

Serial n°: **see type plate**

Year of manufacture: **see type plate**

qualifies as a partly completed machine, according to Article 2, clause “g” and complies with the following basic requirements of the **Machine Directive (2006/42/EC): Annex I, Article 1.1.2; 1.3.7.**

The partly completed machine may be put into operation only if it has been stated that the machine into which the uncompleted machine has to be incorporated complies with the requirements of the Machine Directive (2006/42/EC).

The following harmonised standards¹⁾ have been applied:

DIN EN ISO 12100 Safety of machines – General design principles

DIN EN ISO 13857 Safety of machines – Safety distances to hazardous areas

Applied, national standards and technical specifications²⁾ particularly:

VDMA 24167: Fans - Safety requirements

The manufacturer is committed to providing the special documents, to Annex VII, Part B for partly completed machines to any state authority on request by mail / e-mail.

Waldenburg, 20.01.2019

Representative for the documentation: Michael Hampel

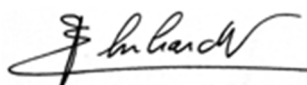

i.V. T. Ehrhardt
Head of production



i.V. Dr. J. Anschütz
Research and Development Director

¹⁾ The complete listing of applied standards and technical specifications see manufacturer's documentation.

²⁾ If no corresponding harmonized standards are available yet

NICOTRA || **Gebhardt**
fan|tastic solutions

Nicotra Gebhardt GmbH
Gebhardtstraße 19-25
74638 Waldenburg
Germany

Fon: +49 (0)7942 101 0
Fax: +49 (0)7942 101 170
Mail: info@nicotra-gebhardt.com

Web: www.nicotra-gebhardt.com

A.3 Hoval

Installation of compound
plate heat exchangers

Hoval

**Caution**

Risk of injury from incorrect handling. Transport, assembly and installation work may only be performed by specialists!

1 Preparation

- Check that the delivery is complete:
 - 4 exchanger blocks
 - 1 cartridge of sealing compound
 - Auxiliary materials for installation (rivets, self-cutting screws)
 - 6 angle brackets (depending on the width of the exchanger)



Notice: Angle brackets are not installed in exchangers with a width of up to 1500 mm.

- Option: Control damper (one-piece for size 140/170, two-piece for size 200/240)
- Required tools:
 - Hoisting equipment to lift the components
 - Cartridge gun
 - Rivet gun
 - Drill
 - Power screwdriver
- Identify the correct position of exchanger blocks 1 to 4:
 - Each side wall has a flattened corner. These corners make up the outer edges of the exchanger once assembled.
 - For exchangers with a bypass (option): make sure that the bypass is aligned correctly.

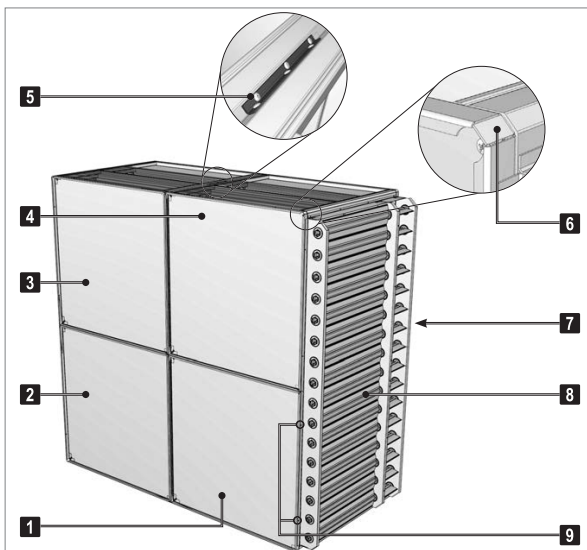

- 1 Exchanger blocks nos. 1 – 4
- 2
- 3
- 4
- 5 Angle bracket
- 6 Flattened corner of the side wall
- 7 Side bypass (option)
- 8 Control damper (option)
- 9 Positioning holes for the control damper (on all sides)

Fig. 1: Compound plate heat exchanger (shown here with a side bypass and control damper)

Art. No. 4 212 499-en-00 / Page 1

Installation of compound plate heat exchangers

Hoval

2 Installation

2.1 Installing the exchanger blocks

- Prepare block no. 1 (flattened corner at the bottom).
- Apply the sealing compound in the sealing groove that runs around the block.
- Attach block no. 2.
- Use rivets to connect the flanges of the side walls to one another.
- Attach angle brackets 1-2 (inside and outside):
 - Place the bracket onto the corner sections in the middle of the exchanger.
 - Drill holes and insert rivets.
- Rotate blocks 1 and 2.
- Apply the sealing compound in the sealing groove that runs around block no. 2.
- Attach block no. 3.
- Use rivets to connect the flanges of the side walls to one another.
- Attach angle brackets 2-3 (inside and outside).
- Apply the sealing compound in the sealing grooves that run around blocks 1 and 3.
- Attach block no. 4.
- Use rivets to connect angle brackets 3-4 and 4-1 to the corner sections.

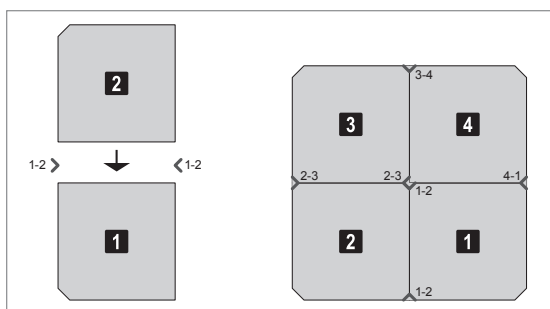

Fgi. 2: Installation sequence and position of the angle brackets



Fgi. 4: Rivet the side wall flanges to one another



Fgi. 3: Apply sealing compound



Fgi. 5: Rivet on the angle brackets

Installation of compound plate heat exchangers

Hoval

2.2 Installing the control damper (option)

- Identify the correct position for the damper:
 - Place it on the open side of the bypass.
 - For exchangers with a side bypass: pay attention to the installation position of the exchanger.
- Rotate the exchanger so that it is positioned correctly (damper at the top).
- Attach the damper to the exchanger.
- Rivet the damper in the positioning holes of the side wall flange on both sides.
- Attach the damper to the corner sections of the exchanger using self-cutting screws.

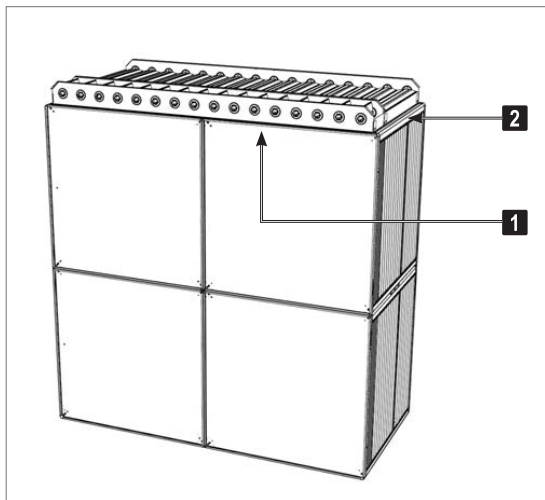

1 Side wall flange with positioning holes

2 Corner section of the exchanger

Fgi. 6: Installation of the control damper

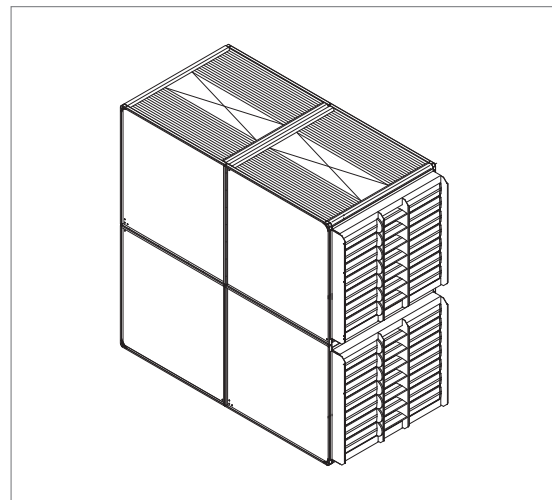

Fgi. 7: For plate heat exchangers in size 200/240, the control damper is in two pieces (shown here with a bypass in the middle)

A.4 GEA pocket filter

Name	Data
Designation	Pocket filter
Type	Multisack G85 EX
Number	
Type of manual	Operating manual
Manufacturer	GEA



Proper use of the GEA explosion protected bag filters Multisack G85 EX stipulates compliance with the current operation manual. This manual must always be available at the site where the unit is in operation. Every person working on or with the GEA explosion protected bag filters of series Multisack G85 EX must read and understand this operation manual fully.

1. Technical Data

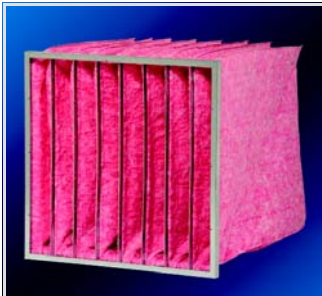

Type/designation	Dimensions W x H x D [mm]	Number of bags [quantity]	Filter surface [m ²]	Max. rated air flow rate [m ³ /h]
Bag filter G85 EX	592 x 592 x 600	8	2.6	4,250

Filter class	Norm	Initial pressure difference [Pa]	Max. end pres- sure difference [Pa]	Air flow velocity [m ³ /h]	Order number
F7	EN 779	91.7	450	3,400	10 42 646

Specifications:

Frame material: Galvanized metal sheet
 Filter medium: Micro glass fibre
 Max. operating temperature [°C]: -40 to +80
 Max. relative humidity [%]: 90
 Filter with grounding element

Notes:

Identification of explosion protection: II 2 GD IIB T6
 (-40°C to +80)
 Explosion protection conformity: RL 94/9/EG
 Unit category 2, group II RL 94/9/EG
 Application in zones 1, 2, 21, 22 RL 999/92/EG

2. Safety Instructions

Proper use

GEA explosion protected bag air filters of series Multisack G85 EX of the equipment category 2, group II in accordance with the EU directive 94/9/EG on explosion risk in areas with an explosive atmosphere or EN 13463-1:2001 are exclusively used to filter solid matter particles and dust of any kind and size out of air in air handling systems. Filtered air can be charged with foreign matter and the relevant surroundings can be classified as an explosion risk areas in accordance with 1999/92/EG directive on explosion protection. GEA explosion protected bag air filters of series Multisack G85 EX are exclusively suitable in explosion risk areas in zones 1, 2, 21 and 22 in accordance with 1999/92/EG directive on explosion protection.

Further process instructions and regulations on explosion risk prevention in terms of 1999/92/EG directive as well as other usually applied directives on using, handling, maintenance and recycling of air filters for air handling units SWKI 2003 as well as VDI 6022 must be taken into account.

Label

The supplied label must be attached on the external side of a service door of an air handling unit. The label must be clearly visible and accessible.



GEA explosion protected bag filters of series Multisack G85 EX are installed in air handling units that are classified as explosion risk areas according to 1999/92/EG and 94/9/EG directives on explosion risk protection. The Multisack G85 is not suitable for explosion risk areas where hybrid mixtures lead to explosion hazards.



Possible electrostatic charges of the GEA explosion risk protected bag filters of the series Multisack G85 EX are continuously diverted without special structural changes or technical measures if the following conditions are met:

- The air filter frame must always have an electrically conductive connection with the relevant filter retainer. For this purpose - an additionally supplied grounding set must be mounted and secured. This grounding set must be mounted in such a way that self-removal or accidental removal because external influence is prevented (⇒ refer to section „3. Installation“).
- The filter retainer as well as all electrically conductive components of an air handling unit must be grounded. This can be achieved by using conductive contact surfaces between components (direct contact) or an electrical conductor (e.g. grounding cable).

Air flow velocity and rated air flow rate

Air flow velocity through filter may not exceed 10 m/s and rated air flow rate specified in the technical data may not be exceeded under any circumstances.

In case of proper use of the GEA explosion protected bag filters at specified rated air flow rate the air flow velocity through filter medium will not exceed 0,5 m/s even if the filter has reached the intended operating life or compulsory maximum end pressure difference. The standard value for dimensioning is specific maximum air flow rate 0,3 m³/s per m² of filter surface. It must always be possible to check the maximum rated flow rate (⇒ refer to section „1. Technical Data“) of the unit by using check and monitoring devices (e.g. differential pressure monitor or flow measuring devices).



3. Installation

Pre-installation work

- Make sure that the planned installation location is suitable for the operation of the GEA explosion protected bag filter. This comprises the following:
 - The classification of the installation site as a hazard zone according to RL 1999/92/EG
 - Availability of a company internal document on explosion risk protection in accordance with RL1999/92/EG and the occupational safety codes and regulations.
- Remove the GEA explosion protected bag filter Multisack G85 EX from its packaging outside the explosion risk zone:
 - Handle the bag filter with care and do not damage the filter medium
 - Inspect the bag filter for any external damage and check if the grounding set is complete (operation manual and explosion protection label); if the filter is damaged or the grounding set is missing - the filter may not be mounted.

Installation

- Loosen the old grounding set from the unit.
- Remove the old bag filter including the grounding set.
- Carry out all necessary cleaning of the unit.
- Insert the new GEA explosion protected bag filter Multisack G85 EX in the unit and secure the filter using filter retainers.
- Screw the grounding electric cable with a ring tongue lug to grounded unit component together (e.g. filter retainer, slide in frame, monoblock etc.) in such a way that self or accidental removal without a tool is impossible.
- ✓ An electrically conducting connection between air filter frame and unit component must be ensured!
- Check the ring tongue lug for secure seat.
- Check electric resistance between filter frame and unit component using an ohmmeter – no matter where the measuring point is - electric resistance may not exceed 1 M Ω (Mega-Ohm).

4. Operating Life/Durability of the GEA Explosion Protected Bag Filter Multisack G85 EX

The characteristics and features of the GEA explosion protected bag filter Multisack G85 EX are the same as with conventional bag filters of the same type and same configuration.

- Replace the bag filter when the maximum allowed end pressure difference is reached. It can be assumed that the maximum allowed end pressure difference amounts to a standard value with initial pressure difference plus 100 Pascal of pressure drop increase. Refer to section "1. Technical Data" for the effective maximum allowed end pressure difference.
- Moreover, consider the recommendations of the hygiene directive SWKI 2003-5 and VDI 6022 in terms of the maximum service life.

A.5 EMW compact filter

Name	Data
Designation	Compact filter
Type	ATEX filter
Number	
Type of manual	Instruction manual
Manufacturer	EMW filtertechnik

Instructions for ATEX Air Filters

In conformance with ATEX Directive 94/9/EC Appendix II

Before starting with installation, **read these instructions completely** and follow them exactly. Not following the instructions can result in serious injuries and/or damages. Before carrying out installation, check to be sure that the filter selected is suitable for your intended application.

In accordance with legal regulations the installation of the filter may be carried out by qualified installation technicians only.

1) START-UP INSTRUCTIONS

1.1) APPLICATION

ATEX air filters are used to filter dust-laden gaseous substances in potentially explosive atmospheres.

1.2) USE AND MARKING OF THE PRODUCT

(in conformance with ATEX Directive 94/9/EC)

Intended use of the product: filtration of gaseous substances with dust content.

The filter can be used in potentially explosive atmospheres as follows:

- Gas:**
- zones 0, 1 or 2 (models with **fabric handles** are **not suitable** for usage in **zone 0**)
 - gas groups IIA, IIB or IIC (models with **fabric handles** are **not suitable** for usage in **gas group IIC**)
- Dust:**
- zone 20, 21 or 22 (models with **fabric handles** are **not suitable** for usage in **zone 20**)
 - conductive dusts must be excluded from these applications

Marking:

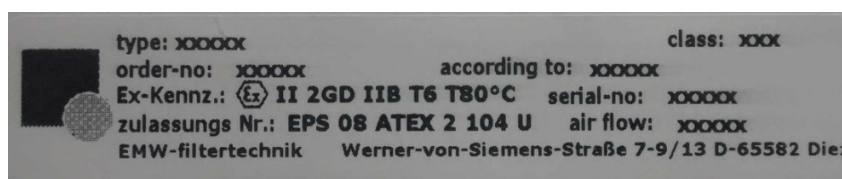
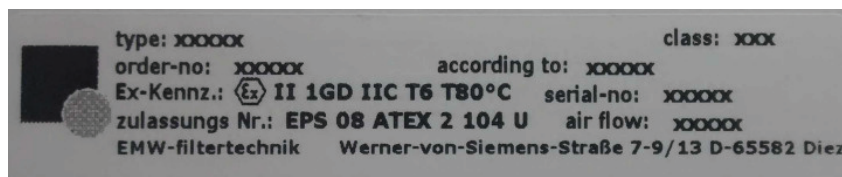

1.3) STANDARDS

When installed and used in accordance with operating instructions, this product conforms to the following standards: EN 13463-1 (2009)

1.4) MECHANICAL PROPERTIES

- Used for:** Final filtration or pre-filtration of dust-laden, potentially explosive atmospheres, filter classes F6/M6 up to U15
- Storage temperature:** -10 to +40°C
- Operating temperature:** -40 to +80°C
- Relative humidity:** 5% to 95%, without condensation

Instructions for ATEX Air Filters Rev. 7, 28.04.2015

Seite 1 von 2

1.5) INSTALLATION

The filter unit must be mandatory connected with **at least one** suitable potential equalisation device and for usage in ATEX zones 0 or 20 with **at least two** suitable, independently working and not self-detachable **potential equalisation devices**. All conductive components and all parts, through which discharge can occur, must be interconnected and grounded.

Some filters are supplied with **two separately added potential equalisation devices** consisting of:

- 2 pz. grounding cable with eyelets at the cable ends
- 2 pz. screw for fixing the potential equalization device on the filter
- 2 pz. star washer externally toothed to be fit between eyelet and filter frame

Please attach the required number of potential equalisation devices to **suitable attachment points** on the filter frame. The screw is inserted through the eyelet and the washer and screwed at an attachment point on the filter frame as shown below.

It is possible to renounce on the installation of the added potential equalisation devices **only** if a safe potential compensation is guaranteed at all time by a suitable filter fastening device of the air-handling system. If in doubt, this is to check by a qualified person by using an appropriate measuring device (eg. multimeter).

Maximum torque of the screw: 0.5 Nm

Possible attachment points

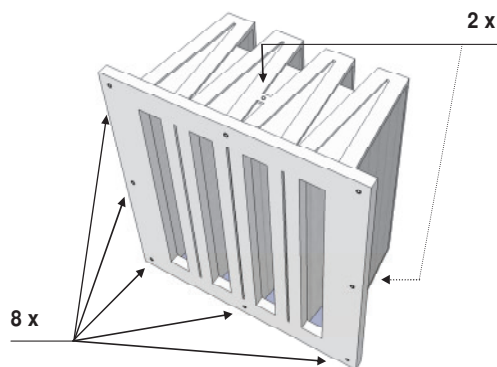

Mounting of the potential equalisation devices

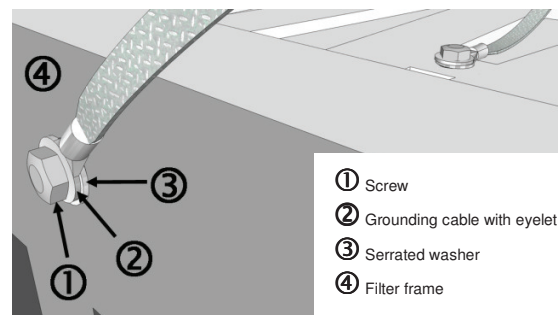

Proper mounting of suitable potential equalisation devices and **periodic monitoring** of the potential compensation must be ensured **by the user** of the filter unit.

The ambient temperature range differs from the standard ambient temperature range and is $-40^{\circ}\text{C} \leq T_a \leq +80^{\circ}\text{C}$

1.5.1) MOUNTING AND ASSEMBLY

The filter element can be operated in either vertical or horizontal position.

Please note:

- vertical position of filter element: the throughput openings should be positioned vertically
- horizontal position of filter element: the position of the throughput openings is irrelevant

2) MAINTENANCE

Observe the following precautionary measures when carrying out maintenance:

When removing or changing the filter, the unit must be **FREE OF VOLTAGE**.

Instructions for ATEX Air Filters Rev. 7, 28.04.2015

Seite 2 von 2

A.6 Briem MD201 MB E 4301 Atex differential pressure gauge

Name	Data
Designation	Briem MD 201 MB E 4301 Atex
Type	Differential pressure gauge
Number	
Type of manual	Technical data sheet
Manufacturer	

MD201 MB E 4301 Atex

Differenzdruckmessgerät mit Analogan- zeige und einem elektrischen Schaltkontakt und Atex Zulassung



Differenzdruckmessgeräte mit Analoganzeige und stufenlos einstellbarem Schaltkontakt im Edelstahl-Gehäuse werden vorwiegend in der Pharmazie, Chemie und Medizintechnik verwendet.

Das MAGNEHELIC-Messgerät arbeitet rein mechanisch und zeigt den Differenzdruck unabhängig vom eingebauten Differenzdruckschalter an. Die Schaltkontakte sind vergoldet und können potentialfrei unter Ex-Schutz (EEx-ia) abgefragt werden.

Die Zündschutzart Eigensicherheit bezieht sich immer auf einen eigensicheren Stromkreis, der eigensichere oder zugehörige Betriebsmittel und die Verbindungskabel einschließt. So können weder Funken noch thermische Effekte zur Zündung einer explosionsfähigen Atmosphäre führen.

Das Differenzdruckmessgerät darf nur an einem eigensicheren Stromkreis angeschlossen werden. Eine Reparatur darf ausschließlich nur durch den Hersteller erfolgen. Das Gerät arbeitet wartungsfrei.



Optional: Zu dem Differenzdruckmessgerät MD201 MB E 4301-Atex sind auch Trennschaltverstärker/Messumformer-speisegeräte erhältlich, deren Einsatz je nach Ex-Bereich erforderlich ist.

Gehäusemontage Optional auch quer möglich – Anschlüsse dann seitlich oder unten.

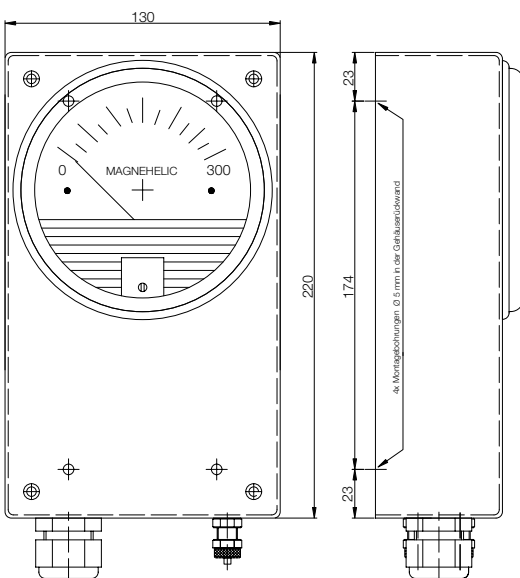
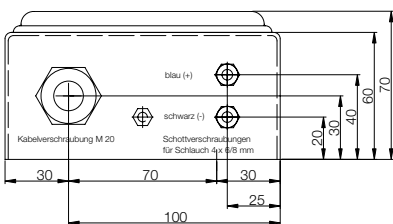

Technische Daten

Medien	Luft oder nicht aggressive Gase
Messgenauigkeit	≤ ±2 %
Schaltfehler	≤ ±3 %
Maximaler Betriebsdruck	5 kPa
Druckanschlüsse	zwei Druckanschlussstutzen für Schlauch 4 × 6/8 mm blau für höheren Druck (+) schwarz für geringeren Druck (-)
Unterdruckgrenze	max. -5 kPa
Bezugsdruck (absolut)	~1 bar (Atmosphäre)
Zulässige Umgebungstemperatur	-20 bis +50 °C
Mikroschalter	einpoliger Umschalter
Schaltleistung	50 mA, 15 VDC, 100 mW
EG-Baumusterprüfbescheinigungs-Nr.	ZELM 04 ATEX 0224X
Schutzklasse	II2G Ex ia IIC T6 nach EN 60079-0:2009/ EN 60079-11:2007
CE-Zulassung	94/9/EG (Atex)
Schutzart	IP 54
Elektroanschluss	Schraubklemmen mit M 20 Kabelverschraubung und Zugentlastung
Gewicht	~2,2 kg

Anmerkung:

Zusätzlich zu dieser Betriebsanleitung ist die EG-Baumusterprüfbescheinigung ZELM 04 ATEX 0224X zu beachten.

Schaltschema MD 201 MB - E4301-Atex

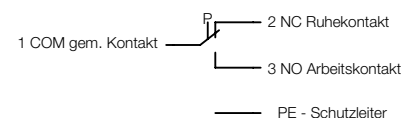

Typenübersicht

Modell	Messbereich	Einstellbereich	Rückschaltdifferenz
MD201- 3MB-E 4301-Atex	0-300 Pa	20-300 Pa	10 Pa
MD201- 5MB-E 4301-Atex	0-500 Pa	50-500 Pa	20 Pa
MD201-10MB-E 4301-Atex	0-1.0 kPa	0.1-1.0 kPa	40 Pa
MD201-20MB-E 4301-Atex	0-2.0 kPa	0.5-2.0 kPa	100 Pa

Mess- und Einstellbereiche können miteinander kombiniert werden bzw. es können auch Differenzdruckmessgeräte vom Typ M2000 oder M2300 bis zu einem Messbereich von 5.0 kPa mit o.g. Einstellbereichen kombiniert werden. Mess- und Einstellbereiche sind jeweils auf dem Typenschild eingraviert.

Briem

Steuerungstechnik GmbH
Lauterstraße 23
D-72622 Nürtingen
Tel. +49 (0)70 22-60 92-0
Fax +49 (0)70 22-60 92-60
info@briem.de
www.briem.de

A.7 Actuators

Name	Data
Designation	Actuator
Type	MAX actuator, sizes M and S
Number	
Type of manual	Instruction manual
Manufacturer	Schischek



ExMax ¼ turn actuators – size M

Electrical, explosion proof rotary actuators

On-off / 3-pos. control mode, 24...240 VAC/DC, 95° angle of rotation incl. 5° pretension

50 / 75 – 100 – 150 Nm without and 30 – 50 – 60 Nm with safety operation (spring return)

ATEX tested in acc. with directive 2014/34/EU for zone 1, 2, 21, 22

ExMax - ...
ExMax - ... - F
ExMax - ... - S
ExMax - ... - SF
ExMax - ... - CTM

Subject to change!

Compact. Easy installation. Universal. Cost effective. Safe.

Type	Torque	Supply	Motor running time	Spring return	Control mode	Feedback	Wiring diagram
ExMax- 50.75	50 / 75 Nm	24...240 VAC/DC	40 / 60 / 90 / 120 / 150 s/90°	–	On-off, 3-pos.	–	SB 1.0
ExMax- 100	100 Nm	24...240 VAC/DC	40 / 60 / 90 / 120 / 150 s/90°	–	On-off, 3-pos.	–	SB 1.0
ExMax- 150	150 Nm	24...240 VAC/DC	40 / 60 / 90 / 120 s/90°	–	On-off, 3-pos.	–	SB 1.0
ExMax- 30 - F	30 Nm	24...240 VAC/DC	40 / 60 / 90 / 120 / 150 s/90°	~ 20 s/90°	On-off, 3-pos.	–	SB 2.2 + 2.3
ExMax- 50 - F	50 Nm	24...240 VAC/DC	40 / 60 / 90 / 120 / 150 s/90°	~ 20 s/90°	On-off, 3-pos.	–	SB 2.2 + 2.3
ExMax- 60 - F	60 Nm	24...240 VAC/DC	40 / 60 / 90 / 120 s/90°	~ 20 s/90°	On-off, 3-pos.	–	SB 2.2 + 2.3
ExMax- ... - S/SF	Types as above with 2 integral, potential free auxiliary switches, 5° and 85° angle of rotation					2 × limit switches	SB 3.0
ExMax- ... - CTM	Types as above with aluminium housing and seawater resistant coating (cable glands brass nickel-plated)						

Product views and applications

Safety damper



Ball valve



Throttle valve



Description

The ExMax actuators are a revolution for safety, control and shut-off dampers, ball valves, throttle valves and other motorized applications for HVAC systems in chemical, pharmaceutical, industrial and offshore/onshore plants, for use in Ex-areas zone 1, 2 (gas) and zone 21, 22 (dust). Highest protection class (ATEX) and IP66 protection, small dimensions, only 9,5 kg weight, universal functions and technical data, an integrated heater and an optional stainless steel housing guarantee safe operation even under difficult environmental conditions. High quality brushless motors guarantee long life.

All actuators are programmable and adjustable on site. Special tools or equipment are not required. Motor running times and torques are selectable or adjustable on site. The integrated universal power supply is self adaptable to input voltages in the range of 24...240 VAC/DC. The actuators are 100 % overload protected.

...Max...F actuators are equipped with spring return fail safe function. Standard shaft connection is a double square direct coupling with 16 × 16 mm.

Different accessories are available to adapt auxiliary switches, terminal boxes or adaptations for ball valves and throttle valves and other armatures.

Highlights

- ▶ For all type of gas, mists, vapours and dust for use in zone 1, 2, 21 and 22
- ▶ Universal supply unit from 24...240 VAC/DC
- ▶ Different motor running times 40–60–90–120–150 s/90°, adjustable on site
- ▶ Spring return running time ~ 20 s/90°
- ▶ On-off and 3-pos. control with or without spring return function
- ▶ 30–50–60–75–100–150 Nm actuators in the same housing size
- ▶ 100 % overload protected
- ▶ Compact design and small dimension (L × W × H = 288 × 149 × 116 mm)
- ▶ Direct coupling to the damper shaft with double square connection 16 × 16 mm
- ▶ 95° angle of rotation inclusive 5° pretension
- ▶ Robust aluminium housing (optional with seawater resistant coating)
- ▶ IP66 protection
- ▶ Simple manual override included + preparation for comfortable manual override
- ▶ Gear made of stainless steel and sinter metal
- ▶ Weight only ~ 9,5 kg
- ▶ Integral heater for ambient temperatures down to –40 °C
- ▶ Integral safety temperature sensor
- ▶ Integral equipment for manual adjustment (push button, lamp, switch)
- ▶ Preparation for adaptable and adjustable auxiliary switches type ...Switch
- ▶ Wide range of accessories



ExMax-...

ExMax-...-F

ExMax-...-S

ExMax-...-SF

SCHISCHEK
EXPLOSIONPROOF

Special option

... -CTM

Technical data	ExMax- 50.75	ExMax- 100	ExMax- 150	ExMax- 30 -F	ExMax- 50 -F	ExMax- 60 -F
Torque motor (min.)	50 / 75 Nm selectable	100 Nm	150 Nm	30 Nm	50 Nm	60 Nm
Torque spring (F)	–	–	–	min. 30 Nm	min. 50 Nm	min. 60 Nm
Dimension of external torque	Above mentioned torques are min. torques in blocked position, external torque should be max. 80 % of max. actuator torque but min. 10 Nm					
Supply voltage / frequency	24...240 VAC/DC, ± 10 %, self adaptable, frequency 50...60 Hz ± 20 %					
Power consumption	max. starting currents see ① Extra information (in acc. with voltage, $I_{start} \gg I_{rated}$), approx. 5 W holding power, approx. 16 W for heater					
Protection class	Class I (grounded)					
Angle of rotation and indication	95° incl. ~ 5° pretension, mechanical value indication					
Working direction	Selectable by left/right mounting to the damper/valve shaft					
Motor running times [s/90°]	40/60/90/120/150	40/60/90/120/150	40/60/90/120	40/60/90/120/150	40/60/90/120/150	40/60/90/120
Motor	Brushless DC motor					
Spring return (F)	–	–	–	spring return in the event of loss of power		
Spring return running time (F)	–	–	–	spring return in ~ 20 s/90°		
Safety operation	min. 10,000 in acc. with construction of damper and ambient					
Response time spring return	up to 1 sec. after power failure					
Control mode	On-off and 3-pos. in acc. with wiring, selectable on site					
Axle of the actuator	Double square 16 × 16 mm, direct coupling, 100 % overload protected					
Electrical connection	Cable ~ 1 m, wire cross section 0.5 mm ² , equipotential bonding 4 mm ² . Connections in hazardous areas require an Ex-e terminal box!					
Diameter of cable	~ Ø 7.1 mm	~ Ø 7.1 mm	~ Ø 7.1 mm	~ Ø 7.4 mm	~ Ø 7.4 mm	~ Ø 7.4 mm
Cable gland	M16 × 1.5 mm					
Manual override	Use delivered socket wrench, max. 4 Nm					
Integral heater	Integral, controlled heater for ambient temperature down to -40 °C					
Housing material	Aluminium die-cast housing, coated. Optional with seawater resistant coating (...-CTM)					
Dimensions (L × W × H)	288 × 149 × 116 mm, for diagrams see ① Extra information					
Weight	~ 9,5 kg aluminium housing					
Ambients	Storage temperature -40...+70 °C, working temperature -40...+40 °C at T6 and -40...+50 °C at T5					
Humidity	0...90 % rH, non condensing					
Operation mode	100 % of ED are permitted (ED = duty cycle)					
Maintenance	Maintenance free relative to function, maintenance must comply with regional standards, rules and regulations					
Wiring diagrams	SB 1.0	SB 1.0	SB 1.0	SB 2.2 / 2.3	SB 2.2 / 2.3	SB 2.2 / 2.3
Scope of delivery	Actuator with 1 m cable, 4 screws M8 × 140 mm, 4 nuts M8, Allen key for simple manual override					
Parameter at delivery	50 Nm, 90 s/90°	100 Nm, 90 s/90°	150 Nm, 90 s/90°	30 Nm, 90 s/90°	50 Nm, 90 s/90°	60 Nm, 90 s/90°

Approbations

ATEX directive	2014/34/EU
EC type-approved	PTB 04 ATEX 1028 X
IECEX certified	IECEX PTB 07.0057X
Approval for gas	II 2 (1) G Ex d [ia] IIC T6, T5
Approval for dust	II 2 (1) D Ex tD [iaD] A21 IP66 T80, T95°C
CE identification	CE № 0158
EMC directive	2014/30/EU
Low voltage directive	2014/35/EU
Enclosure protection	IP66 in acc. with EN 60529

Special solutions and accessories

...-CTM	Types in aluminium housing with seawater resistant coating, parts nickel-plated
VAMH	Casing in VA for ...Max actuators size M
ExBox-...	Ex-e terminal boxes for zone 1, 2, 21, 22
MKK-M	Mounting bracket for boxes type ...Box-... directly on actuator
ExSwitch	2 external aux. switches, adjustable for zone 1, 2, 21, 22
HV-MK	Comfortable manual override for ...Max actuators size M
AR-16-xx	Reduction part for 16 mm square connection to 14 or 12 mm shafts
Kit-S8	Cable glands nickel-plated
Adaptions	for dampers and valves on request
ExMax-...-S3	Ambient temperature up to +60 °C (T4), 110...240 VAC/DC, 25 % ED

ExMax-M-3P_en
V02 – 20-Apr-2016



ExMax-...

ExMax-...-F

ExMax-...-S

ExMax-...-SF

SCHISCHEK
EXPLOSION PROOF

Special option

... -CTM

Electrical connection

All actuators are equipped with a universal supply unit working at a voltage range from 24...240 VAC/DC. The supply unit is self adjusting to the connected voltage!
The safety operation of the spring return function works if the supply voltage is cut.
For electrical connection inside hazardous areas an Ex-e terminal box, certificated in acc. with ATEX is required (e.g. ExBox).
An over-current protection fuse < 10 A has to be provided by installer.
Note: the initial current is appr. 2 A for 1 second.

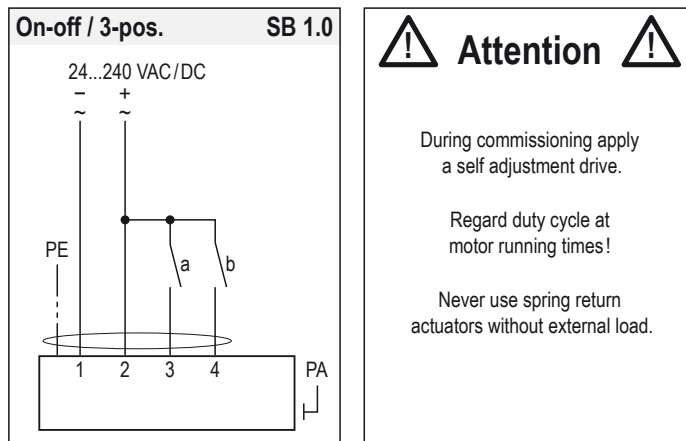
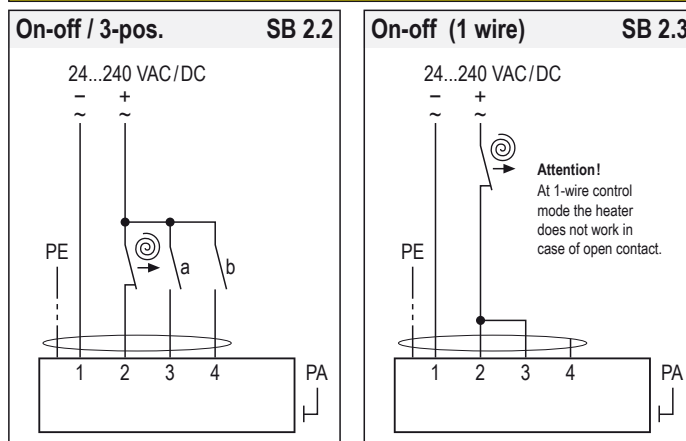
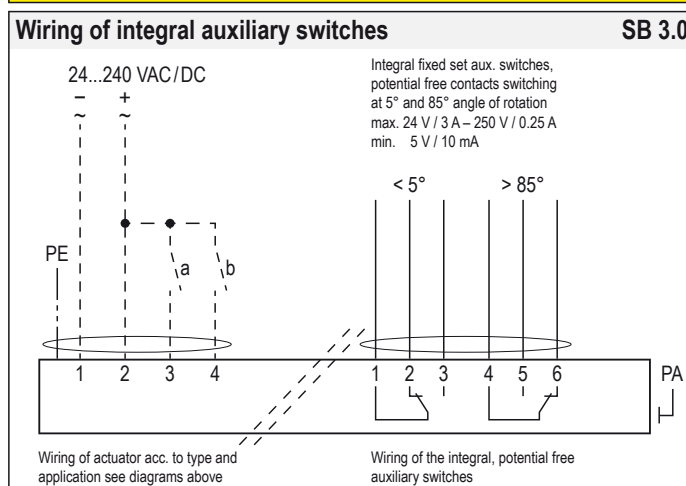
Wiring diagram ExMax- ... (without spring return)**Wiring diagram ExMax- ...-F (with spring return)****Wiring diagram ExMax- ...-S and ...-SF****Parameters, adjustments and failure indication****Switch – Push button – Lamp for adjustment (behind the blanking plug)**

10-position switch (S)
Push button (T)
3-colour LED

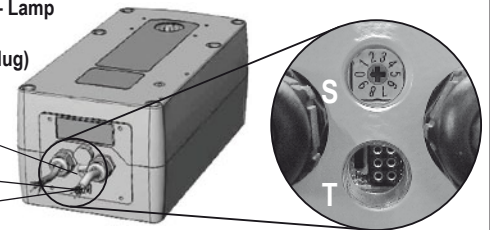
**Parameter selection**

Example:
ExMax-50.75

Requested parameter:
Torque 75 N
Motor running time 90 s/90°

Result:
Switch position **07**

Type	Torques	
ExMax- 50.75	50 N	75 N
ExMax- 100	100 N	
ExMax- 150	150 N	
ExMax- 30 -F	30 N	
ExMax- 50 -F	50 N	
ExMax- 60 -F	60 N	
Running times		Position of switch (S)
40 s/90°	▶ 00	05
60 s/90°	▶ 01	06
90 s/90°	▶ 02	07
120 s/90°	▶ 03	08
150 s/90°	▶ 04	09

Functions, adjustments and parameters**A) Self adjustment of angle of rotation:**

Switch (S) into position 02 (low torque) or 07 (high torque), then push button (T) for minimum 3 seconds. The actuator will drive into both end positions to be adjusted. LED indicates GREEN.

Adjustment time needs approx. 180 sec. (90 sec. "On", 90 sec. "Off"). After that, switch (S) into the position acc. with your required torque and running time.

B) Selection of running time and torque:

Put switch (S) into the correct selected position in acc. to above table. The selected parameter will work at next operation of the actuator. Adjustment can be done even without supply voltage. If supply voltage is available turn switch only if actuator is not running.

C) Additional information for 3-pos. operation:

a closed, b open = direction I a and b closed = motor doesn't work
b closed, a open = direction II a and b opened = motor doesn't work
The rotation direction (I and II) depends on left/right mounting of the actuator to the damper/valve. You can change direction of the motor by changing electrical wiring of terminal 3 and 4.

Installation

Ex area –
zone 1, 2, 21, 22



Safe area



...Max-...-S or -SF (aux. switches)
24 V / 3 A – 250 V / 0.25 A

supply *
24...240 VAC/DC ± 10 %

* electrical wiring see diagrams

- Do not open the cover when circuits are live
- Regard all regional standards, rules and regulations
- Supply cables must be installed in a fixed position and protected against mechanical damage
- For wiring use an explosion proof Ex-e terminal box
- Connect potential earth
- Note ambient temperature
- Avoid temperature transfer from process (e.g. hot gas) to actuator (note max. ambient temperature!)
- Close all openings with min. IP66
- Flameproof enclosure is protected against mechanical damages acc. to EN 60079-ff
- For outdoor installation a protective housing against rain, snow and sun should be applied as well as a constant supply at terminal 1 and 2 for the integral heater
- Actuators are maintenance free, an annual function test is recommended
- Clean only with damp cloth, avoid dust accumulation



ExMax-...

ExMax-...-F

ExMax-...-S

ExMax-...-SF

SCHISCHEK
EXPLOSIONPROOF

Special option

... -CTM

Important information for installation and operation**A. Installation, commissioning, maintenance**

All national and international standards, rules and regulations for hazardous Ex-areas must be complied. Certified apparatus must be installed in accordance with manufacturer instructions. If the equipment is used in a manner not specified by the manufacturer, the safety protection provided by the equipment may be impaired. For electrical installations design, selection and erection, EN/IEC 60079-14 can be used.

For electrical connection an Ex-e terminal box is required (e.g. ExBox-...).

Attention: If the actuator is put out of operation all Ex rules and regulations must be applied. You have to cut the supply voltage before opening the terminal box!

The cables of the actuator must be installed in a fixed position and protected against mechanical and thermal damage. Connect potential earth. Avoid temperature transfer from armature to actuator! Close all openings with min. IP66.

For outdoor installation a protective weather shield against sun, rain and snow should be applied to the actuator as well as a constant supply at terminal 1 and 2 for the integral heater.

Actuators are maintenance free. An annual inspection is recommended. For electrical installations inspection and maintenance, EN/IEC 60079-17 can be used. Ex-actuators must not be opened by the customer.

B. Manual override

Manual override only if supply voltage is cut. Use delivered socket wrench with slow motions, usage can be tight.

Attention: Releasing or letting go the Allen key too fast at manual operating actuators with spring return causes risk of injury!

C. Shaft connection, selection of running time

Actuators are equipped with a direct coupling double square shaft connection of 16 x 16 mm. The housing of the actuator is axially symmetrically built to select Open-close direction of the spring return function by left-right mounting. Using the 10-position switch different motor running times and spring return running times can be selected on site in acc. to the actuator type.

D. 3-position control mode

...Max actuators are in the best way suitable for the 3-pos. operation. To protect such elements as gears and mounting elements against harmful influences like minimum pulse time, ...Max actuators are protected via internal electronics. It ignores impulses < 0.5 s, the cyclic duration must be min. 0.5 s. At changing direction the pause is 1 s.

E. Spring return

Spring return function works only if the supply voltage for terminal 1 or 2 is cut. In the event of an electrical interruption, the spring returns to its end position even if supply voltage is available again during return function. Thereafter operation will continue.

F. Operation at ambient temperatures below -20 °C

All actuators are equipped with a regulated integrated heating device designed for employments down to -40 °C ambient temperature. The heater will be supplied automatically by connecting the constant voltage supply on the clamps 1 and 2.

1. After mounting the actuator must be immediately electrically connected.
2. The heater switches on automatically when actuator reaches internally -20 °C. It heats up the actuator to a proper working temperature, then heater switches off automatically. Actuator will not run during heating process.
3. The adjustment options are only ensured after this heating up period.

G. Excess temperatures

In acc. to the ATEX rules and regulations Ex actuators must be protected against excess temperature. The internal thermostat works as a maximum limiter and, in the event of failure at incorrect temperatures, shuts off the actuator irreversibly. An upstream connected temperature sensor stops the actuator before reaching its max. temperature. This safety feature is reversible, after cooling down the actuator is completely functional again. In this case the failure must be eliminated immediately on site!

H. Synchron mode

Do not connect several actuators to one shaft or link mechanically together.

I. Mechanical protection

The actuator must be operated with an outside load of at least 10 Nm.

After installing the actuator to the damper/armature an automatic alignment has to be accomplished in order to obtain a "gentle" blockade/stop. This function protects the damper/armature by reducing the end position's/blockade speed in order to avoid mechanical overload. The actuator aligns specifically once with 90 s/90° onto each position and recognizes the blockade position in order to reduce the motor performance during operation briefly before reaching the end/blockade position.

J. Intrinsically safe circuits

The actuator itself has a flameproof enclosure. The supply of the push button (adjustment drive), the 10-position switch (adjustment of torque and running time) and the LED indicator is performed intrinsically safe!

K. Loss of voltage

In switch position 00, 01 and 05, 06 (motor running times 40 sec. and 60 sec.) and after interrupted voltage the actuator (types 50.75, 100 and 150 and ...-S) moves in OFF position then the actuators works regarding control signal.

❗ Extra information (see additional data sheet)

Additional technical information, dimensions, installation instruction, illustration and failure indication

Accessory ExSwitch – adaptable Ex-d auxiliary switch

For an end or inclined position indication it is possible to retrofit external, adjustable, explosion proof auxiliary switches type ExSwitch. The switch housing is mounted directly to the actuator and the switches are linked to the actuator's square connector. The switches deliver a potential free output and can be adjusted separately. They are connected by the included cable tail.

Accessory ExBox – adaptable Ex-e terminal box

For electrical connection of ...Max actuators inside the hazardous area an Ex-e terminal box is required. ExBoxes are appropriate terminal boxes and placed at the disposal. To adapt the ...Box directly to the actuator housing a mounting bracket type MKK-M is required.

ExBox- 3P for ...Max-... and ...Max-...-F
ExBox- Y/S for ...Max-...-S and ...-SF with integral auxiliary switches

ExMax ¼ turn actuators – size S

Electrical, explosion proof rotary actuators

On-off / 3-pos. control mode, 24...240 VAC/DC, 95° angle of rotation incl. 5° pretension

5/10 Nm, 15/30 Nm without and 5/10 Nm, 15 Nm with safety operation (spring return)

ATEX tested in acc. with directive 2014/34/EU for zone 1, 2, 21, 22

ExMax - ...
ExMax - ... - F
ExMax - ... - S
ExMax - ... - SF
ExMax - ... - CTS
ExMax - ... - VAS

Subject to change!

Compact. Easy installation. Universal. Cost effective. Safe.

Type	Torque	Supply	Motor running time	Spring return	Control mode	Feedback	Wiring diagram	
ExMax- 5.10	5 / 10 Nm	24...240 VAC/DC	3 / 15 / 30 / 60 / 120 s/90°	–	On-off, 3-pos.	–	SB 1.0	
ExMax-15.30	15 / 30 Nm	24...240 VAC/DC	3 / 15 / 30 / 60 / 120 s/90°	–	On-off, 3-pos.	–	SB 1.0	
ExMax- 5.10 - F	5 / 10 Nm	24...240 VAC/DC	3 / 15 / 30 / 60 / 120 s/90°	3 or 10 s/90°	On-off, 3-pos.	–	SB 2.0 + 2.1	
ExMax- 15 - F	15 Nm	24...240 VAC/DC	3 / 15 / 30 / 60 / 120 s/90°	3 or 10 s/90°	On-off, 3-pos.	–	SB 2.0 + 2.1	
ExMax- ... - S/SF	Types as above with 2 integral, potential free auxiliary switches, 5° and 85° angle of rotation						2 × limit switches	SB 3.0
ExMax- ... - CTS	Types as above with aluminium housing and seawater resistant coating (cable glands brass nickel-plated)							
ExMax- ... - VAS	Types as above with stainless steel housing for aggressive ambient (cable glands brass nickel-plated)							

Product views and applications

Safety damper



Ball valve



Throttle valve



Description

The ExMax actuators are a revolution for safety, control and shut-off dampers, VAV systems, ball valves, throttle valves and other motorized applications for HVAC systems in chemical, pharmaceutical, industrial and offshore/onshore plants, for use in Ex-areas zone 1, 2 (gas) and zone 21, 22 (dust).

Highest protection class (ATEX) and IP66 protection, small dimensions, only 3,5 kg weight, universal functions and technical data, an integrated heater and an optional stainless steel housing guarantee safe operation even under difficult environmental conditions. High quality brushless motors guarantee long life.

All actuators are programmable and adjustable on site. Special tools or equipment are not required. Motor running times and torques as well as spring return times, according to the actuator type, are selectable or adjustable on site. The integrated universal power supply is self adaptable to input voltages in the range of 24...240 VAC/DC. The actuators are 100 % overload protected and self locking.

...Max...F actuators are equipped with spring return fail safe function. Standard shaft connection is a double square direct coupling with 12 × 12 mm.

Different accessories are available to adapt auxiliary switches, terminal boxes or adaptations for ball valves and throttle valves and other armatures.

Highlights

- ▶ For all type of gas, mists, vapours and dust for use in zone 1, 2, 21 and 22
- ▶ Universal supply unit from 24...240 VAC/DC
- ▶ 5 different motor running times 3–15–30–60–120 s/90°, adjustable on site
- ▶ 2 different spring return running times ~ 3–10 s/90°, selectable on site
- ▶ On-off and 3-pos. control with or without spring return function
- ▶ 2 integrated auxiliary switches, switching at 5° and 85° (option ...-S)
- ▶ 5–10–15–30 Nm actuators in the same housing size
- ▶ 100 % overload protected and self locking
- ▶ Compact design and small dimension (L × W × H = 210 × 95 × 80 mm)
- ▶ Direct coupling to the damper shaft with double square connection 12 × 12 mm
- ▶ 95° angle of rotation inclusive 5° pretension
- ▶ Robust aluminium housing (optional with seawater resistant coating) or in stainless steel
- ▶ IP66 protection
- ▶ Simple manual override included + preparation for comfortable manual override
- ▶ Gear made of stainless steel and sinter metal
- ▶ Weight only ~ 3,5 kg
- ▶ Integral heater for ambient temperatures down to -40 °C
- ▶ Integral safety temperature sensor
- ▶ Integral equipment for manual adjustment (push button, lamp, switch)
- ▶ Preparation for adaptable and adjustable auxiliary switches type ...Switch



ExMax-...

ExMax-...-F

ExMax-...-S

ExMax-...-SF

SCHISCHEK
EXPLOSIONPROOF

Special options

... -CTS

... -VAS

Technical data	ExMax- 5.10	ExMax- 15.30	ExMax- 5.10 -F	ExMax- 15 -F
Torque motor (min.)	5 / 10 Nm selectable on site	15 / 30 Nm selectable on site	5 / 10 Nm selectable on site	15 Nm
Torque spring (F)	–	–	min. 10 Nm	min. 15 Nm
Dimension of external torque	Above mentioned torques are min. torques in blocked position, external torque should be max. 80 % of max. actuator torque but min. 3 Nm			
Supply voltage / frequency	24...240 VAC/DC, ± 10 %, self adaptable, frequency 50...60 Hz ± 20 %			
Power consumption	max. starting currents see ⓘ Extra information (in acc. with voltage, $I_{start} \gg I_{rated}$), approx. 5 W holding power, approx. 16 W for heater			
Protection class	Class I (grounded)			
Angle of rotation and indication	95° incl. ~ 5° pretension, mechanical value indication			
Working direction	Selectable by left/right mounting to the damper/valve shaft			
Motor running times	3 / 15 / 30 / 60 / 120 s/90° selectable on site			
3 sec. mode – motor	In acc. with the supply voltage and external torque 3 to 4 s/90° angle of rotation			
Motor	Brushless DC motor			
Spring return (F)	–	–	spring return in the event of loss of power	
Spring return running time (F)	–	–	spring return in ~ 3 or 10 s/90°, selectable on site	
3 sec. mode – spring return	–	–	in acc. with external torque ~ 3 to 4 s/90° angle of rotation	
Safety operation at 10 sec. (F)	–	–	min. 10,000 in acc. with construction of damper and ambient	
at 3 sec. (F)	–	–	min. 1,000 in acc. with construction of damper and ambient	
Response time spring return	up to 1 sec. after power failure			
Control mode	On-off and 3-pos. in acc. with wiring, selectable on site			
Axle of the actuator	Double square 12 × 12 mm, direct coupling, 100 % overload protected and self locking up to 15 Nm			
Electrical connection	Cable ~ 1 m, wire cross section 0.5 mm ² , equipotential bonding 4 mm ² . Connections in hazardous areas require an Ex-e terminal box!			
Diameter of cable	~ Ø 7.1 mm	~ Ø 7.1 mm	~ Ø 7.4 mm	~ Ø 7.4 mm
Cable gland	2 cable glands in the versions ...-S and ...-SF (~ Ø ... + 7.4 mm)			
Manual override	M16 × 1.5 mm			
Integral heater	Use delivered socket wrench, max. 4 Nm			
Housing material	Integral, controlled heater for ambient temperature down to -40 °C			
Dimensions (L × W × H)	Aluminium die-cast housing, coated. Optional with seawater resistant coating (...-CTS) or stainless steel housing, № 1.4581 / UNS-J92900 / similar AISI 316Nb (...-VAS)			
Weight	210 × 95 × 80 mm, for diagrams see ⓘ Extra information			
Ambients	~ 3,5 kg aluminium housing, stainless steel ~ 7 kg			
Humidity	Storage temperature -40...+70 °C, working temperature -40...+40 °C at T6 resp. -40...+50 °C at T5			
Operating 3 sec. motor run time	0...90 % rH, non condensing			
≥ 15 sec. motor run time	In 3 s mode the motor will work only after 1 minute of voltage supply. While open/close operation (open voltage supply and shut it down) motor works only with speed of 15 s/90°			
Maintenance	At 15 / 30 / 60 / 120 s 100 % of ED is permitted (ED = duty cycle)			
Wiring diagrams	Maintenance free relative to function, maintenance must comply with regional standards, rules and regulations			
Scope of delivery	SB 1.0	SB 1.0	SB 2.0 / 2.1	SB 2.0 / 2.1
Parameter at delivery	Actuator with 1 m cable, 4 screws M4 × 100 mm, 4 nuts M4, Allen key for simple manual override			
	5 Nm, 30 s/90°	15 Nm, 30 s/90°	5 Nm, 30 s/90°	15 Nm, 30 s/90°

Approbations

ATEX directive	2014/34/EU
EC type-approved	PTB 04 ATEX 1028 X
IECEX certified	IECEX PTB 07.0057X
Approval for gas	II 2 (1) G Ex d [ia] IIC T6, T5
Approval for dust	II 2 (1) D Ex tD [iaD] A21 IP66 T80, T95°C
CE identification	CE № 0158
EMC directive	2014/30/EU
Low voltage directive	2014/35/EU
Enclosure protection	IP66 in acc. with EN 60529

Special solutions and accessories

...-CTS	Types in aluminium housing with seawater resistant coating, parts nickel-plated
...-VAS	Types in stainless steel housing, parts nickel-plated
ExBox-...	Ex-e terminal boxes for zone 1, 2, 21, 22
MKK-S	Mounting bracket for boxes type ...Box-... directly on actuator
ExSwitch	2 external aux. switches, adjustable for zone 1, 2, 21, 22
HV-S...	Comfortable manual override for ...Max actuators size S
KB-S	Clamp for damper shafts Ø 10...20 mm and □ 10...16 mm
AR-12-xx	Reduction part for 12 mm square connection to 11, 10, 9 or 8 mm shafts
Kit-S8	Cable glands nickel-plated
Adaptions	for dampers and valves on request
ExMax-...-S3	Ambient temperature up to +60 °C (T4), 110...240 VAC/DC, 25 % ED
ExMax-...-S7	Actuator shock approved up to 500 g

ExMax-S-3P_en
V02 – 20-Apr-2016



ExMax-...

ExMax-...-F

ExMax-...-S

ExMax-...-SF



Special options

... -CTS

... -VAS

Electrical connection

All actuators are equipped with a universal supply unit working at a voltage range from 24...240 VAC/DC. The supply unit is self adjusting to the connected voltage!
 The safety operation of the spring return function works if the supply voltage is cut.
 For electrical connection inside hazardous areas an Ex-e terminal box, certificated in acc. with ATEX is required (e.g. ExBox).
 An over-current protection fuse < 10 A has to be provided by installer.
 Note: the initial current is appr. 2 A for 1 second.

Wiring diagram ExMax- ... (without spring return)

On-off / 3-pos. SB 1.0

⚠ Attention ⚠

During commissioning apply a self adjustment drive.

Regard duty cycle at motor running times!

Never use spring return actuators without external load.

Wiring diagram ExMax- ... -F (with spring return)

On-off / 3-pos. SB 2.0

Spring return in ~ 10 s = Standard wiring
Spring return in ~ 3 s = Additional wiring on terminal 5

On-off (1 wire) SB 2.1

Attention!
At 1-wire control mode the heater does not work in case of open contact.

Spring return in ~ 10 s = Standard wiring
Spring return in ~ 3 s = Additional wiring on terminal 5

Wiring diagram ExMax- ... -S and ... -SF

Wiring of integral auxiliary switches SB 3.0

Integral fixed set aux. switches, potential free contacts switching at 5° and 85° angle of rotation max. 24 V / 3 A – 250 V / 0.25 A min. 5 V / 10 mA

Wiring of actuator acc. to type and application see diagrams above

Wiring of the integral, potential free auxiliary switches

Parameters, adjustments and failure indication

Switch – Push button – Lamp for adjustment (behind the blanking plug)

10-position switch (S)
Push button (T)
3-colour LED

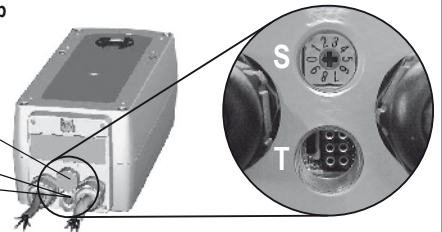

Parameter selection

Example:
ExMax-15.30
Requested parameter:
Torque 30 N
Motor running time 30 s/90°

Type	Torques	
ExMax- 5.10	5 N	10 N
ExMax- 15.30	15 N	30 N
ExMax- 5.10-F	5 N	10 N
ExMax- 15-F	15 N	10 N

Running times	Position of switch (S)	
3 s/90°	00	05
15 s/90°	01	06
30 s/90°	02	07
60 s/90°	03	08
120 s/90°	04	09

Result:
Switch position **07**

Functions, adjustments and parameters

- A) Self adjustment of angle of rotation:**
Switch (S) into position 02 (low torque) or 07 (high torque), then push button (T) for minimum 3 seconds. The actuator will drive into both end positions to be adjusted. LED indicates GREEN.
Adjustment time needs approx. 60 sec. (30 sec. "On", 30 sec. "Off"). After that switch (S) into the position acc. with your required torque and running time.
- B) Selection of running time and torque:**
Put switch (S) into the correct selected position in acc. to above table. The selected parameter will work at next operation of the actuator. Adjustment can be done even without supply voltage. If supply voltage is available turn switch only if actuator is not running.
- C) Running time spring return:**
The running time of 3 or 10 sec. spring return is selected by wiring (see wiring diagrams SB 2.0 and 2.1).
- D) Additional information for 3-pos. operation:**
a closed, b open = direction I a and b closed = motor doesn't work
b closed, a open = direction II a and b open = motor doesn't work
The rotation direction (I and II) depends on left/right mounting of the actuator to the damper/valve. You can change direction of the motor by changing electrical wiring of terminal 3 and 4.

Installation

Ex area – zone 1, 2, 21, 22



Safe area



...Max-...-S or -SF (aux. switches)
24 V / 3 A – 250 V / 0,25 A

Supply*
24...240 VAC/DC ± 10 %

* electrical wiring see diagrams

- Do not open the cover when circuits are live
- Supply cables must be installed in a fixed position and protected against mechanical damage
- Connect potential earth
- Avoid temperature transfer from process (e.g. hot gas) to actuator (note max. ambient temperature!)
- Note ambient temperature
- Close all openings with min. IP66
- Regard all (inter-)national standards, rules and regulations
- Flameproof enclosure is protected against mechanical damages acc. to EN 60079-ff
- For outdoor installation a protective housing against rain, snow and sun should be applied to the actuator, as well as a constant supply at terminal 1 and 2 for the integral heater
- Use for wiring an explosion proof Ex-e terminal box
- Actuators are maintenance free, an annual function test is recommended
- Clean only with damp cloth, avoid dust accumulation



ExMax-...

ExMax-...-F

ExMax-...-S

ExMax-...-SF

 EXPLOSIONPROOF

Special options

... -CTS

... -VAS

Important information for installation and operation

A. Installation, commissioning, maintenance

All national and international standards, rules and regulations for hazardous Ex-areas must be complied. Certified apparatus must be installed in accordance with manufacturer instructions. If the equipment is used in a manner not specified by the manufacturer, the safety protection provided by the equipment may be impaired. For electrical installations design, selection and erection, EN/IEC 60079-14 can be used.

For electrical connection an Ex-e terminal box is required (e.g. ExBox-...).

Attention: If the actuator is put out of operation all Ex rules and regulations must be applied. You have to cut the supply voltage before opening the terminal box!

The cables of the actuator must be installed in a fixed position and protected against mechanical and thermal damage. Connect potential earth. Avoid temperature transfer from armature to actuator! Close all openings with min. IP66.

For outdoor installation a protective weather shield against sun, rain and snow should be applied to the actuator as well as a constant supply at terminal 1 and 2 for the integral heater.

Actuators are maintenance free. An annual inspection is recommended. For electrical installations inspection and maintenance, EN/IEC 60079-17 can be used. Ex-actuators must not be opened by the customer.

B. Manual override

Manual override only if supply voltage is cut. Use delivered socket wrench with slow motions, usage can be tight.

Attention: Releasing or letting go the Allen key too fast at manual operating actuators with spring return causes risk of injury!

C. Shaft connection, selection of running time

Actuators are equipped with a direct coupling double square shaft connection of 12 x 12 mm. For round shafts adaptors/clamping connection (accessories, e.g. KB-S) are available. The housing of the actuator is axially symmetrically built to select Open-close direction of the spring return function by left-/right-mounting. Using the 10-position switch different motor running times and spring return running times can be selected on site in acc. to the actuator type.

D. Operation with 3 sec. motor running time

Note following:

1. The 3 sec. motor running time mode is only available in switch position 0 and 5 and at a constant supply voltage applied for a minimum of 1 minute on terminal 1 and 2.
2. The actuator opens at voltage on terminal 3 (resp. closes) and closes at voltage on terminal 4 (resp. opens) – depending on mounting position of the actuator.
3. The max. duty ratio is 10 % resp. 1 cycle/minute. Between two fully 3 sec. cycles in the same direction there must be a minimum intermission of 1 minute. Trying to run the actuator in the same direction in less than the required minimum of 1 minute the function will be blocked for the rest of the idle period. Later the release for the next cycle is made automatically by an internal timing relay.
4. Same function is applied on spring return actuators, fail safe operation is regarded same as a motor running cycle.
5. Trying to use the 1 wire On-off methode in switch position 0 and 5, software changes the motor running time temporarily and automatically to 15 s/90° to protect the actuator for overheating due to uncontrolled duty ratio.
6. The actuator must be operated with an outside load of at least 3 Nm.
7. After installing the actuator to the damper/armature an automatic alignment has to be accomplished in order to obtain a "gentle" blockade/stop. This function protects the damper/armature by reducing the end position/blockade speed in order to avoid mechanical overload. The actuator aligns specifically once with 30 s/90° onto each end position and recognizes the blockade position in order to reduce the motor performance during operation briefly before reaching the end/blockade position.

E. 3-position control mode

...Max actuators are in the best way suitable for the 3-pos. operation. To protect such elements as gears and mounting elements against harmful influences like minimum pulse time, ...Max actuators are protected via internal electronics. It ignores impulses < 0.5 s, the cyclic duration must be min. 0.5 s. At changing direction the pause is 1 s.

F. Spring return

Spring return function works only if the supply voltage for terminal 1 or 2 is cut. In the event of an electrical interruption, the spring returns to its end position even if supply voltage is available again during return function. Thereafter operation will continue.

G. Operation at ambient temperatures below -20 °C

All actuators are equipped with a regulated integrated heating device designed for employments down to -40 °C ambient temperature. The heater will be supplied automatically by connecting the constant voltage supply on the clamps 1 and 2.

1. After mounting the actuator must be immediately electrically connected.
2. The heater switches on automatically when actuator reaches internally -20 °C. It heats up the actuator to a proper working temperature, then heater switches off automatically. Actuator will not run during heating process.
3. The adjustment options are only ensured after this heating up period.

H. Excess temperatures

In acc. to the ATEX rules and regulations Ex actuators must be protected against excess temperature. The internal thermostat works as a maximum limiter and, in the event of failure at incorrect temperatures, shuts off the actuator irreversibly. An upstream connected temperature sensor stops the actuator before reaching its max. temperature. This safety feature is reversible, after cooling down the actuator is completely functional again. In this case the failure must be eliminated immediately on site!

I. Synchron mode

Do not connect several actuators to one shaft or link mechanically together.

J. Mechanical protection

The actuator must be operated with an outside load of at least 3 Nm. After installing the actuator to the damper/armature an automatic alignment has to be accomplished in order to obtain a "gentle" blockade/stop. This function protects the damper/armature by reducing the end position's/blockade speed in order to avoid mechanical overload. The actuator aligns specifically once with 30 s/90° onto each position and recognizes the blockade position in order to reduce the motor performance during operation briefly before reaching the end/blockade position.

K. Intrinsically safe circuits

The actuator itself has a flameproof enclosure. The supply of the push button (adjustment drive), the 10-position switch (adjustment of torque and running time) and the LED indicator is performed intrinsically safe!

L. Loss of voltage

In switch position 00, 01 and 05, 06 (motor running times 3 sec. and 15 sec.) and after interrupted voltage the actuator (types 5.10 and 15.30 and ...-S) moves in OFF position then the actuators works regarding control signal.

Extra information (see additional data sheet)

Additional technical information, dimensions, installation instruction, illustration and failure indication

Accessory ExSwitch – adaptable Ex-d auxiliary switch



For an end or inclined position indication it is possible to retrofit external, adjustable, explosion proof auxiliary switches type ExSwitch. The switch housing is mounted directly to the actuator and the switches are linked to the actuator's square connector. The switches deliver a potential free output and can be adjusted separately. They are connected by the included cable tail.

Accessory ExBox – adaptable Ex-e terminal box



For electrical connection of ...Max actuators inside the hazardous area an Ex-e terminal box is required. ExBoxes are appropriate terminal boxes and placed at the disposal. To adapt the ...Box directly to the actuator housing a mounting bracket type MKK-S is required.

ExBox- 3P for ...Max-... and ...Max-...-F
 ExBox- Y/S for ...Max-...-S and ...-SF with integral auxiliary switches

A.8 Anti-frost thermostat

Name	Data
Designation	Anti-frost thermostat
Type	ExBin-FR
Number	
Type of manual	Instruction manual
Manufacturer	Schischek

ExBin-FR Frost protection thermostat

ExBin - FR3
ExBin - FR6
ExBin - FR... -CT

Subject to change!

Electrical, explosion-proof frost protection thermostat

24 VAC/DC supply voltage, potential free relay output

EC type-approved in acc. with ATEX directive 2014/34/EU for zone 1, 2, 21, 22

Compact. Easy installation. Universal. Cost effective. Safe.

Type	Capillary length	Supply	Output	Max. ratings	Wiring diagram
ExBin- FR3	3 m	24 VAC/DC	Relay contact	250 VAC, 0.1 A / 30 V, 0.5 A	SB 1.0
ExBin- FR6	6 m	24 VAC/DC	Relay contact	250 VAC, 0.1 A / 30 V, 0.5 A	SB 1.0
ExBin- FR... - CT	Types as above with aluminium housing and seawater resistant coating (sensor connection and cable glands brass nickel-plated, screws in stainless steel)				

Product views and applications

Frost protection thermostat



...Bin-FR...-CT



Description

The ExBin-FR... frost protection thermostat is a revolution in HVAC systems, in chemical, pharmaceutical, industrial and offshore/onshore plants, for use in hazardous areas zone 1, 2 (gas) and zone 21, 22 (dust).

Highest protection class (ATEX) and IP66 protection, small dimensions, universal functions and technical data guarantee safe operation even under difficult environmental conditions.

All frost protection thermostats are programmable on site without any additional tools. The switching point is scalable within the maximum ranges.

Highlights

- ▶ For all types of gases, mists, vapours and dust for use in zone 1, 2, 21 and 22
- ▶ Power supply 24 VAC/DC
- ▶ Output potential free switching contact
- ▶ Integrated Ex-e terminal box
- ▶ No additional Ex-i module required
- ▶ No intrinsically safe wiring/installation between panel and sensor required
- ▶ No intrinsically safe wiring/installation and no space in the panel required
- ▶ LED switching state indication
- ▶ Compact design and small dimension
- ▶ Robust aluminium housing (optional with seawater resistant coating)
- ▶ IP66 protection



Technical data	ExBin	...-FR3	...-FR6
Supply voltage, frequency	24 VAC/DC \pm 20 % (19,2...28,8 VAC/DC), 50/60 Hz		
Current, power consumption	150 mA, ~ 4 W, internal fuse 500 mA, not removable		
Galvanic isolation	Supply for relay output min. 1,5 kV		
Electrical connection	Terminals 0,14...2,5 mm ² at integrated Ex-e terminal box, stripping length 9 mm, torque 0,4...0,5 Nm, equipotential bonding 4 mm ²		
Cable glands	2 x M16 x 1,5 mm, Ex-e approved, for cable diameter ~ \varnothing 5...9 mm		
...-CT	2 x M16 x 1,5 mm, Ex-e approved, brass nickel-plated, for cable diameter ~ \varnothing 6...10 mm		
Control elements	Rotary control for setpoint adjustment and fixing screw		
Measuring range	Setpoint adjustable -10 °C...+15 °C		
Status indication	via LEDs – GREEN: ambient temperature is above setpoint (normal), RED: ambient temperature is below setpoint		
Housing material	Aluminium die-cast housing, coated. Optional with seawater resistant coating (...-CT)		
Dimensions (L x B x H)	~ 180 x 107 x 66 mm (without connectors)		
Weight	~ 950 g		
Ambient temperature	-20...+50 °C, capillary max. +80 °C, storage temperature -35...+70 °C		
Temperature class	T6 (T80 °C) bei -20...+50 °C		
Ambient humidity	0...95 % rH, non condensing		
Sensor circuit	Internal intrinsically safe (IS) circuit		
Capillary	Length	3 m \pm 15 cm	6 m \pm 20 cm
	min. active length	~ 40 cm	
	min. bending radius	2 cm	
Hysteresis	~ 6 K, accuracy of setpoints \pm 3 K		
Start delay	5 s		
Output	Potential free switching contact – breaking contact		
	max. rating load	0,5 A (30 VAC/DC) – 0,1 A (250 VAC) – 0,1 A (220 VDC)	
	min. rating load	10 mW / 0,1 V / 1 mA	
Duration of life	mechanical	10 x 10 ⁶	
	electrical (rated load)	100 x 10 ³	
Wiring diagram	SB 1.0		
Scope of delivery	Frost protection thermostat, self-tapping screws 4,2 x 13 mm resp. in stainless steel (with ...-CT versions)		

Approbationen

ATEX directive	2014/34/EU
EC type-approved	EPS 14 ATEX 1 657
IECEx certified	IECEx EPS 14.0074
Approval for gas	II 2 (1) G Ex e mb [ia Ga] IIC T6 Gb
Types ...-CT	II 2 (1) G Ex e mb [ia Ga] IIB T6 Gb
Approval for dust	II 2 (1) D Ex tb [ia Da] IIIC T80°C Db IP66
CE identification	CE № 0158
EMC directive	2014/30/EU
Enclosure protection	IP66 in acc. with EN 60529
EAC	TC RU C-DE.ГБ08.B.01510

Accessories

MKR	Mounting bracket for round ducts up to \varnothing 600 mm
Installation Kit 1.3	Assembly cramp and 4 assembly brackets for ...Bin-FR3
Installation Kit 1.6	Assembly cramp and 8 assembly brackets for ...Bin-FR6

Dimensions [mm]

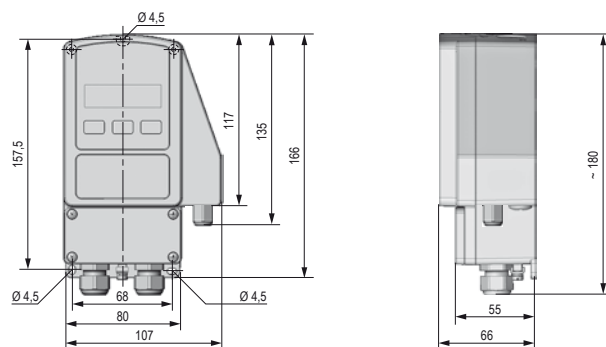

Electrical connection

All frost protection thermostats require a 24 VAC/DC power supply. The electrical wiring must be realized via the integrated Ex-e terminal box acc. to ATEX. The terminals' type of protection is "Increased safety Ex-e".

Attention: Before opening the terminal box cover, the supply voltage must be shut off! The supply has to be connected at terminals 1 (-/-) and 2 (+/-).

At different relay and supply voltages (24 VAC/DC) the cable installation must be considered (see "Information for Installation")!

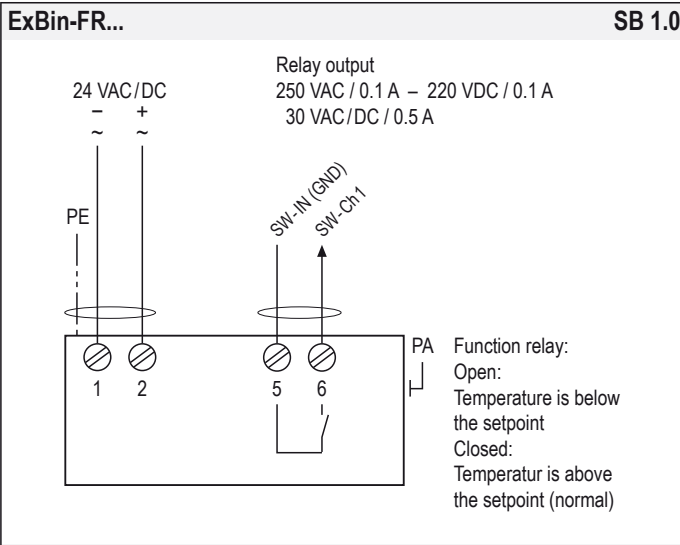

Intrinsically safe parameters (IS) – Internal contact

$U_o = 7.14 \text{ V}$	$C_i \rightarrow 0$	IIC	IIB	IIA	
$I_o = 8 \text{ mA}$	$L_i \rightarrow 0$	L_o	5 mH	10 mH	20 mH
$P_o = 15 \text{ mW}$		C_o	1.5 μF	6.7 μF	8.6 μF

Control elements with status indication

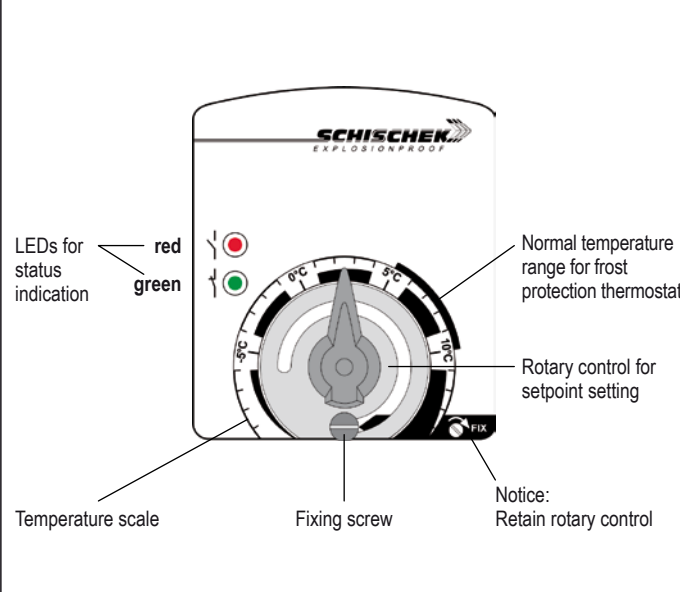

A. Installation, commissioning, maintenance

All national and international standards, rules and regulations must be complied with. Certified apparatus must be installed in accordance with manufacturer instructions. If the equipment is used in a manner not specified by the manufacturer, the safety protection provided by the equipment may be impaired. For electrical installations design, selection and erection, EN/IEC 60079-14 can be used.

Attention: Apply all Ex rules and regulation before opening the internal terminal box. Do not open cover when circuits are live!

Draw the wiring cables through the cable glands. For connection use the internal Ex-e approved terminal box and connect equipotential bonding. After connection install the cables in a fixed position and protect them against mechanical and thermal damage. Close all openings and ensure IP protection (min. IP66). Avoid temperature transfer and ensure not to exceed max. ambient temperature! For outdoor installation a protective shield against sun, rain and snow should be applied. Sensors are maintenance free. An annual inspection is recommended. For electrical installations inspection and maintenance, EN/IEC 60079-17 can be used. Clean with damp cloth only. Ex sensors must not be opened and repaired by the end user.

B. Long cabling

We recommend using shielded signal wires and to connect one end of the shield to the ...Bin... terminal box.

C. Separate ground wires

For supply and signal wires use separate grounds.

D. Relay output

Wires for safety extra-low voltage must be installed separately from other circuits. At 24 VAC/DC only supply and signal wires are permitted in one cable, in all other cases use separate or double isolated cables. An over-current protection fuse < 10 A has to be provided by the installer.

Installation

Hazardous (classified) locations			Nonhazardous locations
		<p>Relais output 250 V AC / 0.1 A 220 V DC / 0.1 A 30 V AC/DC / 0.5 A</p>	
		<p>Supply * 24 V AC/DC \pm 20 %</p> <p>* electrical wiring see diagram</p>	
<p>▪ Do not crack the capillary, note capillary's bending radius</p>			

A.9 Pressure switch/Differential pressure switch

Name	Data
Designation	Pressure switch/Differential pressure switch
Type	ExBin-P
Number	
Type of manual	Instruction manual
Manufacturer	Schischek



ExBin-P Pressure switches 5 Pa ... 5.000 Pa

Electrical, explosion-proof binary pressure/differential pressure switches

5 Pa...100 Pa with adjustable switch activation delay

24 VAC/DC supply voltage, output potential free switching contact

EC type-approved in acc. with ATEX directive 2014/34/EU for zone 1, 2, 21, 22

ExBin - P- ...
ExBin - P- ... - 2
ExBin - ... - CT
ExBin - ... - OCT
ExBin - ... - VA
ExBin - ... - OVA

Subject to change!

Compact. Easy installation. Universal. Cost effective. Safe.

Type	Switch	Supply	Range	min. Setting	max. Pressure	Activation delay	Output switch	Wiring diagram	
ExBin- P- 100	Pressure	24 VAC/DC	0... 100 Pa	5 Pa	5.000 Pa	0...240 s	potential free contact	SB 1.0	
ExBin- P- 500	Pressure	24 VAC/DC	0... 500 Pa	25 Pa	5.000 Pa	-	potential free contact	SB 1.0	
ExBin- P-5000	Pressure	24 VAC/DC	0...5.000 Pa	250 Pa	50.000 Pa	-	potential free contact	SB 1.0	
ExBin- P- ... - 2	Types ...P-500 und ...P-5000 as above with additional switching output							2 × potential free contact	SB 1.0
ExBin- P- ... - CT	Types as above with aluminium housing and seawater resistant coating (cable glands M16 brass nickel-plated, screws in stainless steel)								
ExBin- P- ... - OCT	Types as above, offshore version with aluminium housing and seawater resistant coating (stainless steel tubes for clamping ring connection, cable glands M20 brass nickel-plated, screws in stainless steel)								
ExBin- P- ... - VA	Types as above with stainless steel housing for aggressive ambient (cable glands M20 brass nickel-plated, screws in stainless steel)								
ExBin- P- ... - OVA	Types as above, offshore version with stainless steel housing for aggressive ambient (tubes for clamping ring connection and screws in stainless steel, cable glands M20 brass nickel-plated)								

Product views and applications

Figures ...Bin-P-...-2

Pressure/Diff. press. switch



...Bin-P-...-CT



...Bin-P-...-VA



Offshore ...-OCT



Offshore ...-OVA



Description

The ExBin-P-... pressure switch generation from 5...5000 Pa (acc. to type) is a revolution for differential pressure switches in HVAC systems, in chemical, pharmaceutical, industrial and offshore/onshore plants, for use in hazardous areas zone 1, 2 (gas) and zone 21, 22 (dust).

Highest protection class (ATEX) and IP66 protection, small dimensions, universal functions and technical data guarantee safe operation even under difficult environmental conditions.

All pressure switches are programmable on site without any additional tools. The switching points are scalable within the maximum ranges. The integrated display is for parametrisation and an actual value indication at working mode (can be switched off as needed).

...Bin-P-...-2 sensors are equipped with an additional switching output (2-stage), which can be parametrised independently.

...Bin-P-...-OCT and ...-OVA offshore versions are equipped with stainless steel tubing Ø 6 mm.

Highlights

- ▶ For all types of gases, mists, vapours and dust for use in zone 1, 2, 21 and 22
- ▶ Power supply 24 VAC/DC
- ▶ Potential free switching contact output
- ▶ Adjustable switching threshold, hysteresis and start-up bypass time
- ▶ Adjustable switch activation delay (acc. to type)
- ▶ Integrated Ex-e terminal box
- ▶ No additional Ex-i module required
- ▶ No intrinsically safe wiring/installation between panel and sensor required
- ▶ No intrinsically safe wiring/installation and no space in the panel required
- ▶ Optional second switching output (acc. to type)
- ▶ Display with backlight, can be switched off
- ▶ Password locking
- ▶ Down to -20 °C ambient temperature applicable
- ▶ Compact design and small dimension
- ▶ Robust aluminium housing (optional with seawater resistant coating) or in stainless steel
- ▶ IP66 protection
- ▶ Offshore versions with pressure tube connection for clamping ring Ø 6 mm



Technical data	...-P-100	...-P-500	...-P-5000
Supply voltage, frequency	24 VAC/DC $\pm 20\%$ (19,2...28,8 VAC/DC), 50/60 Hz		
Current, power consumption	150 mA, ~ 4 W, internal fuse 500 mA, without bracket, not removable		
Galvanic isolation	Supply for relay output min. 1,5 kV		
Electrical connection	Terminals 0,14...2,5 mm ² at integrated Ex-e terminal box, stripping length 9 mm, torque 0,4...0,5 Nm, equipotential bonding 4 mm ²		
Cable glands	2 x M16 x 1,5 mm, Ex-e approved, for cable diameter ~ \varnothing 5...9 mm		
Cable glands ...-CT	2 x M16 x 1,5 mm, Ex-e approved, brass nickel-plated, for cable diameter ~ \varnothing 6...10 mm		
...-VA, ...-OCT, ...-OVA	2 x M20 x 1,5 mm, Ex-e approved, brass nickel-plated, for cable diameter ~ \varnothing 6...13 mm		
Protection class	Class I (grounded)		
Display	LC-Display, backlight, for configuration, user guidance, parameter and actual value indication. Status indicator via LEDs		
Control elements	3 buttons for configuration		
Housing material	Aluminium die-cast housing, coated. Optional with seawater resistant coating (...-CT/...-OCT) or stainless steel housing, № 1.4581 / UNS-J92900 / similar AISI 316Nb (...-VA/...-OVA)		
Dimensions (L x W x H)	Aluminium housing ~ 180 x 107 x 66 mm, stainless steel housing ~ 195 x 127 x 70 mm (each without connectors)		
Weight	~ 950 g aluminium housing, stainless steel version ~ 2,5 kg		
Ambient temperature	-20...+50 °C, storage temperature -35...+70 °C		
Temperature class	Aluminium housing T6 (T80 °C) at -20...+50 °C Stainless steel housing T5 (T95 °C) at -20...+40 °C, T4 (T130 °C) at -20...+50 °C		
Ambient humidity	0...95 % rH, non condensing		
Sensor circuit	Internal intrinsically safe (IS) circuit		
Sensor	Piezo pressure transmitter, installation in Ex zone		
Pressure connection	P+ / P- sleeves \varnothing 4...6 mm. OCT versions have 2 stainless steel (316L) tube connections for clamp ring fittings \varnothing 6 mm		
Measuring range	0...100 Pa	0...500 Pa	0...5000 Pa
	Minimum measuring range is 5 % of full range (e.g. 25 Pa at ...500 Pa switch)		
Response time of sensor	T90 / 5 s		
Accuracy of pressure	< $\pm 1\%$ typically, max. $\pm 5\%$ of end value ± 1 Pa		
Setting range hysteresis	0,1...10 Pa (factory setting 2 Pa)	0,5...50 Pa (factory setting 10 Pa)	5...500 Pa (factory setting 100 Pa)
Start delay	5 s		
Start-up bypass time (AUB)	3...240 s (factory setting 120 s)		
Switch activation delay	0...240 s (factory setting 0 s / Off)	–	–
Setting zero point	Via menu. Short-circuit mechanically both tube connectors P+ / P- for the moment of zero point setting		
Output	Potential free switching contact – breaking/making contact, adjustable per menu max. rating load: 0,5 A (30 VAC/DC) – 0,1 A (250 VAC) – 0,1 A (220 VDC); min. rating load: 10 mW / 0,1 V / 1 mA		
Additional relay output (type ...-2)	–	as above	as above
Duration of life Mechanical	10 x 10 ⁶		
Electrical (rated load)	100 x 10 ³		
Wiring diagram	SB 1.0		
Scope of delivery	Pressure switch, 3 self-tapping screws 4,2 x 13 mm resp. in stainless steel (with ...CT and ...VA versions), short circuit tube		

Approbations	
ATEX directive	2014/34/EU
EC type-approved	EPS 14 ATEX 1 657
IECEx certified	IECEx EPS 14.0074
Approval for gas	II 2 (1) G Ex e mb [ia Ga] IIC T6...T4 Gb
Types ...-CT, ...-OCT	II 2 (1) G Ex e mb [ia Ga] IIB T6 Gb
Approval for dust	II 2 (1) D Ex tb [ia Da] IIIC T80°C...T130°C Db IP66
CE identification	CE № 0158
EMC directive	2014/30/EU
Enclosure protection	IP66 in acc. with EN 60529
EAC	TC RU C-DE.ГБ08.В.01510

Special solutions and accessories	
...-CT	Types in aluminium housing with seawater resistant coating, parts nickel-plated
...-OCT	Offshore version in aluminium housing with seawater resistant coating, parts nickel-plated
...-VA	Types in stainless steel housing, parts nickel-plated
...-OVA	Offshore version in stainless steel housing, parts nickel-plated
MKR	Mounting bracket for round ducts up to \varnothing 600 mm
Kit 2	Flexible pressure tube, 2 m, inner \varnothing 6 mm, 2 connection nipples
Kit-S8-CBR	2 cable glands M16 x 1,5 mm, Ex-e, brass nickel-plated, for cable \varnothing 5...10 mm
Kit-Offs-GL-CBR	2 cable glands M20 x 1,5 mm, Ex-d, Ms-Ni, for armoured cables
Kit-PTC-CBR	2 connecting tubes for tube fittings \varnothing 6 mm, stainless steel 316 L

Electrical connection

All pressure switches require a 24 VAC/DC power supply. The electrical wiring must be realized via the integrated Ex-e terminal box acc. to ATEX. The terminals' type of protection is "Increased safety Ex-e".

Attention: Before opening the terminal box cover, the supply voltage must be shut off! The supply has to be connected at terminals 1 (-/-) and 2 (+/-). The start-up bypass delay (AUB) can be activated by bridging terminals 2-3. Activation is indicated by a flashing green LED.

At different relay and supply voltages (24 VAC/DC) the cable installation must be considered (see "Information for Installation")!

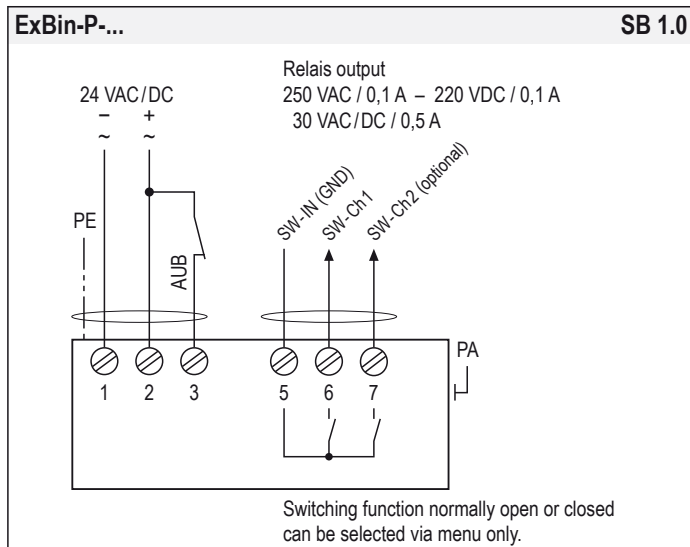

Zero point compensation

...Bin-P-... pressure switches are equipped with a zero point compensation to adjust the module to the installation position. The pressure nipples P+ / P- must be connected with a short circuit tube and the zero point compensation performed by following the menu for parametrisation (menu 14).

Before starting the zero point compensation, the device should be connected to power supply for a minimum of 15 minutes to reach the uniform working temperature!

Display, buttons and parameters

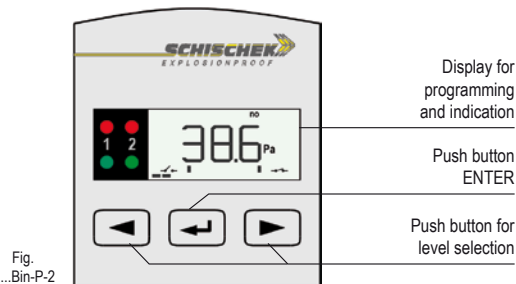

Change operation – parametrisation mode

To change from operation to parametrisation mode and vice versa, push ENTER button for minimum of 3 seconds. Back to operation mode with menu "save".

Indication of data logging

A flashing unit symbol (star) in the display shows that data is received and the device is working.

Password input

The default/delivery setup is 0000. In this configuration the password input is not activated. To activate the password protection (menu 15) change the 4 digits into your chosen numbers (e.g. 1234) and press ENTER. Please keep your password in mind for next parameter change! Due to a new parameter setup the password is requested.

Important information for installation and operation

A. Installation, commissioning, maintenance

All national and international standards, rules and regulations must be complied with. Certified apparatus must be installed in accordance with manufacturer instructions. If the equipment is used in a manner not specified by the manufacturer, the safety protection provided by the equipment may be impaired. For electrical installations design, selection and erection, EN/IEC 60079-14 can be used.

Attention: Apply all Ex rules and regulation before opening the internal terminal box. Do not open cover when circuits are live!

Draw the wiring cables through the cable glands. For connection use the internal Ex-e approved terminal box and connect equipotential bonding. After connection install the cables in a fixed position and protect them against mechanical and thermal damage. Close all openings and ensure IP protection (min. IP66). Avoid temperature transfer and ensure not to exceed max. ambient temperature! For outdoor installation a protective shield against sun, rain and snow should be applied. After mounting and installation a zero point compensation must be done to ensure correct measurement results (see description). Sensors are maintenance free. An annual inspection is recommended. For electrical installations inspection and maintenance, EN/IEC 60079-17 can be used. Clean with damp cloth only. Ex sensors must not be opened and repaired by the end user.

B. Long cabling

We recommend using shielded signal wires and to connect one end of the shield to the ...Bin-... terminal box.

C. Separate ground wires

For supply and signal wires use separate grounds.

D. Relais output

Wires for safety extra-low voltage must be installed separately from other circuits. At 24 VAC/DC only supply and signal wires are permitted in one cable, in all other cases use separate or double isolated cables. An over-current protection fuse < 10 A has to be provided by the installer.



Dimensions [mm]

Aluminium housing

...Bin-P...-OCT

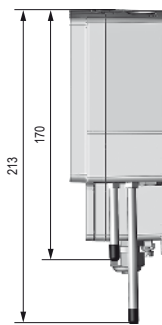
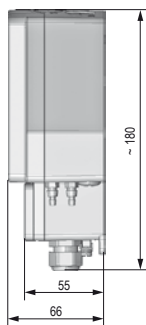
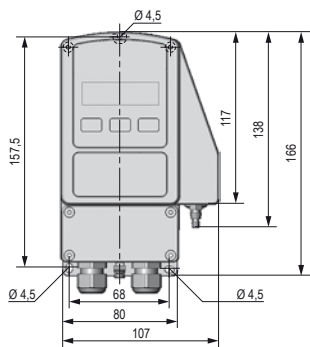

Stainless steel housing

...Bin-P...-OVA

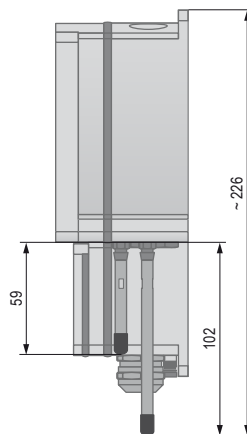
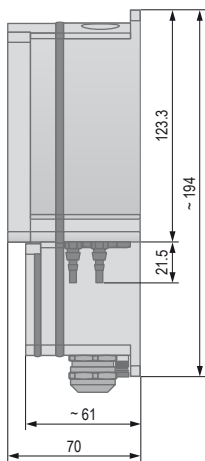
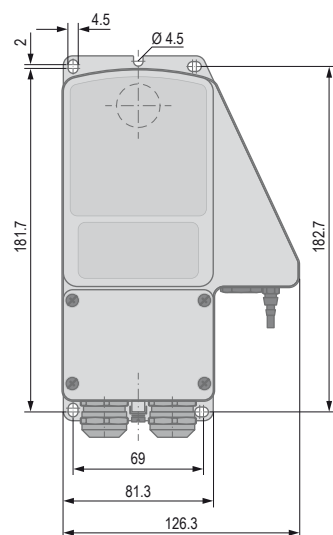

Parametrisation and commissioning

To change from operation to parametrisation mode push the "ENTER" button for minimum 3 seconds.
If password protected: type password and push .
Skip menu with , back to operation mode with menu "save".

Operation → Parametrisation push for min. 3 s



Menu	Function	ENTER	Indication	Select	ENTER	Next indication	Select	ENTER	Next menu
Menu 1	Preset Select application	PSEt	Menu 1 PRO						
Menu 2	Unit sensor Select physical unit	Un it	Menu 2 Pa				Pa, mbar, inH ₂ O		
Menu 3	set 1 Select switching point 1	SEt 1	Menu 3 1000 Pa				enter setpoint		
Menu 4	set 2 (optional)* Select switching point 2	SEt 2	Menu 4 4000 Pa				enter setpoint		
Menu 5	hysteresis** Select hysteresis	HYS t	Menu 5 100 Pa				enter hysteresis		
Menu 6	mode** Select switching properties (break contact, make contact)	Mode	Menu 6 UP			Menu 6 nc			
Menu 7	no function – menu skip								

Continue next page

ExBin-P_en
V02 – 18-Oct-2016



Continue Parametrisation

Menu	Function	ENTER	Indication	Select	ENTER	Next indication	Select	ENTER	Next menu
Menu 8	no function – menu skip								
Menu 9	no function – menu skip								
Menu 10	no function – menu skip								
Menu 11	no function – menu skip								
Menu 12	time Select bypass (AUB) time								
Menu 13	display setting Select display								
Menu 14	Zero point compensation Sensor's calibration for its installation position								
Menu 15	security Select password protection								
Menu 16	save Select: save data, discard, back to menu, factory setting								(operation mode after "save")

* for ...Bin-P...-2 only (2-stage)

** adjustable in professional mode only (menu 1)

Menu 1 "pset" – Preset

For some applications you can select presetting to ease parametrisation. Besides fan belt („FAN“) and filter monitoring („FILT“) the professional mode („PRO“) is available for further applications.

Professional mode

Menu 1
PRO

When this mode is selected the switching properties can be set at will per menu 5 ("hysteresis") and 6 ("mode") acc. to requirements.

Fan speed monitoring

Menu 1
FAN

The preset "FAN" hides menu 5 ("hysteresis") and 6 ("mode") during parametrisation. The corresponding values are set automatically.

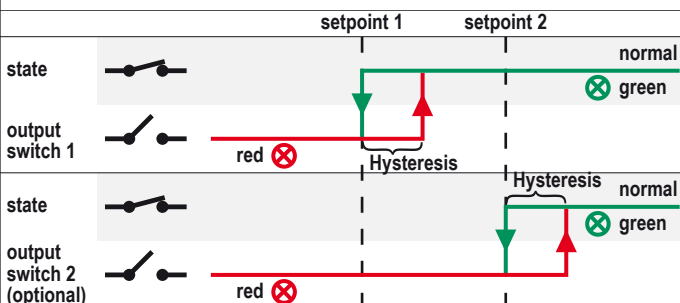
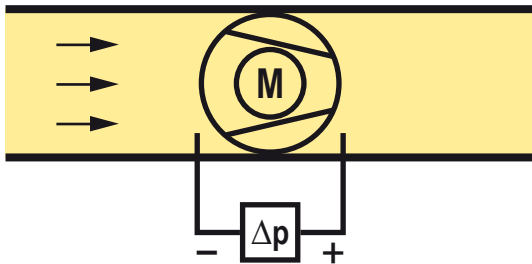

Filter monitoring

Menu 1
FILT

The preset "FILT" hides menu 5 ("hysteresis") and 6 ("mode") during parametrisation. The corresponding values are set automatically.

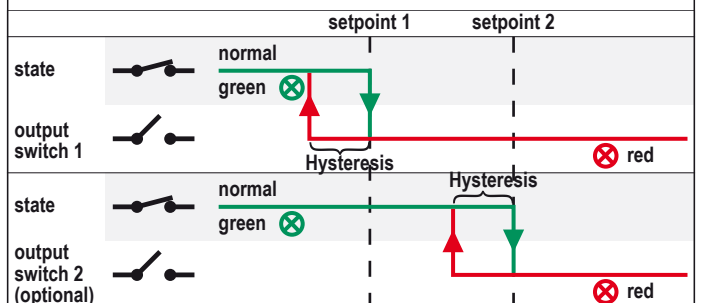
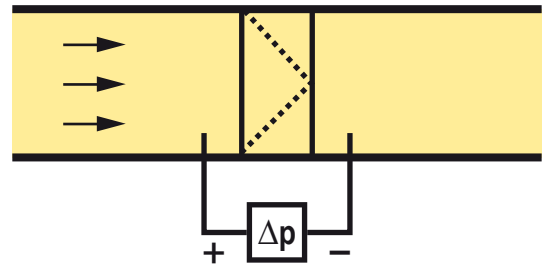

Menu 6 "mode" – Switching properties

1. Define the device's normal range first:

- The device should indicate (green LED) when the temperature/humidity is
 - above the setpoints – mode „up-range“ has to be selected.
 - under the setpoints – mode „down-range“ has to be selected.
 - between the setpoints – mode „mid-range“ has to be selected.
- This mode is available for 2-stage devices only (...Bin-P...-2).

2. Select the switching characteristic of the output relay:

- When the measured value is in normal range, the corresponding relays shall
 - close – select "normally closed" (nc)
 - open – select "normally open" (no)

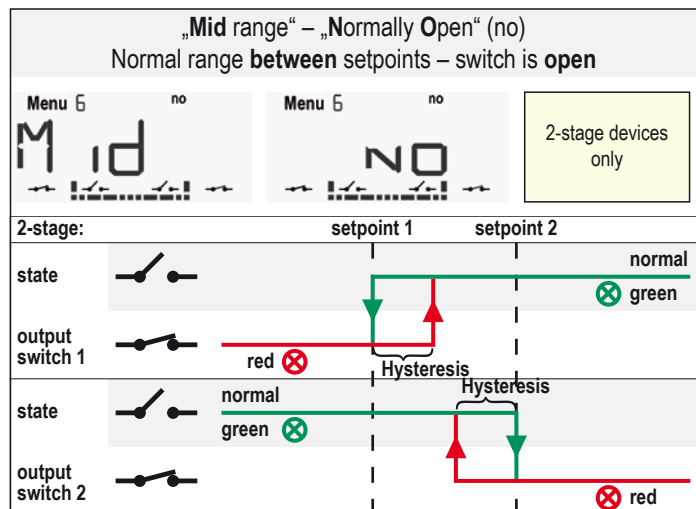
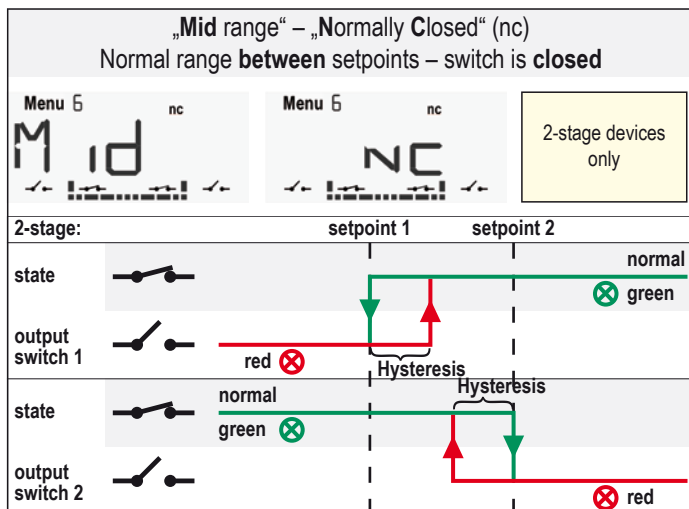
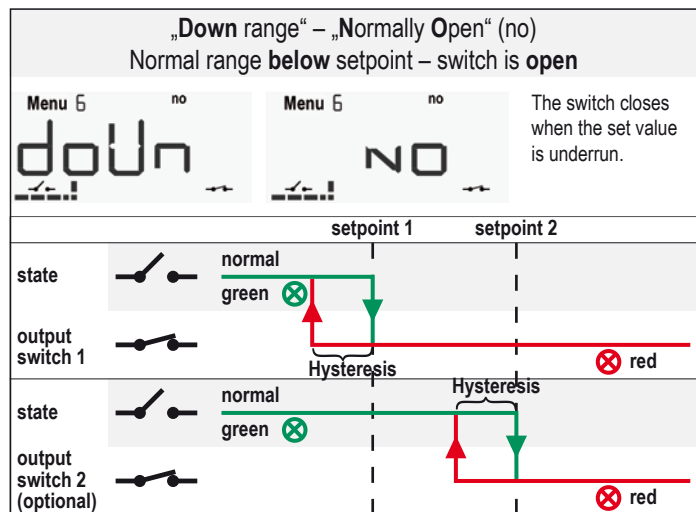
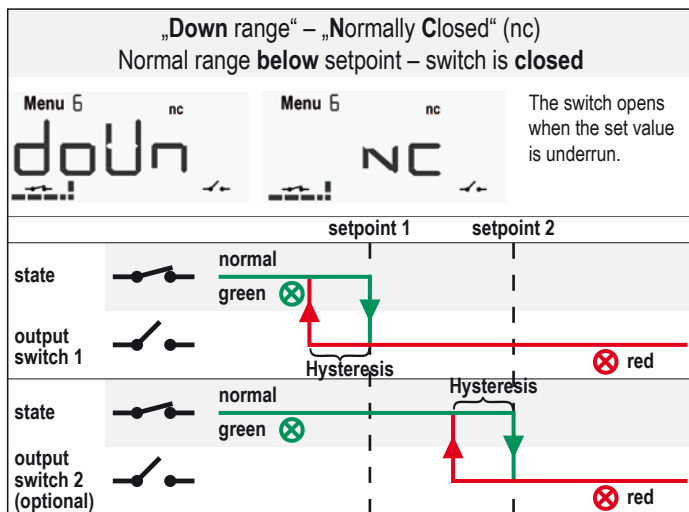
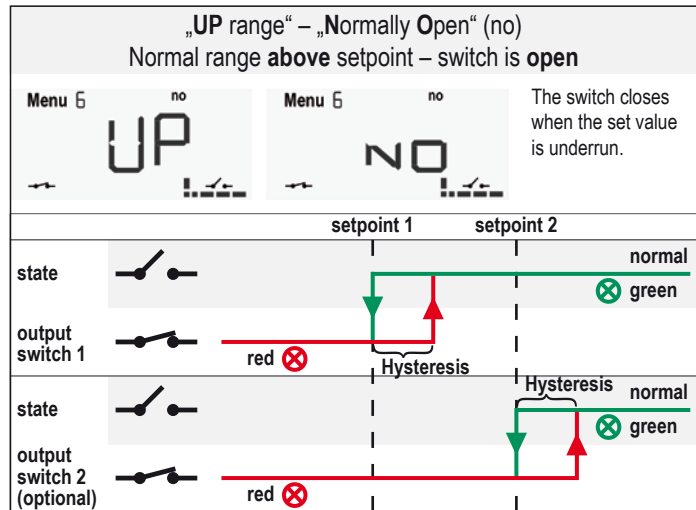
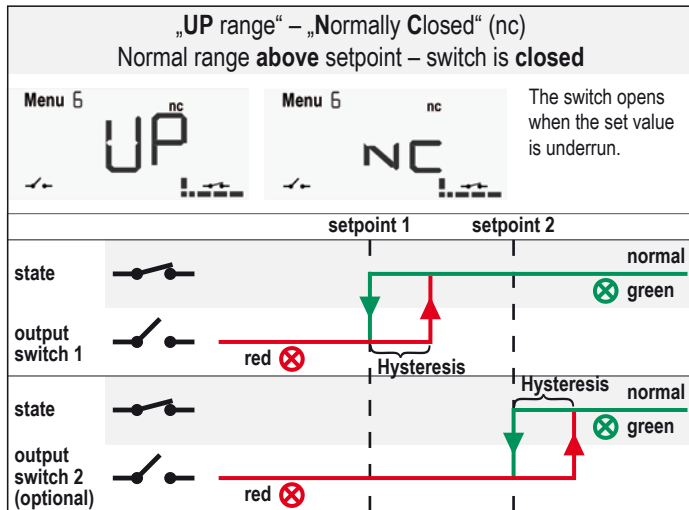

A.10 Pressure sensors

Name	Data
Designation	Pressure sensors
Type	ExCos-P
Number	
Type of manual	Instruction manual
Manufacturer	Schischek



ExCos-P Pressure sensor 20 Pa ... 7.500 Pa

Electrical, explosion-proof pressure/differential pressure sensors
24 VAC/DC supply voltage, 0...10 V/(0)4...20 mA analogue output
EC type-approved in acc. with ATEX directive 2014/34/EU for zone 1, 2, 21, 22

ExCos - P- ...
ExCos - P- ... - A
ExCos - ... - CT
ExCos - ... - OCT
ExCos - ... - VA
ExCos - ... - OVA

Subject to change!

Compact. Easy installation. Universal. Cost effective. Safe.

Type	Sensor	Supply	Range	min. Setting	max. Pressure	Output	Ex-i output	Wiring diagram
ExCos-P-100	Pressure/Diff. press.	24 VAC/DC	± 100 Pa	20 Pa	25.000 Pa	(0)4...20 mA / 0...10 V	-	SB 1.0
ExCos-P-250	Pressure/Diff. press.	24 VAC/DC	± 250 Pa	50 Pa	25.000 Pa	(0)4...20 mA / 0...10 V	-	SB 1.0
ExCos-P-500	Pressure/Diff. press.	24 VAC/DC	± 500 Pa	100 Pa	50.000 Pa	(0)4...20 mA / 0...10 V	-	SB 1.0
ExCos-P-1250	Pressure/Diff. press.	24 VAC/DC	± 1.250 Pa	250 Pa	50.000 Pa	(0)4...20 mA / 0...10 V	-	SB 1.0
ExCos-P-2500	Pressure/Diff. press.	24 VAC/DC	± 2.500 Pa	500 Pa	50.000 Pa	(0)4...20 mA / 0...10 V	-	SB 1.0
ExCos-P-5000	Pressure/Diff. press.	24 VAC/DC	± 5.000 Pa	1.000 Pa	75.000 Pa	(0)4...20 mA / 0...10 V	-	SB 1.0
ExCos-P-7500	Pressure/Diff. press.	24 VAC/DC	± 7.500 Pa	1.500 Pa	120.000 Pa	(0)4...20 mA / 0...10 V	-	SB 1.0
ExCos-P-...-A	Types as above with additional intrinsically safe analogue output to connect an external digital indicator						(0)4...20 mA	SB 3.1
ExCos-P-...-CT	Types as above with aluminium housing and seawater resistant coating (cable glands M16 brass nickel-plated, screws in stainless steel)							
ExCos-P-...-OCT	Types as above, offshore version with aluminium housing and seawater resistant coating (stainless steel tubes for clamping ring connection, cable glands M20 brass nickel-plated, screws in stainless steel)							
ExCos-P-...-VA	Types as above with stainless steel housing for aggressive ambient (cable glands M20 brass nickel-plated, screws in stainless steel)							
ExCos-P-...-OVA	Types as above, offshore version with stainless steel housing for aggressive ambient (tubes for clamping ring connection and screws in stainless steel, cable glands M20 brass nickel-plated)							

Product views and applications

Pressure/Differential press.



...Cos-P...-CT



...Cos-P...-VA



Offshore ...-OCT



Offshore ...-OVA



Description

The ExCos-P... pressure sensor generation from ± 100 Pa to ± 7.500 Pa (acc. to type) is a revolution for differential pressure measuring in HVAC systems, in chemical, pharmaceutical, industrial and offshore/onshore plants, for use in hazardous areas zone 1, 2 (gas) and zone 21, 22 (dust).

Highest protection class (ATEX) and IP66 protection, small dimensions, universal functions and technical data guarantee safe operation even under difficult environmental conditions.

All sensors are programmable on site without any additional tools. The measuring ranges are scalable within the maximum ranges. At ...Cos-P-100 the smallest ΔP range is 20 Pa. The analogue output signal is either 0...10 VDC or (0)4...20 mA and can be selected on site. The integrated display is for parametrisation and an actual value indication at working mode (can be switched off as needed).

...Cos-P...-A sensors are equipped with an additional intrinsically safe (IS) output, e.g. for an external indicator.

...Cos-P...-OCT and ...-OVA offshore versions are equipped with stainless steel tubing Ø 6 mm.

Highlights

- ▶ For all types of gases, mists, vapours and dust for use in zone 1, 2, 21 and 22
- ▶ Power supply 24 VAC/DC
- ▶ Scalable analogue output, selectable 0...10 V / (0)4...20 mA
- ▶ Integrated Ex-e terminal box
- ▶ No additional Ex-i module required
- ▶ No intrinsically safe wiring/installation between panel and sensor required
- ▶ No intrinsically safe wiring/installation and no space in the panel required
- ▶ Optional IS-output (0)4...20 mA for external indicator in Ex-areas
- ▶ Display with backlight, can be switched off
- ▶ Password locking
- ▶ Down to -20 °C ambient temperature applicable
- ▶ Compact design and small dimension
- ▶ Robust aluminium housing (optional with seawater resistant coating) or in stainless steel
- ▶ IP66 protection
- ▶ Offshore versions with pressure tube connection for clamping ring Ø 6 mm

Technical data

Supply voltage, frequency	24 VAC/DC $\pm 20\%$ (19,2...28,8 VAC/DC), 50/60 Hz
Current, power consumption	150 mA, ~ 4 W, internal fuse 500 mA, without bracket, not removable
Galvanic isolation	Supply for analogue in- and outputs min. 1,5 kV, supply for relay output min. 1,5 kV
Electrical connection	Terminals 0,14...2,5 mm ² at integrated Ex-e terminal box, stripping length 9 mm, torque 0,4...0,5 Nm, equipotential bonding 4 mm ²
Cable glands	2 x M16 x 1,5 mm, Ex-e approved, for cable diameter ~ \varnothing 5...9 mm
Cable glands ...-CT	2 x M16 x 1,5 mm, Ex-e approved, brass nickel-plated, for cable diameter ~ \varnothing 6...10 mm
...-VA, ...-OCT, ...-OVA	2 x M20 x 1,5 mm, Ex-e approved, brass nickel-plated, for cable diameter ~ \varnothing 6...13 mm
Protection class	Class I (grounded)
Display	2 x 16 digits, dot-matrix display, backlit, for configuration, user guidance, parameter and actual value indication
Control elements	3 buttons for configuration
Housing material	Aluminium die-cast housing, coated. Optional with seawater resistant coating (...-CT/...-OCT) or stainless steel housing, № 1.4581 / UNS-J92900 / similar AISI 316Nb (...-VA/...-OVA)
Dimensions (L x W x H)	Aluminium housing ~ 180 x 107 x 66 mm, stainless steel housing ~ 195 x 127 x 70 mm (each without connectors)
Weight	~ 950 g aluminium housing, stainless steel version ~ 2,5 kg
Ambient temperature	-20...+50 °C, storage temperature -35...+70 °C
Temperature class	Aluminium housing T6 (T80 °C) at -20...+50 °C Stainless steel housing T5 (T95 °C) at -20...+40 °C, T4 (T130 °C) at -20...+50 °C
Ambient humidity	0...95 % rH, non condensing
Sensor circuit	Internal intrinsically safe (IS) circuit
Sensor	Piezo pressure transmitter
Pressure connection	P+ / P- sleeves \varnothing 4...6 mm. OCT versions have 2 stainless steel (316L) tube connections for clamp ring fittings \varnothing 6 mm
Measuring range	± 100 Pa, ± 250 Pa, ± 500 Pa, ± 1.250 Pa, ± 2.500 Pa, ± 5.000 Pa, ± 7.500 Pa in acc. to type Minimum measuring range is 20 % of full range (e.g. 20 Pa at ± 100 Pa sensor)
Response time of sensor	T90 / 5 s
Accuracy of pressure	< $\pm 1\%$ typically, max. $\pm 2\%$ of end value ± 1 Pa
Non linearity and hysteresis	$\pm 0,05\%$ typically, max. 0,25 % of end value
Start delay	5 s
Setting zero point	Via menu. Short-circuit mechanically both tube connectors P+ / P- for the moment of zero point setting
Stability	Long term stability < 0,2 %/year, temperature influence < 0,02 %/K, supply voltage influence < 0,01 %
Output	Voltage U [V] or current I [mA], selectable on site via menu, protected against short circuit and external voltage up to 24 V and against polarity reversal
Voltage output U	0...10 VDC adjustable, invertible, burden > 1 k Ω , influence < 0,05 %/100 Ω
Current output I	0...20 mA adjustable, invertible, burden < 500 Ω , influence < 0,1 %/100 Ω , open circuit voltage < 24 V
Output in alarm mode	Increasing or decreasing output signal, selectable on site, down to 0 VDC/0 mA or up to 10 VDC/20 mA
Wiring diagram	SB 1.0
Scope of delivery	Sensor, 3 self-tapping screws 4,2 x 13 mm resp. in stainless steel (with ...CT and ...VA versions), short circuit tube Cos-P...-A with 1 additional plug for cable \varnothing 6...8 mm
Parameter at delivery	min./max. pressure range limits (e.g. ExCos-P-100 = -100...+100 Pa), output 4...20 mA, output in alarm mode decreasing to 0 V/0 mA
...Cos-P...-A	as above and 1 additional intrinsically safe analogue output
Ex-i analogue output	(0)4...20 mA, intrinsically safe (IS), burden max. 400 Ω
Accuracy	$\pm 0,5\%$
Wiring diagram	SB 3.1

Approbations

ATEX directive	2014/34/EU
EC type-approved	EPS 14 ATEX 1 655 X
IECEx certified	IECEx EPS 14.0022X
Approval for gas	II 2 (1) G Ex e ma [ja Ga] IIC T6...T4 Gb Types ...-CT, ...-OCT II 2 (1) G Ex e ma [ja Ga] IIB T6 Gb
Approval for dust	II 2 (1) D Ex tb [ja Da] IIC T80°C...T130°C Db IP66
CE identification	CE № 0158
EMC directive	2014/30/EU
Enclosure protection	IP66 in acc. with EN 60529
EAC	TC RU C-DE.ГБ08.В.01510

Special solutions and accessories

...-CT	Types in aluminium housing with seawater resistant coating, parts nickel-plated
...-OCT	Offshore version in aluminium housing with seawater resistant coating, parts nickel-plated
...-VA	Types in stainless steel housing, parts nickel-plated
...-OVA	Offshore version in stainless steel housing, parts nickel-plated
EXC-RIA-16	LCD indicator (IS) for Ex-/RedCos... sensors in Ex-zones 1, 2, 21, 22
MKR	Mounting bracket for round ducts up to \varnothing 600 mm
Kit 2	Flexible pressure tube, 2 m, inner \varnothing 6 mm, 2 connection nipples
Kit-S8-CBR	2 cable glands M16 x 1,5 mm, Ex-e, brass nickel-plated, for cable \varnothing 5...10 mm
Kit-Offs-GL-CBR	2 cable glands M20 x 1,5 mm, Ex-d, Ms-Ni, for armoured cables
Kit-PTC-CBR	2 connecting tubes for tube fittings \varnothing 6 mm, stainless steel 316 L



Electrical connection

All sensors require a 24 VAC/DC power supply. The electrical wiring must be realized via the integrated Ex-e terminal box acc. to ATEX. The terminals' type of protection is "Increased safety Ex-e".

Attention: Before opening the terminal box cover, the supply voltage must be shut off! The supply has to be connected at terminals 1 (-/~) and 2 (+/~), the analogue output at terminals 3 (mA/V) and 4 (GND).

The optional analogue output at ...Cos-P...-A is intrinsically safe. Note the maximum connection values of intrinsically safe parameters (see table below).

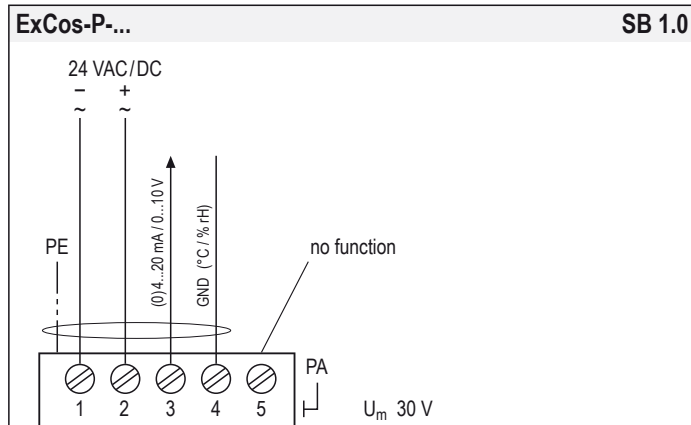

Intrinsically safe parameters (IS) – Internal pressure sensor

$U_o = 7.9 \text{ V}$	$C_i \rightarrow 0$		
$I_o = 48 \text{ mA}$	$L_i \rightarrow 0$		
$P_o = 95 \text{ mW}$			
		IIC	IIB
		L_o	10 mH
		C_o	$7.1 \mu\text{F}$

Internal sensor IS values are corresponding to the internal pressure sensor. Due to the matter of fact that there is no external sensor connected, these IS values are not relevant for the customer but shown for the sake of completeness.

Ex-i output (IS) (optional) – ExCos-P...-A

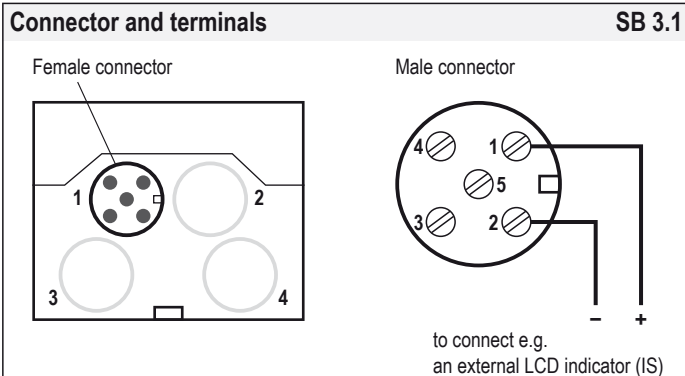

Intrinsically safe parameters (IS) – Analogue Ex-i output

$U_o = 15.8 \text{ V}$	$C_i \rightarrow 0$		
$I_o = 85 \text{ mA}$	$L_i \rightarrow 0$		
$P_o = 336 \text{ mW}$			
		IIC	IIB
		L_o	10 mH
		C_o	$1.8 \mu\text{F}$

Zero point compensation

...Cos-P... pressure sensors are equipped with a zero point compensation to adjust the module to the installation position. The pressure nipples P+ / P- must be connected with a short circuit tube and the zero point compensation performed by following the menu for parametrisation (menu 18).

Before starting the zero point compensation, the device should be connected to power supply for a minimum of 15 minutes to reach the uniform working temperature!

Display, buttons and parameters

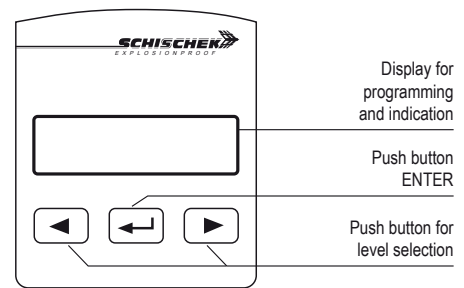

Change operation – parametrisation mode

To change from operation to parametrisation mode and vice versa, push ENTER button for minimum of 3 seconds. Back to operation mode with menu "save".

Indication of data logging

A flashing star in the display shows that data is received and the device is working.

Password input

The default/delivery setup is 0000. In this configuration the password input is not activated. To activate the password protection (menu 20) change the 4 digits into your chosen numbers (e.g. 1234) and press ENTER.

Please keep your password in mind for next parameter change! Due to a new parameter setup the password is requested.

Important information for installation and operation

A. Installation, commissioning, maintenance

All national and international standards, rules and regulations must be complied with. Certified apparatus must be installed in accordance with manufacturer instructions. If the equipment is used in a manner not specified by the manufacturer, the safety protection provided by the equipment may be impaired. For electrical installations design, selection and erection, EN/IEC 60079-14 can be used.

Attention: Apply all Ex rules and regulation before opening the internal terminal box. Do not open cover when circuits are live!

Draw the wiring cables through the cable glands. For connection use the internal Ex-e approved terminal box and connect equipotential bonding.

After connection install the cables in a fixed position and protect them against mechanical and thermal damage. Close all openings and ensure IP protection (min. IP66).

Avoid temperature transfer and ensure not to exceed max. ambient temperature! For outdoor installation a protective shield against sun, rain and snow should be applied.

After mounting and installation a zero point compensation must be done to ensure correct measurement results (see description).

Sensors are maintenance free. An annual inspection is recommended. For electrical installations inspection and maintenance, EN/IEC 60079-17 can be used.

Clean with damp cloth only.

Ex sensors must not be opened and repaired by the end user.

B. Long cabling

We recommend using shielded signal wires and to connect one end of the shield to the ...Cos... terminal box.

C. Separate ground wires

For supply and signal wires use separate grounds.



Parametrisation and commissioning

To change from operation to parametrisation mode push the "ENTER" button (↵) for minimum 3 seconds.
If password protected: type password and push (↵).
Back over to menu "Save" and exit.

Operation → Parametrisation
push (↵) for min. 3 s

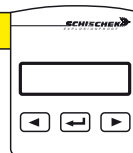

Example: Menu language English
Range -25...+25 Pa
Output 4...20 mA
Output Ex-i 0...20 mA

Menu	Function	ENTER	Indication	Select	ENTER	Next indication	Select	ENTER	Next menu
Menu 1	DE, EN, FR Select language: German, English, French	(↵)	DE, EN, FR English	(←) (→)	(↵)				(→)
Menu 2	no function – menu skip								
Menu 3	no function – menu skip								
Menu 4	Unit sensor Select physical unit	(↵)	unit sensor Pa	(←) (→)	(↵)				(→)
Menu 5	Range Adjust the measuring range	(↵)	range -25...100 Pa	(←) (→)	(↵)	range -25...25 Pa	(←) (→)	(↵)	(→)
Menu 6	no function – menu skip								
Menu 7	Output V, mA Select output signal as V or mA		output V/mA mA	(←) (→)	(↵)				(→)
Menu 8	Output range Adjust output range		output range 4...20 mA	(←) (→)	(↵)	output range 4...20 mA	(←) (→)	(↵)	(→)
Menu 9	Sensor error Select signal at sensor error		sensor error 10 V/20 mA	(←) (→)	(↵)				(→)
Menu 10	Output ↙↘ Select signal output behaviour		output ↙↘ increasing	(←) (→)	(↵)				(→)
Menu 11	no function – menu skip								
Menu 12	no function – menu skip								
Menu 13	no function – menu skip								
Menu 14	no function – menu skip								
Menu 15	no function – menu skip								
Menu 16	Output Ex-i (option, only at ...Cos-P...-A) Select lower output signal: 0 mA resp. 4 mA (0...20 or 4...20 mA)	(↵)	output Ex-i 0...20 mA	(←) (→)	(↵)	output Ex-i 0...20 mA	(←) (→)	(↵)	(→)
Menu 17	no function – menu skip								
Menu 18	Zero point compensation After short circuit the pressure nipples P+/P- the sensor gets a zero point calibration		set zero point yes no	(←) (→)	(↵)				(→)
Menu 19	Display function Select display settings	(↵)	display function on illuminated	(←) (→)	(↵)				(→)
Menu 20	Password Select password protection	(↵)	new password yes no	(←) (→)	(↵)	password 0000	(←) (→)	(↵)	(→)
Menu 21	Save and exit Select: save data, factory setting, discard or back to menu	(↵)	save and exit save data	(←) (→)	(↵)				(→)
Menu 22	Set offset Add/subtract offset from measure value	(↵)	set offset 0.00 Pa	(←) (→)	(↵)				(→)
Menu 23	no function – menu skip								
Menu 24	Attenuation Damping the output signal (signal filter)	(↵)	attenuation 0	(←) (→)	(↵)				(→)

TROX[®] TECHNİK

The art of handling air

TROX GmbH
Heinrich-Trox-Platz
47504 Neukirchen-Vluyn, Ger-
many

Germany
+49 (0) 2845 202-0
+49 (0) 2845 202-265
E-mail: trox@trox.de
www.trox.de

© TROX GmbH 2016