

Rotary heat exchanger for heat recovery



Tested to VDI 6022



Filter change



Water connections



Control system connection by others

Decentralised ventilation

SCHOOLAIR-D-HV



Supply and extract air unit with switchover option for secondary air operation, including rotary heat recovery unit and heat exchanger for installation below the ceiling

Ready-to-operate decentralised ventilation unit that provides good comfort levels and is used for the ventilation of internal spaces such as classrooms or conference rooms and day nurseries

- Freely suspended installation or partially or fully integrated in a suspended ceiling
- Acoustically optimised EC fans with low specific fan power, SFP = 0 to EN 16798-3
- Rotary heat recovery unit (75% heat recovery efficiency) with moisture recovery in winter
- Highly efficient heat exchanger for heating as a 2-pipe system
- Heat exchanger connection is on the right when seen from the room
- Heat recovery all year round
- Reduced fine dust and pollen contamination due to integral filters that conform to VDI 6022 – filter class ISO ePM1 60% and extract air ISO coarse 90%
- Easy filter change, no tools required
- Motorised shut-off dampers, normally closed (NC)
- Installation without interruption of school operations

Optional equipment and accessories

- Modular control system FSL-CONTROL III, specially for decentralised ventilation systems
- With electric air heater

Function	2	Order code	12
Function – Schematic illustration	3	Variants	14
Technical data	5	Dimensions	17
Quick sizing	5	Product details	19
Specification text	7		

Function

Functional description

Decentralised supply and extract air units ventilate the room and dissipate the heating load according to the technical data. An EC centrifugal fan takes in the fresh air which then flows through the motorised shut-off damper and the fresh air filter. The fresh air then flows through the rotary heat exchanger, which can be switched off when it is more energy-efficient. If necessary, the air is heated or (for change-over systems this is an option) by the heat exchanger before it is discharged through the supply air grille; the supply air first flows along the ceiling (Coanda effect) and creates no draughts. The extract air first passes through the outdoor air filter, then flows through the heat recovery unit, the extract air fan and the motorised shut-off damper before it is discharged to the outside as exhaust air. If the room air quality is sufficient, FSL-CONTROL III closes the outdoor air dampers and switches over to secondary air operation, which is more energy efficient in any case. The control system compares the setpoint

values of the indoor air quality with the CO₂ actual values measured with the CO₂ sensor and switches automatically between fresh air and secondary air operation. If the power fails, the fresh air and exhaust air dampers are closed to ensure fire protection and frost protection and to avoid draughts. This is ensured by a capacitor in each actuator. The supply air is discharged near the ceiling with a medium velocity. The Coanda effect deflects the air jet upwards, where it remains attached to the underside of the ceiling, thereby increasing the throw distance. Once it has reached the wall, which is located opposite the air outlet, an air curtain is created. The supply air reaching the occupied zone has a very low velocity and rises at heat sources (e.g. people and devices), thus giving rise to natural convection. As a result, the air is primarily exchanged in these areas. The stale air rises to the ceiling from where it is extracted and led outside.

Function – Schematic illustration

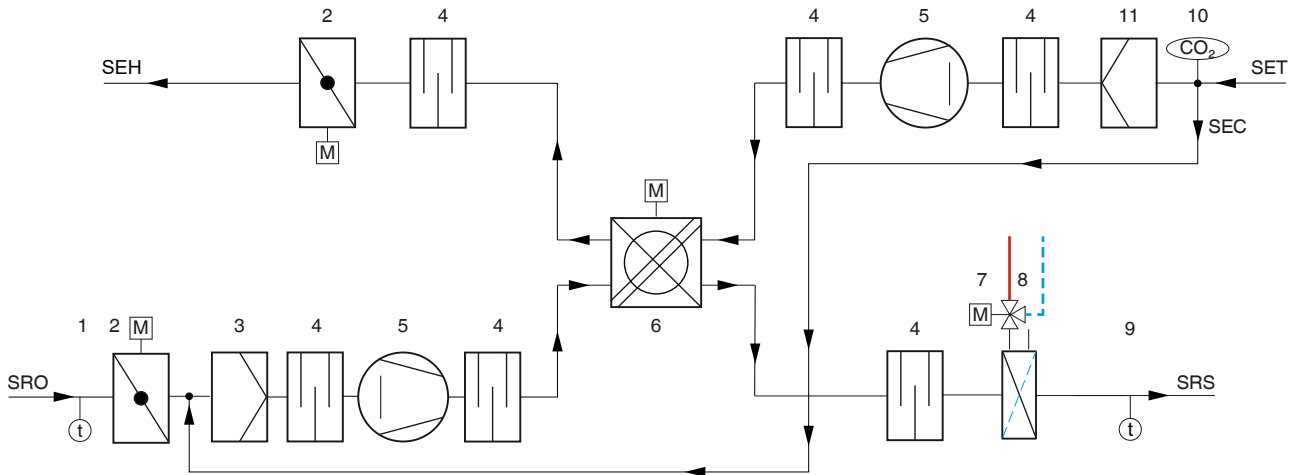

- SEH Single room exhaust air
- SET Single room extract air
- SRO Single room outdoor air
- SRS Single room supply air
- SEC secondary air (optional)
- 1 Outdoor air temperature sensor (optional)
- 2 Shut-off damper with actuator (outdoor air and exhaust air)
- 3 Outdoor air filter ISO ePM1 60%, with differential pressure monitoring
- 4 Sound attenuators
- 5 Fans (supply air and extract air)
- 6 Rotary heat exchanger for heat recovery
- 7 Heating coil
- 8 Cooling coil (only change-over system)
- 9 Supply air temperature sensor
- 10 CO2 sensor (optional)
- 11 Extract air filter ISO coarse 90%

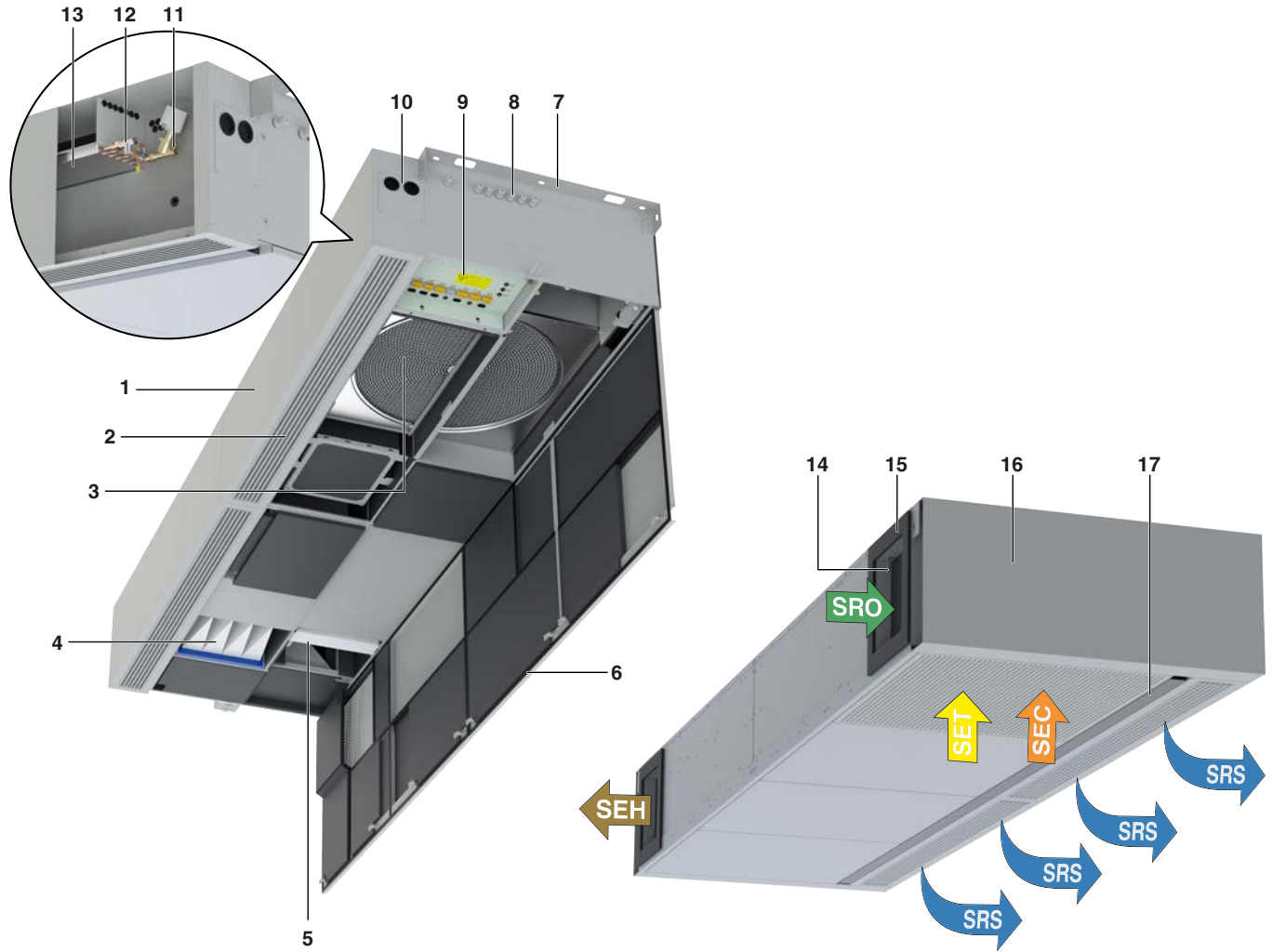

- SEH Single room exhaust air
- SET Single room extract air
- SRO Single room fresh air
- SRS Single room supply air
- SEC Secondary air (optional)

- 1 Casing
- 2 Supply air grille
- 3 Rotary heat recovery unit
- 4 Fresh air filter ISO ePM1 60 %
- 5 Extract air filter ISO Coarse 90 %
- 6 Inspection access panel (4 pieces)
- 7 Fixing bracket
- 8 Cable glands
- 9 Controls inspection access panel
- 10 Water connections
- 11 Valve (heat exchanger return)
- 12 Lockshield (heat exchanger flow)
- 13 2-pipe heat exchanger
- 14 Fresh air temperature sensor (optional)
- 15 Seal
- 16 Side cover (only installation situation -F)
- 17 Cover strips

Technical data

Width	3363 mm, 3555 mm, 3905 mm, 3900 mm
Height	410 mm, 440 mm
Depth	1030 mm, 1099 mm
Volume flow rate	300, 500, 800 m ³ /h (Boost 1100 m ³ /h)
Nominal volume flow rate	800 m ³ /h
Sound pressure level at nominal flow rate and 8 dB room attenuation	35 dB(A)
Sound power level	22 – 53 dB(A)
Heat recovery efficiency	75 %
Maximum operating pressure, water side	6 bar
Maximum operating temperature	75 °C
Supply voltage	230 V AC ±10 %, 50/60 Hz
Power rating	640 VA
Weight	340 kg

Quick sizing

SCHOOLAIR-D-HV (example of 2-pipe construction – active heating)

Supply air flow rate	m ³ /h	300	500	800	1100
Total heating capacity	W	2140	3600	5110	6040
Room heating capacity	W	1242	2104	2752	2829
Air temperature inside the unit	°C	12.8	12.8	12.8	12.8
Supply air temperature	°C	33.4	33.6	31.3	28.7
Hot water flow rate	l/h	60	120	180	200
Water temperature, inlet	°C	60	60	60	60
Water temperature, outlet	°C	29	33.9	35.3	33.8
Water side pressure drop	kPa	1.6	5.3	10.7	13
Sound power level L_{WA}	dB(A)	22	34	43	53
Sound pressure level with 8 dB system attenuation	dB(A)	14	26	35	45
Active power P_{el}	W	30	65	150	315

**SCHOOLAIR-D-HV (example 2-pipe construction – isothermal supply air)**

Supply air flow rate	m ³ /h	300	500	800	1100
Total heating capacity	W	1130	1830	2670	3390
Room heating capacity	W	230	351	294	147
Air temperature inside the unit	°C	12.5	12.5	12.5	12.5
Supply air temperature	°C	23.3	23.1	22.1	21.4
Hot water flow rate	l/h	30	55	90	125
Water temperature, inlet	°C	60	60	60	60
Water temperature, outlet	°C	27.4	31.1	34.2	36.4
Water side pressure drop	kPa	1.6	4.5	11	19
Sound power level L _{WA}	dB(A)	22	34	43	53
Sound pressure level with 8 dB system attenuation	dB(A)	14	26	35	45
Active power P _{el}	W	30	65	150	315

Specification text

This specification text describes the general properties of the product. Texts for variants can be generated with our Easy Product Finder design program.

SCHOOLAIR-D-HV-0-2/3355×405×1030/0/C3

School ventilation unit – ceiling installation

Ventilation unit for ceiling installation TROX SCHOOLAIR-V-HV with supply and extract air function, rotary heat recovery unit and switchover option to secondary air operation (air quality dependent) as well as heat exchanger for installation in the ceiling:

- One unit per room fulfils the increased fresh air requirements for a classroom
- Suitable for 4 different installation situations
 - Completely suspended ceiling, bottom edge of the ventilation unit flush with the suspended ceiling
 - Bulkhead (partially suspended ceiling), bottom edge of the ventilation unit flush with the bulkhead
 - Completely suspended ceiling, bottom edge of the ventilation unit not flush with the suspended ceiling (partially integrated)
 - Freely suspended unit
- 2-part device casing made of galvanised sheet steel, all necessary internal air duct sealed and lined, internal electrical cable penetrations sealed, exposed surfaces powder-coated (RAL 9010 GE 20 % – alternatively in RAL 7012 GE 20 %)
- Sound- and heat-insulating lining on intake and discharge sides made of mineral wool faced with glass fibre scrim (material classification A, non-combustible according to DIN 4102, T1), erosion resistant up to air velocities of 20 m/s, or closed cell insulation material
- The device meets the hygiene requirements of VDI 6022
- Interior fixing points for simple installation on the ceiling
- Connection to the outdoor air and exhaust air openings (provided by others) of the façade by means of perimeter closed-cell sealing tape on the rear side of the unit, $d = 10$ mm, the intake and discharge resistance of the construction provided by others should not exceed 20 Pa at a nominal volume flow rate, alternatively with duct connection
- Extract air intake opposite the supply air opening; extract grille is included
- Supply air is discharged on the underside of the ventilation unit through an innovative air terminal device that ensures complete ventilation of the room, whether it is installed at the front or at the opposite external wall
- To facilitate simple maintenance, the device covers have hinges on one side and are secured on the other side with fastenings with special locks. The area of the device must be completely accessible from underneath for maintenance work and possible disassembly
- Use of 2 plug fans with backward-curved blades, energy-saving EC technology, supply and extract air fans classified in category SFP 1 (< 500 W/(m³/s)) according to EN 16798-3:2017-11, a connected load of 600 VA must be taken into account for rating the connecting cable
- Suitable for 3 speed levels (300, 500 and 700 m³/h as well as boost level with 1050 m³/h), signalling via device-internal single room control system, volume flow rate level correction by adjusting the control voltage subsequently is possible
- Upstream and downstream sound attenuators for maximum reduction of the sound power level
- The technical requirements of EU directive 1253/2014 for non-residential ventilation systems are fulfilled and documented in accordance with the directive
- Integral rotary heat exchanger for heat recovery with high efficiency (heat recovery efficiency >75 %), modulating control by device-internal single room control system
- Motorised shut-off dampers in the outdoor/exhaust air area, normally closed when there is no power by means of energy storage, actuator 230 V, open/close, signalling via device-internal single room control system
- Automatic switching to secondary air mode (only with an air quality sensor) if the indoor air quality (measured, for example, with the integral CO₂ sensor) lies within the limits defined beforehand. The fresh air damper closes, the self-powered secondary air damper opens and the extract air fan is switched off.
- Electrical components contained in the unit are completely wired with FSL-CONTROL III, control components are integrated in the unit. Cable for connection (connection not supplied by TROX) of the power supply (L, N, PE) with wire end ferrules led approx. 1 m out of the unit: As a transfer point to the electrical installation provided by others:
 - Supply voltage (230 V): 3 wires, 3×1.5 mm² (L, N, PE)
- Connection possibility for bus communication (optional), connection of control panel, etc. after opening the customer area of the controls. As a transfer point to the controls provided by others:
 - Rail mount terminals type Wago 260 for the connection (provided by others) of
 - Digital inputs DI
 - Digital outputs DO
 - Master-slave connection RS485
 - BMS connection (optional) RS485
 - Control panel
 - RJ45 socket as service access to the user interface
- The following sensors are arranged in the unit to control the single room control system (the actual room temperature is recorded at the control panel):
 - Indoor air quality sensor CO₂
 - Supply air temperature measurement downstream of the heat exchanger

- Outdoor air temperature measurement in the outdoor air intake
- 2-pipe aluminium copper tube heat exchanger for air heating, matched to project-specific data, easily removable for cleaning (depends on the connection to the main pipe - by others, not included in the TROX supply package), venting option per heating circuit. We recommend a connection to the pipe network (provided by others) with flexible hoses (not included in the TROX supply package) so that the heat exchanger can be easily removed for cleaning
- Transfer points are the manually preassembled control components
 - Valve in the return: transfer with G ½" external thread, flat seal
 - Lockshield in the flow: transfer with G ½" external thread, flat seal
 - Fresh air filter as a pocket filter with non-woven glass fibres, ISO ePM1 (fine dust filter):
- Filter class to ISO16890: ISO ePM1 60 %
 - Eurovent certification for fine dust filters
 - Meets the hygiene requirements of VDI 6022
 - High energy efficiency class according to Eurovent
 - Non-woven glass fibres, sewn
 - Enlarged filter area due to filter pockets
 - Low initial differential pressure and high dust holding capacity, ideal flow conditions due to wedge-shaped filter pockets
 - Quick installation and filter changing times due to easy, safe handling
 - Filter area $\geq 1.4 \text{ m}^2$
- Extract air filter with large filter area due to pleats
 - Filter class to ISO16890: ISO Coarse 90 %
 - Low differential pressures at high volume flow rates
 - Filter media made of synthetic fibres
 - Moisture-resistant, frame made of non-woven fibres
 - Tested to ISO 16890
- Quick change of filters is possible, as the filter insert can be accessed once the cover part has been opened
- Differential pressure measurement allows for filter monitoring, evaluation via integral single room control system

Units – dimensions and weight

- Width: approx. 3355 mm (without fixing bracket)
- Width: approx. 3555 mm (freely suspended version with side covers)
- Height: approx. 405 mm
- Depth: approx. 1030 mm (without façade sealing)
- Approx. 340 kg

FSL-CONTROL III Regler

Including control system FSL-CONTROL III, as described below: FSL-CONTROL III is described as stand-alone single room control equipment with a simple timer. Optional expansions, such as connection to the central BMS provided by others via Modbus TCP / Modbus RTU, BACnet MS/TP or BACnet IP, humidity sensors, return flow temperature sensors, electromotive valve actuators or pressure-independent control valves are included in the product range, but must be replaced with the standard components in the following description. A room temperature signal is also required. Various room control panels and sensors are available for this purpose. The corresponding optional equipment text modules can be found in the appendix of

the following standard equipment for room-autonomous operation. We recommend commissioning by our technical service. You will find related text modules below.

TROX control module FSL-CONTROL III (order code ...-C3-MA ...):

- Single room controller for mounting on DIN mounting rail in the unit or in a separate control casing
- 42 digital or analogue inputs and outputs
- MicroSD card (at least 2 GB) as integral flash memory. The trend data is stored here and can be accessed via the RJ45 service socket.
- Equipped at the factory with a software package for master units specially developed for decentralised ventilation units. The software enables simple master-slave communication via Modbus RTU
- Up to 10 slave devices can be connected to one master device
- The software provides 3 types of operation (Off, Automatic and Manual), 3 operating modes (Occupied, Unoccupied and Standby) and 4 operating mode overrides (Boost, Class, Night Ventilation and Fan Forced Circuit)
- Basic distinction between room temperature control by controlling heating and cooling valves or modulating bypass damper or supply air temperature control for isothermal ventilation
- CO₂-guided air quality control
- Year-round heat recovery use
- Filter monitoring
- Configurable DI, e.g. for connection (by others) of PIR sensors, window contacts, holiday switching, etc.
- Alarm signals type A (= switch-offs) and type B (= notifications)

Real time clock (RTC)

Real Time Clock (RTC/real time clock) (order code ...-T/...):

- Component of the Master Software Package
- Enables a simple timer
 - 7 days with 10 switching points each
 - Automatic summer / winter time changeover
 - Temporal activation of night purge

CO₂ sensor

CO₂ sensor (order code .../C/...):

- Sensor arranged in the extract air intake of the master unit for recording the indoor air quality and corresponding control of the outdoor air flow rate
- Measurement via an NDIR sensor, which works on an infrared basis and compensates for any contamination by its 2-beam measurement principle
- Measuring range 0 – 2000 ppm

Supply air temperature sensor

Supply air temperature sensor (order code .../Z/...):

- Supply air temperature sensor with NTC thermistor as sensing element, resistance 10 kΩ at 25 °C, measuring range 0 – 50 °C
- Especially fast response time due to perforated measuring tip

Fresh air temperature sensor

Outdoor air temperature sensor (order code .../A/...):

- Outdoor air temperature sensor with NTC thermistor as sensing element, resistance 10 kΩ at 25 °C, measuring range -30 – 50 °C

Water side components

Water-side components (order code .../HV-R-.../KV-R-...):

- Valve actuator: 1 × thermoelectric actuator for opening and closing valves, with position indicator, including pluggable connecting cable, supply voltage 24 V DC, control voltage 0 – 10 V DC, power consumption 1 W, degree of protection: IP 54
- Straight-way valve: 1 × straight-way valve ½", mounted (finger-tight), PN 16, DN10, K_{vs} 0.4 (alternatively: 0.25, 0.63 or 1.0 m³/h – please specify the required K_{vs} value), threaded connection G 1/2B, fluid temperature 1 to 110 °C
- Lockshield: 1x lockshield on both sides ½", mounted (finger-tight), nominal width DN 15; ½", straight through valve with male thread on both sides, flat sealing, for control and shut-off, operating temperature 120 °C max.

Optional control accessories

Optional equipment to increase the comfort of the FSL-CONTROL III:

TROX control panels for FSL-CONTROL III

At least one room temperature signal is required per room.

There are several variants of TROX control panels available, optionally with or without step switching. Additionally we offer a room temperature sensor RTF without control elements.

Alternative control panels provided by the customer must be connected via bus communication:

Digital control panels for surface mounting

For the operation and adjustment of the ventilation units.

- Supplied loose as an accessory. Connection to master unit via Modbus serial line. Project-specific software including setpoint value adjuster, various status displays, selector switch, CO₂ traffic light. Touch-sensitive colour display 3.5" 320 × 240 pixels. Sensor: NTC 10 kΩ. Degree of protection: IP 20. Type: Schneider TM172DCLWT. Dimensions (H × B × T): 120 × 86 × 25 mm, weight: 340 g, colour: white. Installation: wall mounting or on standard flush box. Supply: 24 V DC. Power consumption: 3.2 VA/1.3 W. Optional further design frames available for a surcharge on request.

Control panels with selector switch for surface mounting:

Control panel with selector switch, for surface mounting, type Honeywell

- Supplied loose as accessory, with room temperature sensor, setpoint adjuster (blue or white), override button, LED and 3-step switch as well as off and automatic, assembly on 60 mm flush box or directly on the wall, NTC thermistor as sensor element, resistance 20 kΩ at 25 °C, dimensions (B × H × T): 99 × 104 × 30 mm, operating temperature: 6 - 40 °C

Control panel with selector switch, for surface mounting, type Thermokon

- Supplied loose as an accessory, with room temperature sensor, setpoint adjuster (blue or white), override button, LED and 3-step switch as well as off and automatic, casing made from pure white PVC0 (RAL 9010) assembly on 60 mm

flush box or directly on the wall, NTC thermistor as sensor element, resistance 20 kΩ at 25 °C, dimensions (B × H × T): 84.5 × 84.5 × 25 mm, operating temperature: -35 – 70 °C

Control panels without selector switch for surface mounting:

Control panel without selector switch, for surface mounting, type Schneider

- Supplied loose as additional part, with mode display, push button and setpoint adjustment, sensor NTC 10 kΩ, protection level: IP 20, wall mounting or on 70 mm flush-mounted box, dimensions (B × H × T) 84 × 116 × 24 mm, colour light grey/white

Control panel without selector switch, for surface mounting, type Thermokon

- Supplied loose as additional part, with mode display, push button and setpoint adjustment, sensor NTC 20 kΩ, protection level: IP 20, dimensions (B × H × T) 84.5 × 84.5 × 25 mm

Room temperature sensor for surface mounting:

Room temperature sensor TROX RTF, surface mounting

- Supplied loose as additional part, room sensor without control elements, measuring range: -35...70°C, sensor NTC 10 kΩ, screw terminal, d=1.5 mm, protection level IP 20, assembly wall mounted or on 70 mm flush-mounted box, dimensions (B × H × T) 85 × 85 × 30 mm, casing ABS in RAL 9010

Control panels without selector switch for flush mounting:

For manual operation of the ventilation units with a high-quality look and the matching design frame from a wide range of switch programmes, the unit is suitable for particularly design-oriented facilities.

Control panel without selector switch, for flush mounting, type Thermokon, switch from Berker S.1 range, polar white

- Supplied loose as additional part, with mode display, push button and setpoint adjustment, sensor NTC 20 kΩ, protection level: IP 20

Control panel without selector switch, for flush mounting, type Thermokon, switch from Berker Q.3 range, white

- Supplied loose as additional part, with mode display, push button and setpoint adjustment, sensor NTC 20 kΩ, protection level: IP 20

Control panel without selector switch, for flush mounting, type Thermokon, switch from Busch-Jäger future range® linear, white

- Supplied loose as additional part, with mode display, push button and setpoint adjustment, sensor NTC 20 kΩ, protection level: IP 20

Further switch programmes on request.

Control panels without selector switch and without setpoint value adjuster for flush mounting:

Control panel without selector switch and without setpoint value adjuster, for flush mounting, type Thermokon, switch from Gira E2 range

- Supplied loose as additional part, with mode display and button, sensor NTC 20 kΩ, protection level: IP 20

Further switch programmes on request

Electromotive valve actuator:

As an alternative to the standard installed thermoelectric actuator

- 1 x electromotive actuator for opening and closing valves, supply voltage AC/DC 24 V, maximum power consumption 2.5 VA, signalling of control signal 3-point DC 0...10 V, permissible operating fluid temperature 1...110 °C

Pressure-independent control valve:

As an alternative to the standard installed straight-way small valve

- 1 x pressure-independent control valve, manually pre-assembled with modulating open and close control in combination with an externally adjustable dynamic volume flow controller, with full valve authority, nominal width DN 10, ½", valve casing straight through with male thread on both ends, flat seal, fluid temperature 0 – 120 °C

Interface for connection to central building management system (BMS) provided by others: Modbus TCP interface including web server (order code .../MT/...)

To increase comfort, we recommend integration into a central building management system provided by others. FSL-CONTROL III offers the possibility to be connected to a central BMS provided by others using Modbus TCP protocol. Additionally incl. web server for simplified configuration, commissioning and remote monitoring of the device. The central BMS is not included in the supply package from TROX, only the interfaces listed above are available here.

- Modbus TCP interface (Ethernet)

BACnet IP interface including web server (order code .../BI/...)

To increase comfort, we recommend integration into a central building management system provided by others. FSL-CONTROL III offers the possibility to be connected to a central BMS provided by others using BACnet IP protocol. Additionally incl. web server for simplified configuration, commissioning and remote monitoring of the device. The central BMS is not included in the supply package from TROX, only the interfaces listed above are available here.

- BACnet IP interface (Ethernet)

Modbus RTU (order code .../MR/...)

To increase comfort, we recommend integration into a central building management system provided by others. FSL-CONTROL III offers the possibility to be connected to a central BMS provided by others using Modbus RTU protocol. The central BMS is not included in the supply package from TROX, only the interfaces listed above are available here.

- Modbus RTU interface (RS485)

BACnet MS/TP (order code .../BM/...)

To increase comfort, we recommend integration into a central building management system provided by others. FSL-CONTROL III offers the possibility to be connected to a central BMS provided by others using BACnet MS/TP. The central BMS is not included in the supply package from TROX, only the interfaces listed above are available here.

- BACnet MS/TP interface (RS485)

Commissioning of the decentralised ventilation units

Commissioning / parameter setting of decentralised ventilation units without connection to the central building management system

- Visual inspection of the unit connections carried out by others for compliance with the respective installation specifications from the installation and configuration instructions: air connections, heating/cooling connection, electrical connections, integration into the installed outer casing, connections of external components
- Checking and, if necessary, adapting the project parameters pre-set in the factory with regard to customer-specific adaptations
- Functional test of the individual components (control elements, fans, valves, dampers, sensors)
- Checking the project-specific control functions including any special functions such as volt-free switch contacts
- Documentation of the device settings as well as their use in a service report. The service report must be signed by your company as the customer or your representative
- The invoice is made as a flat rate, derived from the number of devices and distance

Commissioning / parameter setting of decentralised ventilation units with connection to the central building management system

- Visual inspection of the unit connections carried out by others for compliance with the respective installation specifications from the installation and configuration instructions: air connections, heating/cooling connection, electrical connections, integration into the installed outer casing, connections of external components, central building management system connections
- Checking and, if necessary, adapting the project parameters pre-set in the factory with regard to customer-specific adaptations
- Functional test of the individual components (control elements, fans, valves, dampers, sensors)
- Checking the project-specific control functions including any special functions such as volt-free switch contacts
- Function test of the communication to the central BMS in cooperation with the ordered controls company:
 - Checking that the settings that are provided by others comply with the specifications in the installation and configuration instructions
 - Input test of the data points sent by the customer
 - Output test of the output data points
 - Trial operation of the operating conditions switchable by the central BMS
- Documentation of the device settings as well as their use in a service report. The service report must be signed by your company as the customer or your representative
- The invoice is made as a flat rate, derived from the number of devices and distance

Instruction in operation and maintenance

- One-off instruction for the operation of the decentralised ventilation units consisting of:
 - Description of the equipment functions on the unit that has already been put into operation
 - Description of the room control panel and the room conditions that can be influenced by it



- Description of maintenance work
- The invoice is a flat rate and is carried out by the responsible sales representative

Order code

SCHOOLAIR-D – 0 – 0 – 4 – 0 / 1640 × 400 × 800 / 0 / C3 / MA – T / MR / C / Z / A / HV – R – 0,4 / KV – R – 0.4
 1 2 3 4 5 6 7 8 9 10 11 12 13 14 15 16 17 18 19 20

1 Type

SCHOOLAIR-D-HV Ventilation unit for ceiling installation

2 Variant

No entry required: Standard

HV High volume flow rate and rotary heat recovery unit

3 Installation situation

0 Installation integrated in suspended ceiling

F freely suspended installation (SCHOOLAIR-D-HV only)

T partially integrated in suspended ceiling (SCHOOLAIR-D-HV only)

Z Installation in a pre-assembled frame (SCHOOLAIR-D-HV only)

4 Heat exchanger

2 2-pipe

4 4-pipe (only SCHOOLAIR-D-0)

EH with electric air heater (SCHOOLAIR-D-HV only)

5 Construction (SCHOOLAIR-D-HV only)

0 without duct connection

B with 2 × raised edges on the back of the unit (DN 315)

KL With duct connection on the left when seen from the room (270 × 270 mm) and raised edges rear (DN 315)

KR With duct connection on the right when seen from the room (270 × 270 mm) and raised edges rear (DN 315)

KLR With duct connection on the left when seen from the room (270 × 270 mm) and on the right when seen from the room (270 × 270 mm)

6 Dimensions [mm]

B × H × T

1640 × 400 × 800 (2-pipe)

1640 × 400 × 800 (4-pipe)

3363 × 410 × 1030 (HV version integrated into the ceiling)

3555 × 410 × 1030 (HV version freely suspended)

3905 × 410 × 1030 (HV version partially integrated in suspended ceiling or construction with duct connection for freely suspended installation)

3900 × 440 × 1099 (HV version frame assembly)

7 Exposed surface

0 RAL 9010 (GU30)

P1 RAL 7012 (GU 30), alternatively any other RAL CLASSIC colour (GU 30)

8 Control

OR Without control

C3 With FSL-CONTROL III

9 Control function

MA Master

SL Slave

10 Real-time clock, only master

No entry: None

T With

11 Interface

No entry: None

MT With Modbus TCP

MR With Modbus RTU

BI With BACnet IP

BM With BACnet MS/TP

12 Air quality sensor, only master

No entry: None

C With CO₂ sensor

V With VOC sensor

13 Supply air temperature sensor

Z With

14 Outdoor air temperature sensor, only master

No entry: None

A With

15 Heating valve

HV With

16 Lockshield heating circuit

R With

17 K_{vs} value – heating valve

0.25 Straight-way valve

0.40 Straight-way valve

0.63 Straight-way valve

1.00 Straight-way valve

F0.50 Pressure-independent control valve

18 Cooling valve (only SCHOOLAIR-D-0)

Only 4-pipe systems

KV With

19 Lockshield cooling circuit (only SCHOOLAIR-D-0)

R With

20 K_{vs} value – cooling valve (only SCHOOLAIR-D-0)

0.25 Straight-way valve

0.40 Straight-way valve

0.63 Straight-way valve

1.00 Straight-way valve

F0.50 Pressure-independent control valve

Order example: SCHOOLAIR-D-HV-0-2-KL/3363×410×1030/0/C3-MA-T/C/Z/A/HV-R-0.40

SCHOOLAIR-D	Ventilation unit for ceiling installation
HV	High volume flow rate and rotary heat recovery unit
0	Installation integrated in suspended ceiling
2	With 2-pipe heat exchanger
KL	With duct connection on the left when seen from the room
0	RAL 9010 (GU 30 %)
C3	With FSL-CONTROL III
MA	Master construction
T	With real time clock
C	With CO ₂ sensor
Z	With supply air temperature sensor
A	With outdoor air temperature sensor
HV-R-0.40	With straight-way valve (heating circuit) kvs 0.40 and lockshield

Order example: SCHOOLAIR-D-HV-F-2/3555×405×1030/0/C3-SL-Z/HV-R-0.40

SCHOOLAIR-D	Ventilation unit for ceiling installation
HV	High volume flow rate and rotary heat recovery unit
F	Freely suspended installation
2	With 2-pipe heat exchanger
0	RAL 9010 (GU 20 %)
C3	With FSL-CONTROL III
SL	Slave construction
Z	With supply air temperature sensor
HV-R-0.40	With straight-way valve (heating circuit) kvs 0.40 and lockshield

Order example: SCHOOLAIR-D-HV-0-2/3363×410×1030/P1-RAL 7012/C3-MA-MT/C/Z/HV-R-F0.50

SCHOOLAIR-D	Ventilation unit for ceiling installation
HV	High volume flow rate and rotary heat recovery unit
0	Installation in suspended ceiling
2	With 2-pipe heat exchanger
P1	RAL 7012 (GU 20 %)
C3	With FSL-CONTROL III
MA	Master construction
MT	With Modbus TCP interface
C	With CO ₂ sensor
Z	With supply air temperature sensor
HV-R-F0.50	With pressure independent control valve (heating circuit) and lockshield

Variants

SCHOOLAIR-D-HV-0, for flush ceiling installation



Special features

- Suitable for suspended ceiling installation with the bottom edge of the ventilation unit flush with the suspended ceiling
- Factory mounted L bracket at the side makes fixing the unit to the ceiling construction easy (fixing by others)
- Some constructions (B, KL, KR and KLR - see order code) facilitate connection to the ductwork (by others)
- Dimensions: 3363 × 410 × 1030 mm

SCHOOLAIR-D-HV-F, for freely suspended installation

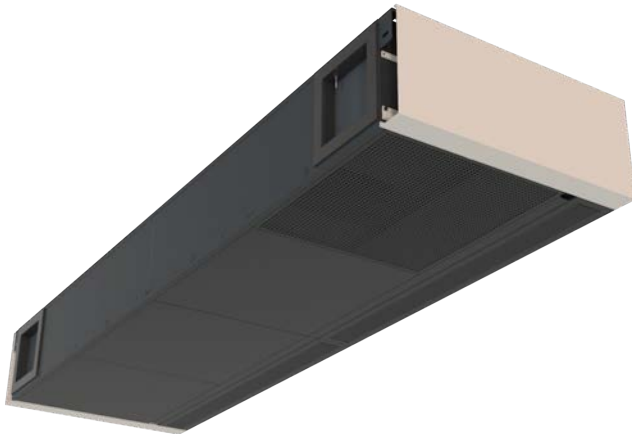

Special features

- Suitable for freely suspended installation
- Cover plates can be slid in from the front, no tools required
- Panels on the side provide access to fixing points, water connections and electrics
- Some constructions (B - see order code) facilitate connection to the ductwork (by others)
- Dimensions: 3555 × 410 × 1030 mm

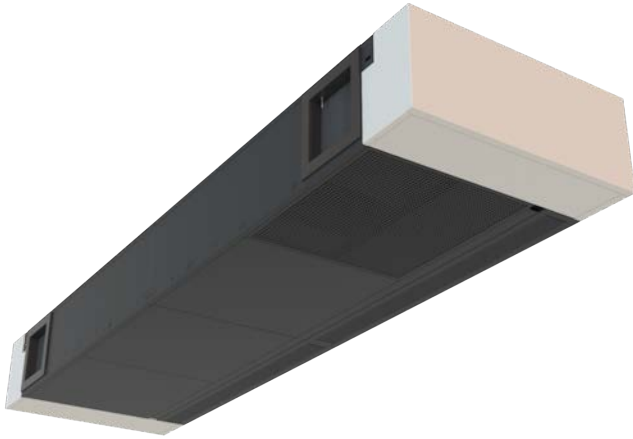
SCHOOLAIR-D-HV-T, for partially integrated ceiling installation**Special features**

- Suitable for partial integration into a suspended ceiling
- Cover plates on the underside can be opened, no tools required
- Panels on the side provide access to fixing points, water connections and electrics
- This variant is also suitable for freely suspended installation with duct connection (see order code, constructions B, KL, KR and KLR)
- Dimensions: 3905 × 410 × 1030 mm

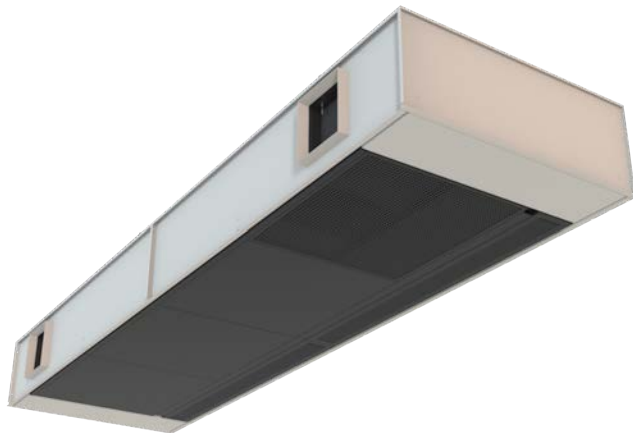
Construction Z: consists of two parts, i.e. frame and ventilation unit**Special features**

- Suitable for installation into a frame that is to be installed beforehand in a suspended ceiling
- The frame will be delivered and installed in advance. Any jobs required on site by others (e.g. outdoor and exhaust air connections, preparing water and electricity connections) can be carried out before the unit itself is delivered. The ventilation unit can be installed in the frame at a later stage.
- The unit can be connected to existing ducts (see order code, constructions B, KL, KR and KLR)
- Dimensions: 3900 × 440 × 1099 mm

SCHOOLAIR-D-HV, colour variant

- Alternatively, surface coated RAL 7012, GU30

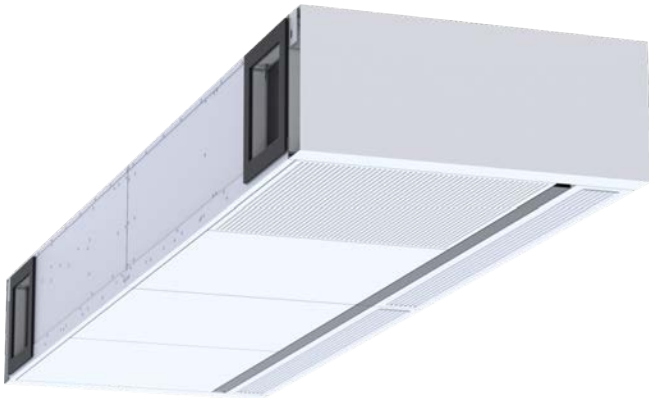
SCHOOLAIR-D-HV, colour variant

- Surface coated RAL 9010, GU30, with cover strips coated RAL 7012, GU30

SCHOOLAIR-D-HV, colour variant

- Alternatively, surface coated RAL 7012, GU30, with cover strips coated RAL 9010, GU30

Construction T: for partially integrated ceiling installation



Construction Z: consists of two parts, i.e. frame and ventilation unit

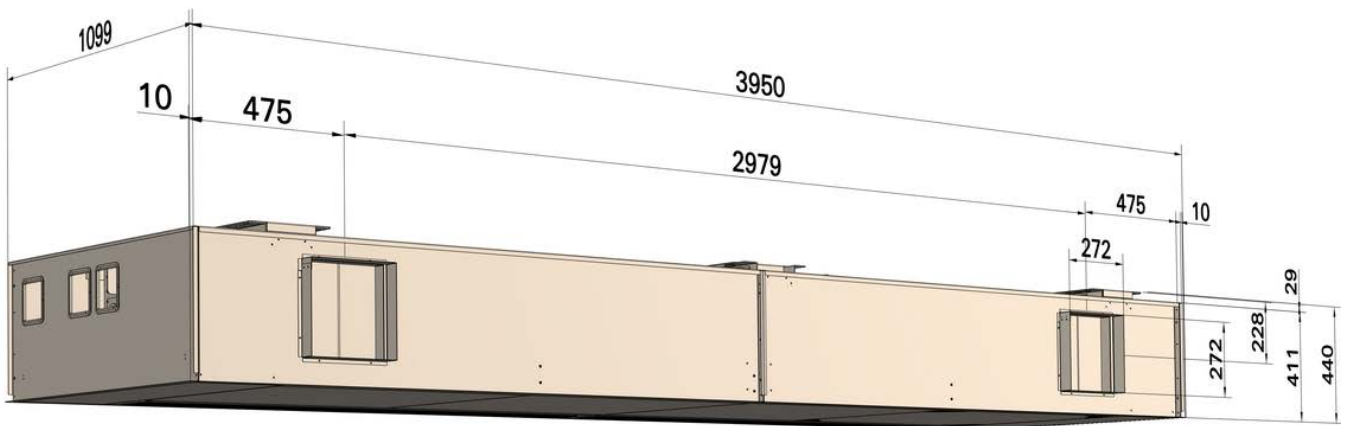

Product details



- Installation below the ceiling slab and near an external wall
- 2-part device casing for easier transport and simple installation
- The ventilation unit is fitted with 2 hanging brackets to screw-fix it to the façade system or an external wall
- Weather protection for the fresh air and exhaust air openings to be provided by others
- The fresh air connection is provided by 2 ventilation openings (by others) in the façade system or external wall; the openings should preferably be sloping towards the outside
- Free area of ventilation openings: 0.10 m² for each opening
- Installation and connections to be performed by others; fixing, connection and sealing material to be provided by others
- The water flow and return connections are on the right-hand side of the unit when seen from the room
- Vents and drainage by others
- The electrical connection is on the right-hand side of the unit when seen from the room