

Installation Instructions

Connecting hoses Type FS

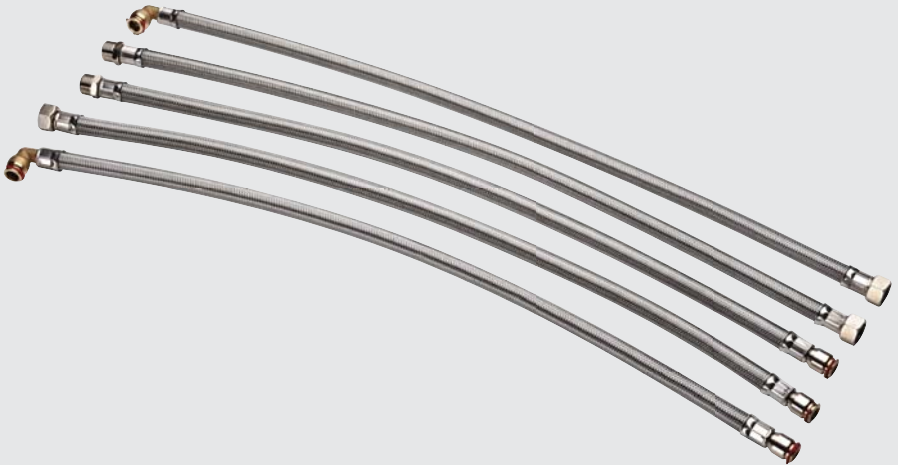

TROX[®] TECHNIK

The art of handling air

1	General information	2
	Symbols used in this manual	2
2	Correct use	3
	Correct use	3
	Incorrect use	3
	Acceptable media	3
3	Technical data	3
4	Installation	4
	Hose laying	4
	General information	5
	Fittings	6
	External threads and union nuts	7
5	Removal	8
	Fittings	8
	Screw joints	8

These instructions describe the installation of the type FS connecting hoses.

Connecting hoses that are oxygen diffusion tight (to DIN 4726) enable a simple, quick water-side connection between the TROX components and the on-site pipe system.

Symbols used in this manual



Important

Designates danger that can cause minor personal injury or damage to property.



Protective gloves

Wear protective gloves to avoid injuries.

TROX[®] TECHNİK

TROX GmbH

Heinrich-Trox-Platz
47504 Neukirchen-Vluyn, Germany

Phone +49(0)2845 2020
Fax +49(0)2845 202265

E-mail trox@trox.de
www.troxtechnik.com

Part No. A00000036075
Subject to change. /

All rights reserved © TROX GmbH

2 Correct use

Correct use

- The connecting hoses are suitable for all TROX air conditioning components, such as chilled ceilings, passive chilled beams, induction units and decentralised ventilation units.
- The connecting hose serves as a flexible, water-side connection between the heat exchanger and the on-site pipe system consisting of copper pipes according to EN 1057 used for heating and/or cooling.
- Connecting hoses let you remove or swivel out the heat exchangers for cleaning and maintenance without having to empty the system.

Incorrect use

- Tensioning the hose
- Kinking the hose or using a bend radius that is too small
- Laying the hose along sharp edges
- For unacceptable operating pressures or operating temperatures, and for acceptable pressures and temperatures, see Technical data.

Acceptable media

To fill the system, use clean tap water (pH value 6.5 to 9.5) or a water-glycol mixture (max. 30% glycol).

3 Technical data

Minimum bend radius

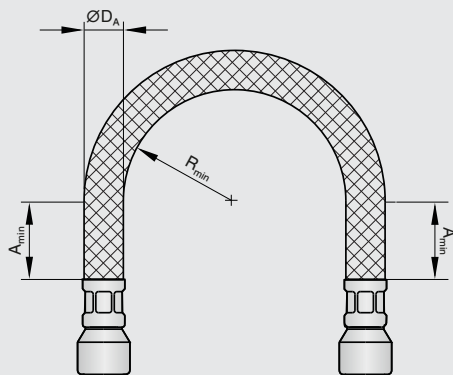

Dimensions [mm]

Nominal width	$\varnothing D_A$	A_{min}	R_{min}
10	12.5	12.5	62.5
13	17	17	85

Technical data

Operating pressure	6 bars max.
Media temperature	-20 °C to + 55 °C

4 Installation

Hose laying

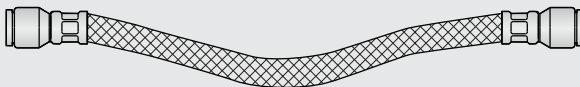
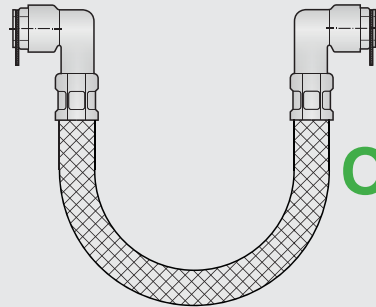
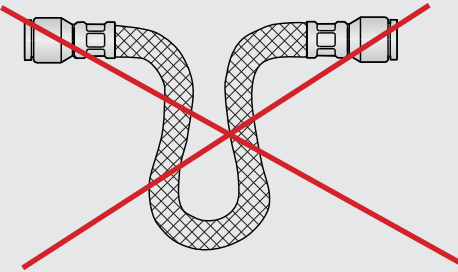
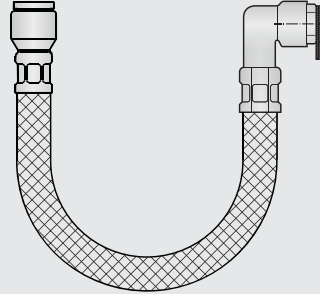
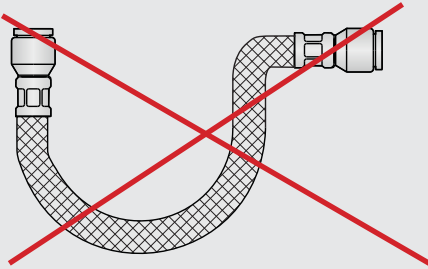
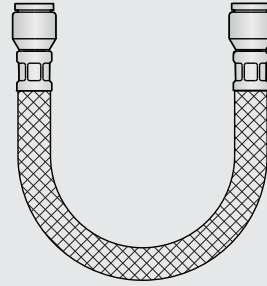
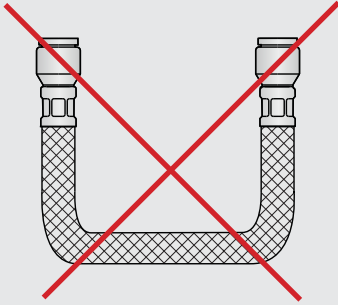

4 Installation

General information



Important

When working on hot water systems, there is a danger of burns. Before starting to work, shut down the heating circuit and leave it to cool down.



Important

Before starting the installation, block off and drain the water and/or water-glycol circuit.



Protective gloves

Wear protective gloves for all work.

Preparations

- Cut pipes at a right angle to the centre line. ①
- When using a pipe cutter, make sure that the disc blades are sharp; advance the cutter only slowly.
- Deburr the pipe ends afterwards on the inside and outside. ②
- Before installing the hose, remove any protective caps.
- If the hose is used to make a connection to swivel-out or removable components, be sure to use a sufficiently long hose to avoid kinking.

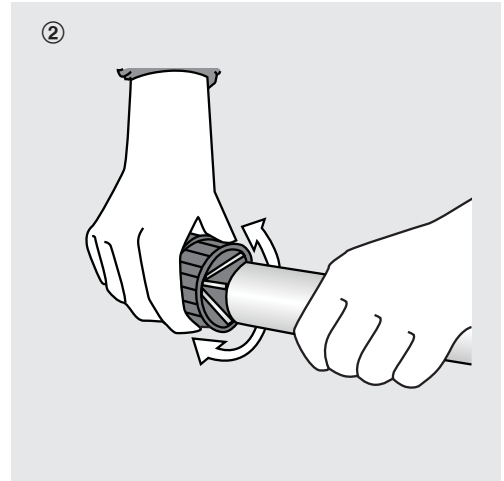
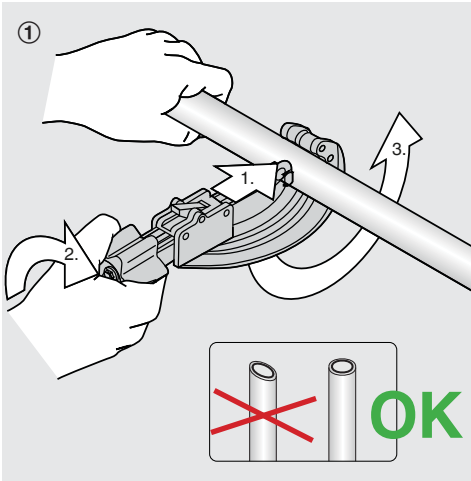

4 Installation

Fittings

Fittings

- Deformed pipe ends or those which are not perfectly circular must be calibrated with a calibration ring and mandrel before the fittings are used.
- Mark the plug-in depth (~ 22 mm) on the pipe. ③
- Insert the circlip (red) during installation, if possible, or before commissioning at the latest.
- Avoid tilting the fittings when placing them on the pipe.
- Push the fittings on up to the travel stop.
- To check the secure seat of the fitting, i.e. the locking of the claw, pull the mounted fitting into the removal direction.

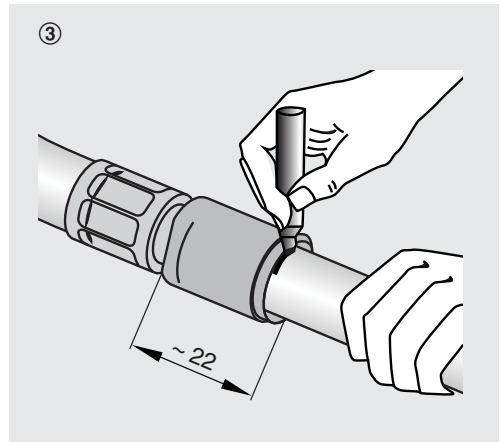

Construction variants

- ① SG 10 / SG 12, fitting, straight
- ② SW 10 / SW 12, fitting 90°

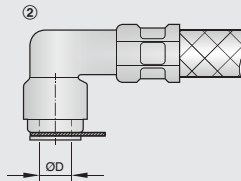
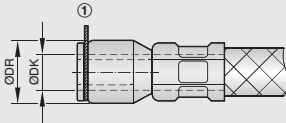

Installation of the push-on fittings

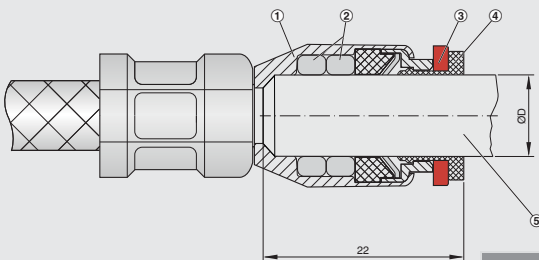

- ① Fitting
- ② Ring seal
- ③ Circlip
- ④ Opening ring
- ⑤ Pipe

Dimensions [mm]

Hose	Connection		
	Ø D	Ø DK	Ø DR
DN 10	10	6.6	17.5
DN 13	12	10	19.7

4 Installation

External threads and union nuts

Construction variants

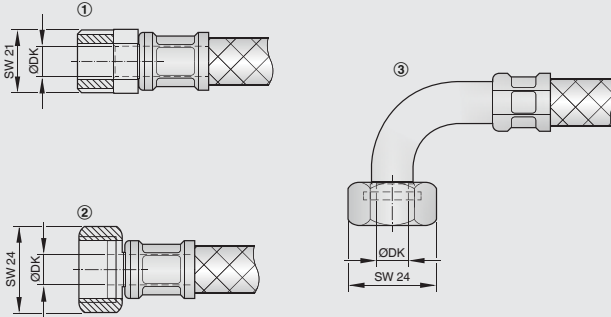

- ① G1/2" external thread, flat end seal
- ② G1/2" internal thread, union nut, flat end seal
- ③ G1/2" internal thread, union nut 90°, flat end seal

External threads and union nuts

- Sealing surfaces must be free of contamination.
- Check the seal for secure fit.
- Tighten the external thread and the nuts only hand-tight at first.
- Use suitable spanners to tighten the hand-tight screw joints.
- G1/2" external thread, 21 mm
- G1/2" union nut, 24 mm
- When tightening the screw joint, use a second spanner to lock it ④ and to prevent damage to the heat exchanger or pipe.

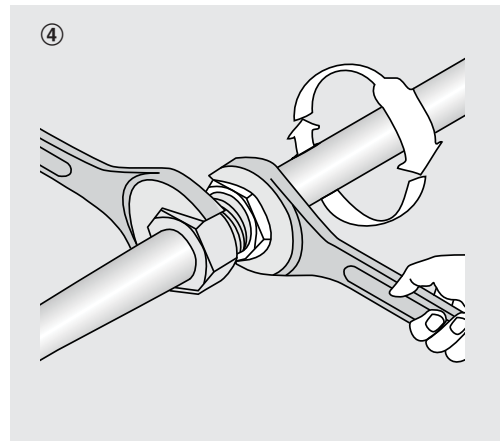

5 Removal

Fittings

- Remove the circlip (red).
- Press the opening ring against the fitting to loosen the claw; then remove the fitting.

Screw joints

Screw joints can be loosened using a suitable tool. When loosening the screw joint on the heat exchanger and pipe, use a second spanner to lock it and prevent damage.

Removing the fittings

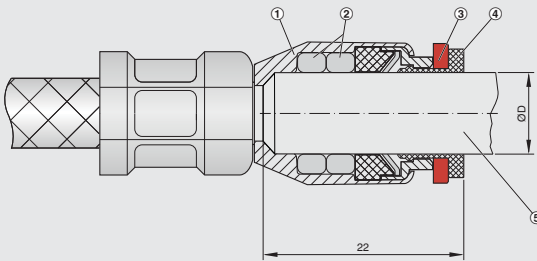

- ① Fitting
- ② Ring seal
- ③ Circlip
- ④ Opening ring
- ⑤ Pipe