



Explosion-proof fire damper

FKR-EU

according to Declaration of Performance
from DoP / FKR-EU / DE / 004



EPS 21 ATEX 2 141 X



II 2G Ex h IIC T5/T6 Gb
II 2D Ex h IIIC T95°C/T80°C Db
II 3G Ex h IIC T5/T6 Gc
II 3D Ex h IIIC T95°C/T80°C Dc

TROX[®] TECHNIK

The art of handling air

TROX GmbH
Heinrich-Trox-Platz
47504 Neukirchen-Vluyn
Germany
Phone: +49 (0) 2845 202-0
Fax: +49 (0) 2845 202-265
E-mail: trox-de@troxgroup.com
Internet: <http://www.troxtechnik.com>

Translation of the original
A00000038482, 2, GB/en
05/2023

© 2023

General information

Information on the supplementary operating instructions

This supplementary operating manual describes the explosion-protected fire damper in the variants:

- FKR-EU with fusible link
- FKR-EU with spring return actuator
ExMax-15-BF TR
- FKR-EU with spring return actuator
RedMax-15-BF TR

In order to ensure the complete function of the fire damper, it is necessary to read the supplementary operating instructions supplied before any use and to observe the instructions given therein. This supplementary operating manual must be handed over to the system operator when handing over the system. The system operator must attach the supplementary operating instructions to the system documentation.

Malfunctions or damage caused by non-observance of these supplementary operating instructions or by non-compliance with legal regulations do not lead to liability claims against the manufacturer.

This supplementary operating manual is intended for planners, installers and operators of ventilation systems in which the fire dampers are to be integrated. Furthermore, the supplementary operating instructions are intended for persons who carry out the following work:

- Electrical connection
- Commissioning
- Functional test

Other applicable documentation

In addition to this supplementary operating manual, the following documents must also be observed:

- Operating and assembly instructions FKR-EU
- ATEX certificate of conformity
EPS 21 ATEX 2 141 X

Symbols used in this manual

DANGER!

...indicates an imminently hazardous situation which, if not avoided, will result in death or serious injury.

WARNING!

...indicates a potentially hazardous situation which, if not avoided, may result in death or serious injury.

CAUTION!

...indicates a potentially hazardous situation which, if not avoided, may result in minor or moderate injury.

NOTICE!

...indicates a potentially dangerous situation that can lead to property damage if not avoided.

1	Safety	5
1.1	General safety notes	5
1.2	Correct use	5
2	Technical data	6
2.1	FKR-EU with fusible link, explosion proof version	6
2.2	FKR-EU with spring return actuator, explo- sion-proof	8
2.3	ATEX areas of application	9
3	Electrical connection	10
3.1	General safety notes	10
3.2	Potential equalisation	10
3.3	Ex limit switch for version with fusible link	10
3.4	Version with ExMax or RedMax spring return actuator	11
3.5	TROXNETCOM AS-i	11
4	Functional test	12
4.1	General Information	12
4.2	FKR-EU with fusible link and limit switch, explosion-proof version	12
4.3	FKR-EU with ExMax or RedMax spring return actuator	15

1 Safety

1.1 General safety notes

Only qualified personnel may carry out the described work on the fire damper. Only skilled qualified electricians are allowed to work on the electrical components.

The location must be easily accessible and have sufficient clearance for installation, electrical connection and maintenance of the fire damper.

Standards and guidelines

- Construction Products Regulation (EU) No. 305/2011
- EN 15650 - Ventilation for buildings - Fire dampers
- EN 13501-3 - Classification: Fire resistant ducts and fire dampers
- EN 1366-2 - Fire resistance tests for installations: Fire dampers
- EN 1751 Ventilation for buildings – Air terminal devices

The essential health and safety requirements of Directive 2014/34/EU are met by conformity with the following standards:

- EN 1127-1 - Explosive atmospheres - Explosion protection: Basic concepts and methodology
- DIN EN ISO 80079-36 - Explosive atmospheres: Non-electrical equipment for use in potentially explosive atmospheres - Basic concepts and requirements
- DIN EN ISO 80079-37 - Explosive atmospheres: Non-electrical equipment for use in potentially explosive atmospheres - Protection by constructional safety 'c

Repair and spare parts

The fire damper FKR-EU is a safety component specially developed for fire and explosion protection. To maintain its function, use only original TROX spare parts.

Note: Environmental protection

To protect the environment, please observe the following:

- The packaging of the fire damper must be disposed of in an environmentally sound manner.
- Used components or the used fire damper must be disposed of properly by an authorised service.
- Dispose of electronic components according to the local electronic waste regulations.

1.2 Correct use

- As a shut-off device, the fire damper prevents fire and smoke transmission through the air duct in explosion-protected areas.
- The fire damper may be used in supply air or extract air systems in areas with potentially explosive atmospheres.
- For the operation of the fire dampers, the installation instructions of the operating and installation instructions FKR-EU and the technical data of these supplementary operating instructions must be observed.

Use in areas with potentially explosive atmospheres (ATEX)

According to the certificate of conformity EPS 21 ATEX 2 141 X, the fire damper can be used in certain Ex zones. The ambient temperatures specified in the technical data as well as the release and actuation types must be observed, ↪ 2.3 'ATEX areas of application' on page 9 .

Incorrect use

The fire damper must not be used under the following conditions:

For the use

- as a smoke control damper,
- as a crossflow damper,
- outdoors without adequate protection against the effects of weather,
- in extract air systems of commercial kitchens,
- in ventilation systems in which the function is hindered by heavy soiling, extreme humidity or chemical contamination and
- in installation situations that prevent an internal inspection of the components of the installed fire damper.

Modifying the fire damper or using spare parts that have not been approved by TROX is not permitted.

Residual risks

TROX fire dampers are subject to strict quality controls during manufacturing. In addition, a functional test is performed before shipping.

Damage can, however, occur during transport or installation and impair the function of the fire damper.

In any case, the proper function of the fire damper must be checked during commissioning, and ensured through regular maintenance while in use.

2 Technical data

2.1 FKR-EU with fusible link, explosion proof version

Dimensions and weight

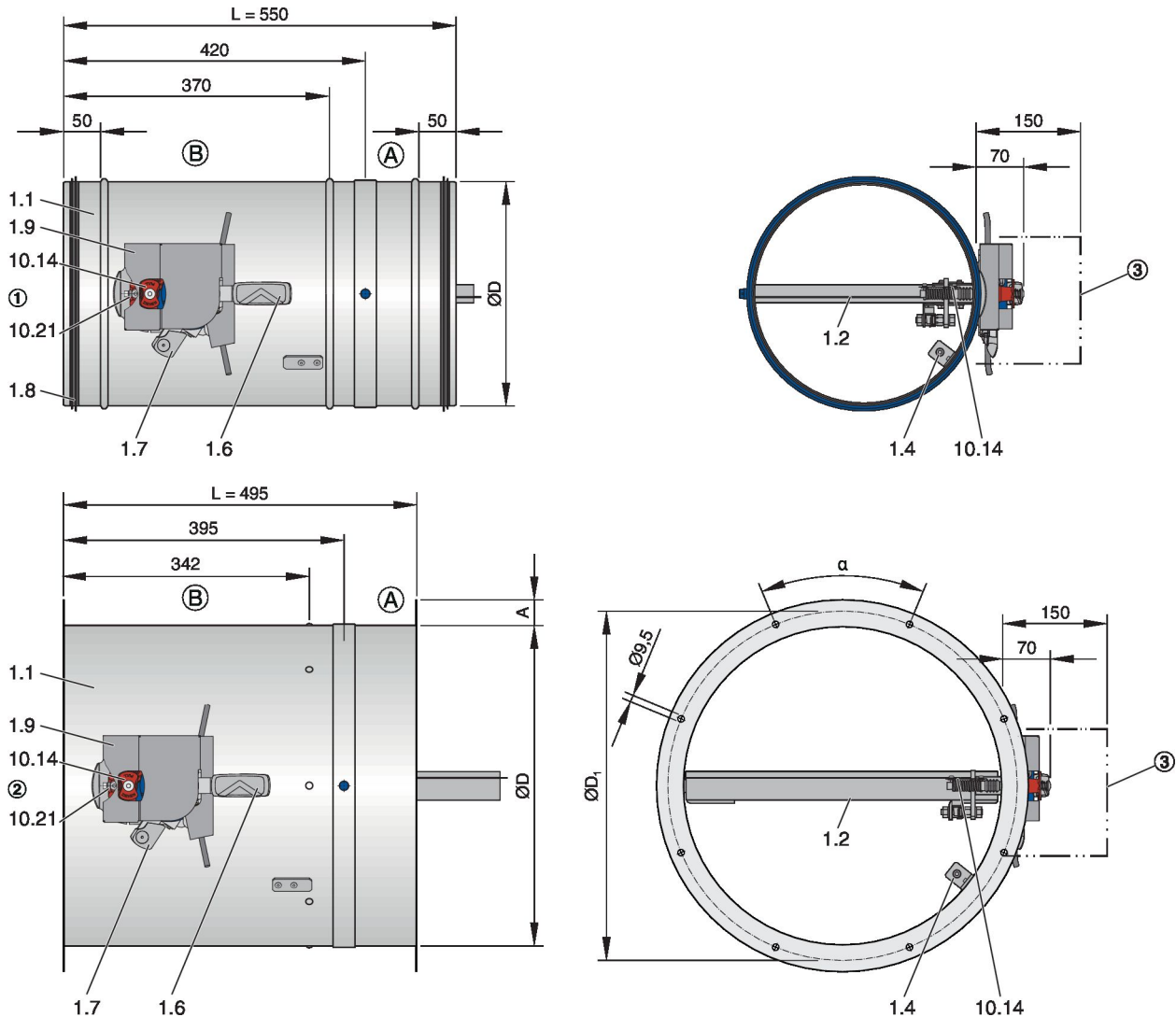

Fig. 1: FKR-EU with fusible link, explosion proof version

- | | | | |
|-----|---|-------|---|
| 1.1 | Casing | 10.14 | Thermal release mechanism with fusible link |
| 1.2 | Damper blade with sealing ring | 10.21 | Z-plate |
| 1.4 | Stop CLOSED position | 1 | Spigot construction |
| 1.6 | Handle | 2 | Flange construction |
| 1.7 | Interlock | 3 | Keep clear to provide access for operation |
| 1.8 | Lip seal | A | Installation side |
| 1.9 | Limit switch cover (only in case of limit switch) | B | Operating side |

Limit switch with fusible link Type 07-2511				
Connecting cable length / cross section		1 m / 3 × 0.75 mm ²		
Protection level		IP 66		
Type of contact		1 changeover contact		
Switch rating	Resistive load	250 V AC / 5 A	250 V DC / 0.4 A	30 V AC/DC / 7 A
	Inductive load cos φ = 0.6	250 V AC / 3 A	250 V DC / 0.03 A	30 V AC/DC / 5 A
Ambient temperature		-20 ... +50 °C		

The limit switches must be connected in a separately approved casing with an ignition protection according to EN 60079-0.

Dimensions [mm] / Weight [kg]									
Nominal size DN	315	355	400	450	500	560	630	710	800
∅D	314	354	399	449	499	559	629	709	799
A	31				36				
∅D ₁	352	392	438	488	538	600	670	750	840
α	45 °					30 °			22.5 °
No. of holes	8					12			16
Weight	6.8	7.3	8.5	14.1	16.4	18	21.3	25.7	28.6

2.2 FKR-EU with spring return actuator, explosion-proof

Dimensions and weight

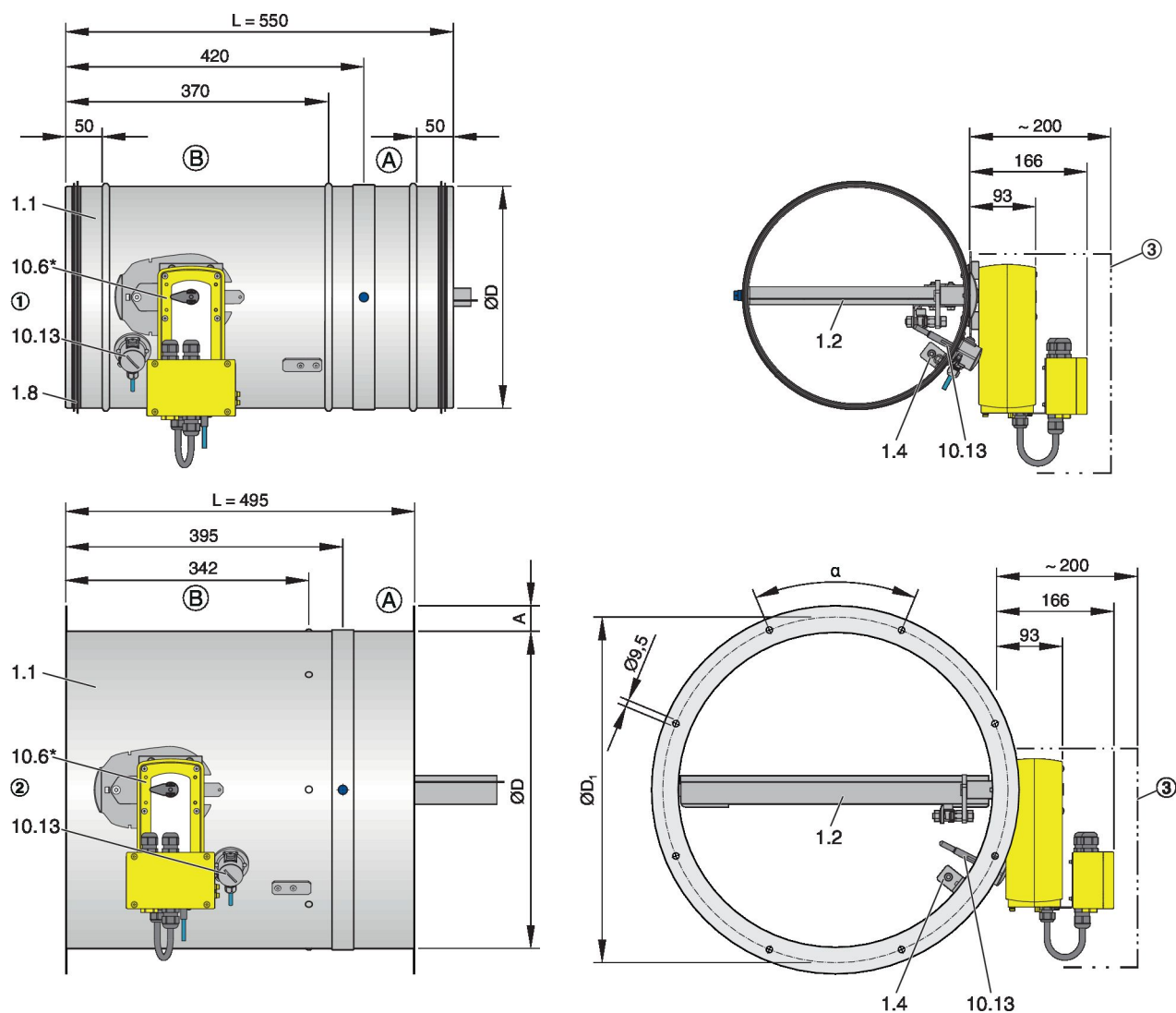

Fig. 2: FKR-EU with spring return actuator, explosion-proof







- | | | | |
|-------|--|-------|--|
| 1.1 | Casing | 10.13 | Thermoelectric release device ExPro-TT with temperature sensor |
| 1.2 | Damper blade with sealing ring | 1 | Spigot construction |
| 1.4 | Stop CLOSED position | 2 | Flange construction |
| 1.8 | Lip seal | 3 | Keep clear to provide access for operation |
| 10.6 | ExMax spring return actuator, alternatively* | A | Installation side |
| 10.7* | RedMax spring return actuator | B | Operating side |

Dimensions [mm] / Weight [kg]									
Nominal size DN	315	355	400	450	500	560	630	710	800
ØD	314	354	399	449	499	559	629	709	799
A	31				36				
ØD ₁	352	392	438	488	538	600	670	750	840
α	45 °				30 °			22.5 °	
No. of holes	8				12			16	
Weight	10.2	10.7	11.9	17.4	19.7	21.3	24.6	29.0	31.9

Spring return actuator type ExMax-15-BF TR / RedMax-15-BF TR		
Supply voltage	24 - 240 V AC/DC, ± 10 % each, self-adaptive 50 - 60 Hz ± 20 %	
Power rating	16 W / 15 VA	
Switch-on current (< 1 s)	2 A	
Run time	Actuator / spring return	30 s / 10 s
Limit switch	Type of contact	2 changeover contact
	Switching voltage	230 V AC / 24 V DC
	Switching current	0.4 mA – 3 A
IEC protection class / IP protection		I (earthed) / IP66
Storage temperature		-40 ... +55 °C
Ambient humidity		≤ 90% rh, non-condensing

2.3 ATEX areas of application

ATEX application ranges, depending on the type of release mechanism, actuation, ambient temperature and airflow velocity

Release mechanism	Type of actuation	Labelling	Ambient temperature	Maximum airflow velocity
Fusible link	Spring mechanism	 II 2G Ex h IIC T6 Gb II 2D Ex h IIIC T80°C Db	-40 °C ≤ Ta ≤ +50 °C	8 m/s
Fusible link and limit switch	Spring mechanism	 II 2G Ex h IIC T6 Gb II 2D Ex h IIIC T80°C Db	-20 °C ≤ Ta ≤ +50 °C	8 m/s
ExPro-TT	ExMax-15-BF TR	 II 2G Ex h IIC T6 Gb II 2D Ex h IIIC T80°C Db	-40 °C ≤ Ta ≤ +40 °C	10 m/s
ExPro-TT	ExMax-15-BF TR	 II 2G Ex h IIC T5 Gb II 2D Ex h IIIC T95°C Db	-40 °C ≤ Ta ≤ +50 °C	10 m/s
ExPro-TT	RedMax-15-BF TR	 II 3G Ex h IIC T6 Gc II 3D Ex h IIIC T80°C Dc	-40 °C ≤ Ta ≤ +40 °C	10 m/s
ExPro-TT	RedMax-15-BF TR	 II 3G Ex h IIC T5 Gc II 3D Ex h IIIC T95°C Dc	-40 °C ≤ Ta ≤ +50 °C	10 m/s

Ex limit switch for version with fusible link

3 Electrical connection

3.1 General safety notes

⚠ DANGER!

Danger of electric shock! Do not touch any live components! Electrical equipment carries a dangerous electrical voltage.

- Only skilled qualified electricians are allowed to work on the electrical system.
- Switch off the power supply before working on any electrical equipment.

Observe the VDE guidelines for connection work!

3.2 Potential equalisation

To prevent ignition sources due to static charging, the fire damper must be integrated into the potential equalisation of the ventilation system.

Execution of potential equalisation (on-site):

- Single-wire CU cable 4 mm² with ring cable lug.

Connection options for potential equalisation:

- Fire damper with ExMax / RedMax spring return actuator
 - Terminal box to terminal PA
- Fire damper with fusible link
 - Flange version: fixing screws (M8) on the inside of the flange, or drilling screw on the flange
 - Spigot version: Screw (1) Fig. 3 on release device

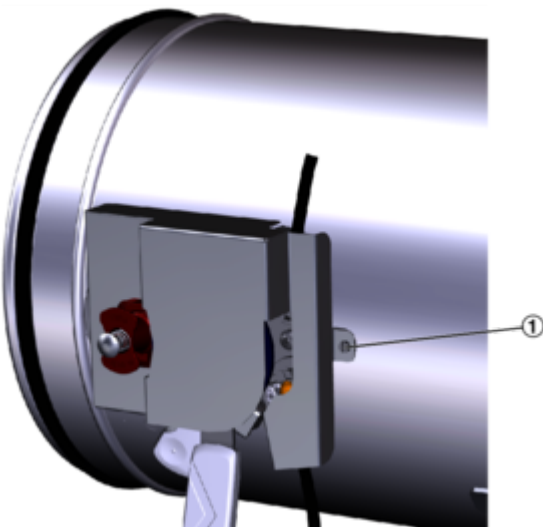

Fig. 3: FKR-EU Potential equalisation connection

3.3 Ex limit switch for version with fusible link

Connection of the Ex limit switches acc. to the wiring example (see figure). The limit switches must be connected in a separately certified casing of a recognised type of protection according to EN 60079-0.

Indicator lights or relays may be connected as long as the performance specifications are taken into consideration.

The EX limit switches can be used as "NO normally open" or "NC normally closed" contacts for signalling.

Connection example Ex limit switch

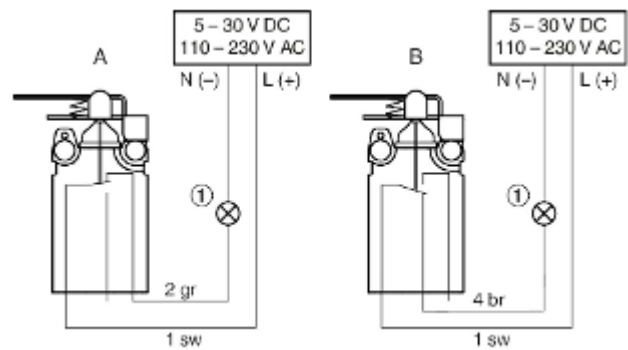

Fig. 4: Connection example Ex limit switch

- 1 Indicator light or relay, to be provided by customer
- A Connection type NC contact
- B Connection type NO contact

Connection type	Limit switch	Damper blade	Electric circuit
A	not actuated	CLOSED or OPEN position <u>not reached</u>	closed
B	actuated	CLOSED or OPEN position reached	closed

3.4 Version with ExMax or RedMax spring return actuator

The ExMax or RedMax spring return actuator has automatic voltage detection 24 V - 240 V AC/DC. The actuator detects the voltage automatically and does not have to be adjusted.

Connect the spring return actuator according to the wiring example.

Several actuators can be connected in parallel, as long as the performance specifications are taken into consideration.

Functional testing requires a switch that interrupts the voltage supply (to be provided by customer).

The electrical connection is made in the terminal box. The factory wiring must not be changed.

Attention!

If interrupted via the switch (1) or the optional release device (2), the heating (6) is not active.

Connection example ExMax or RedMax spring return actuator

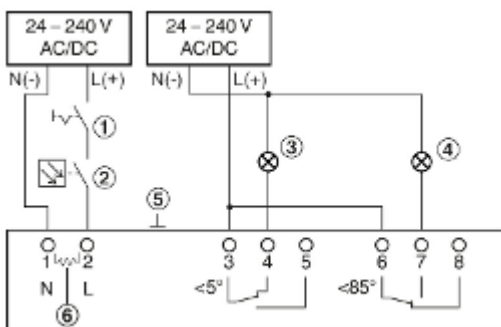

Fig. 5: Connection example Ex actuator

- 1 Switch for opening and closing, to be provided by customer
- 2 Optional release device, e.g. TROX duct smoke detector type RM-O-3-D or RM-O-VS-D (outside the Ex area)
- 3 Indicator light for CLOSED position, to be provided by customer
- 4 Indicator light for OPEN position, to be provided by customer
- 5 Connection terminal for potential equalisation 4 mm²
- 6 Heating

3.5 TROXNETCOM AS-i

The fire dampers with spring return actuator and the accessory AS-EM/C module form a functional unit for BUS communication for fire damper control.

The module must be mounted and wired outside the Ex zone by the customer.

- The module transmits the control signals between the spring return actuator and the controller unit. This enables the control the actuator and monitoring the actuator's run time during function tests.
- The 24 V DC supply voltage for the module and the actuator is transmitted using the AS-i flat ribbon cable.
- Function display:
 - Operation
 - 4 inputs
 - 2 outputs

TROXNETCOM connection example

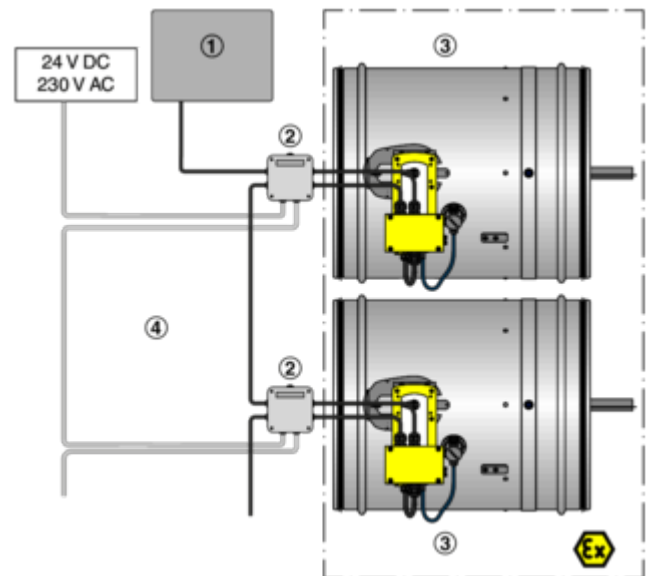

Fig. 6: TROXNETCOM connection example

- 1 Controller
- 2 AS-EM/C module
- 3 FKREU
- 4 Safe area

4 Functional test

4.1 General Information

During operation, the fire damper is open. A functional test involves closing and opening the damper blade. The procedure differs depending on the type release mechanism.

WARNING!

During the release, there is a risk of injury when reaching into the release device or into a moving damper blade. Do not touch the release device or the fire damper blade while actuating the release mechanism.

4.2 FKR-EU with fusible link and limit switch, explosion-proof version

NOTICE!

The Z-plate (Fig. 1 /10.21) is an important component of the ATEX version of the FKR-EU with fusible link, which ensures a conductive connection between the thermal release device and the fire damper casing.

When installing the thermal release device on the fire damper casing, be sure to insert one of the two fixing screws into the circular hole of the Z-plate.

When removing the thermal release device (↘ FKR-EU operating and assembly instructions), check that the Z-plate is intact. If damaged, replace the entire thermal release device.

The Z-plate must not be changed or removed.

Damper blade position indicator

The position of the damper blade (1.2) is indicated by the vertical or horizontal position of the handle (1.6).

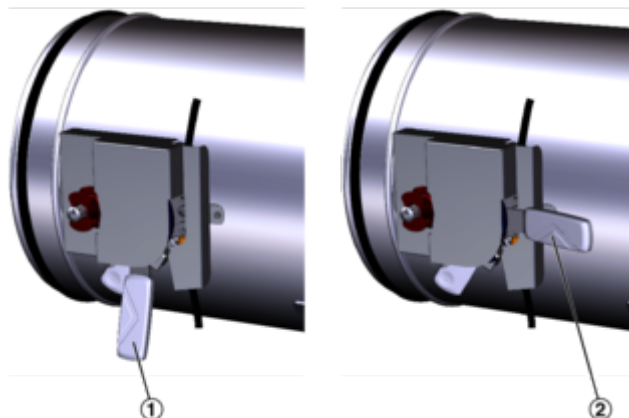
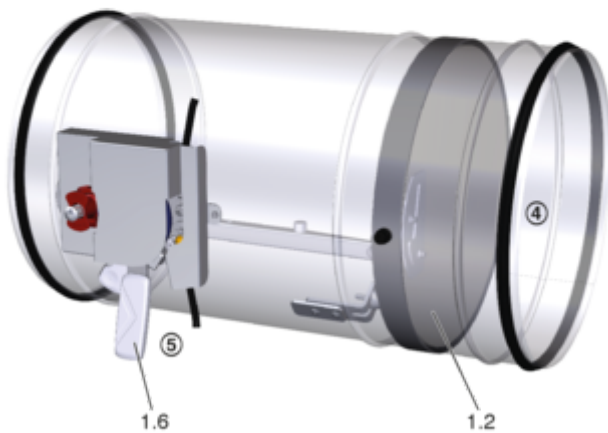
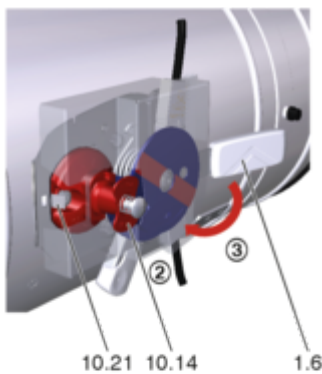
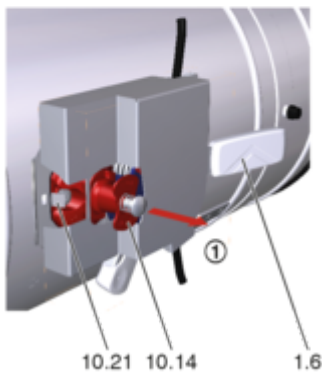
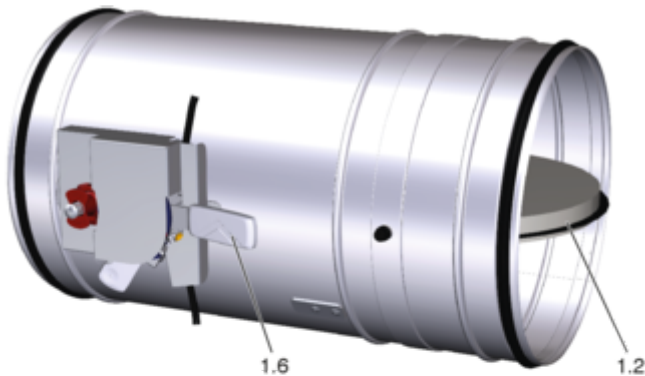

Fig. 7: Damper blade position indicator

1. ▶ Damper blade (1.2) closed.
2. ▶ Damper blade (1.2) open.

Close the damper blade**Requirement**

- The damper blade is OPEN.
1. ▶ Pull the hand knob of the thermal release device (10.14) forward in the direction of the arrow to
 2. ▶ Release the cam disc (1.6) of the handle.
 3. ▶ The handle (1.6) swivels automatically in the direction of the arrow.
 4. ▶ The damper blade (1.2) engages in the CLOSED position and
 5. ▶ The handle (1.6) indicates that the damper blade (1.2) is closed.

Fig. 8: Close the damper blade

Opening the damper blade

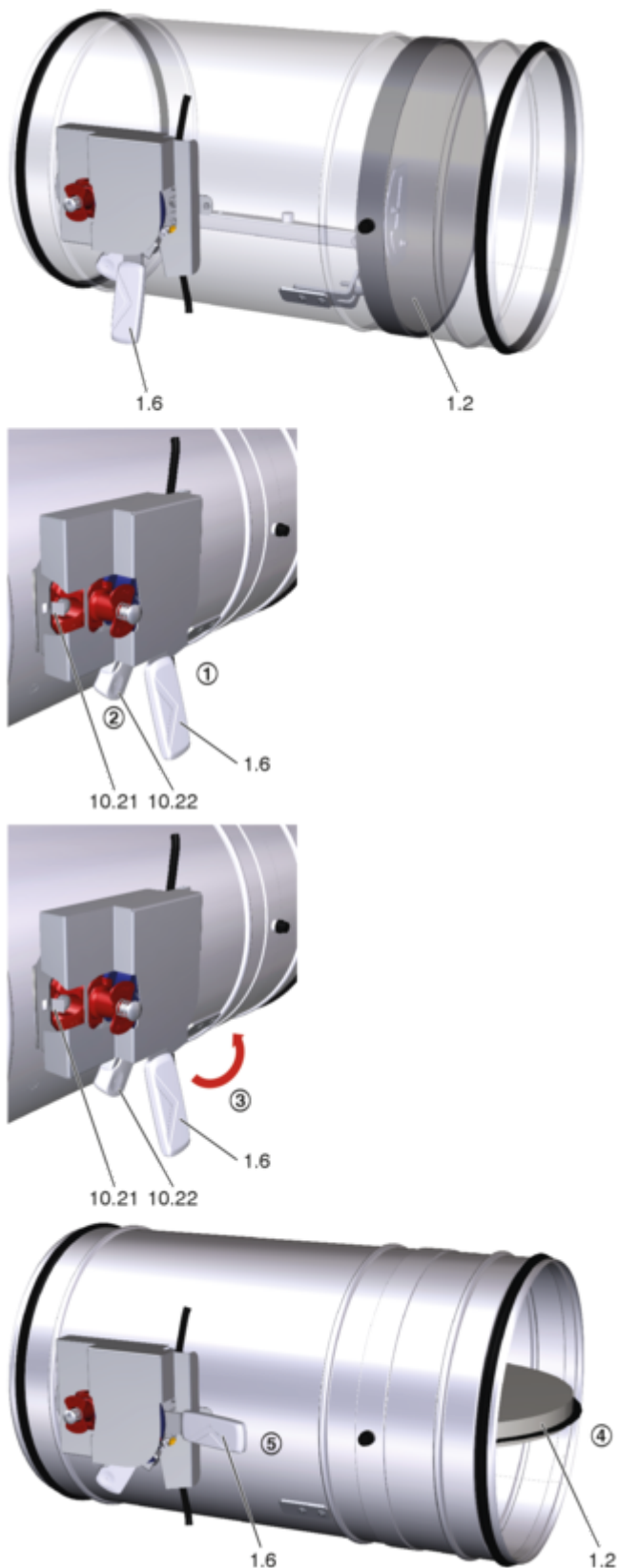

Requirement

- The damper blade is CLOSED.
1. ▶ Grasp the handle (1.6) with one hand and
 2. ▶ Press the release (10.22) with the thumb.
 3. ▶ Turn the handle (1.6) in the direction of the arrow until the stop.
 4. ▶ The damper blade (1.2) engages in the OPEN position and
 5. ▶ The handle (1.6) indicates that the damper blade (1.2) is open.

Fig. 9: Opening the damper blade

4.3 FKR-EU with ExMax or RedMax spring return actuator

Damper blade position indicator

The position of the damper blade is indicated by the pointer on the actuator.

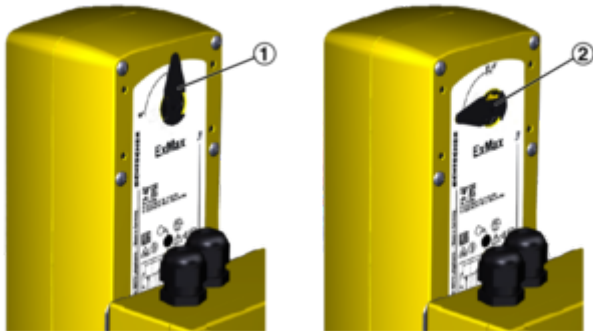

Fig. 10: Damper blade position indicator

- 1 Damper blade is closed
- 2 Damper blade is open

Closing/opening the fire damper with spring return actuator



Fig. 11: Thermoelectric release mechanism ExPro-TT

- 1 Push button for functional test

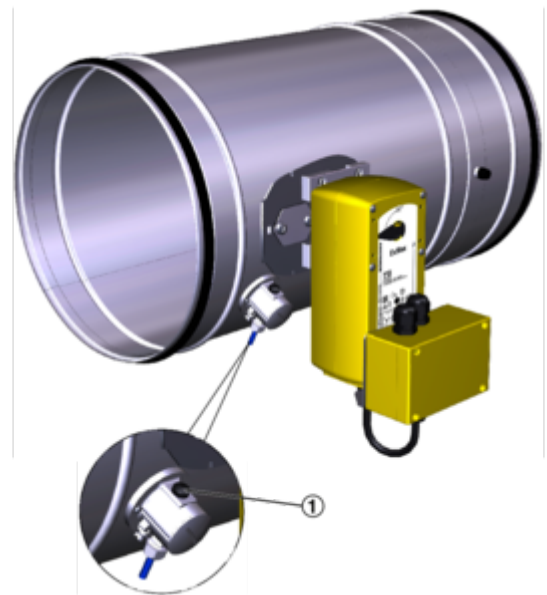

Fig. 12: Functional test (FKR-EU with ExMax actuator shown in OPEN position)

⚠ CAUTION!

Danger of injury when reaching into the fire damper while the damper blade is moving. Do not reach into the fire damper while actuating the release mechanism.

Requirement

- Power is being supplied
- 1. ▶ Push the push button (1) and keep it pushed.
 - ⇒ This interrupts the power supply, and the damper blade closes.
- 2. ▶ Check if the damper blade is CLOSED, check run time.
- 3. ▶ Release the push button (1).
 - ⇒ Power is supplied again, and the damper blade opens.
- 4. ▶ Check if the damper blade is OPEN, check run time.

Opening/closing the fire damper using the crank handle

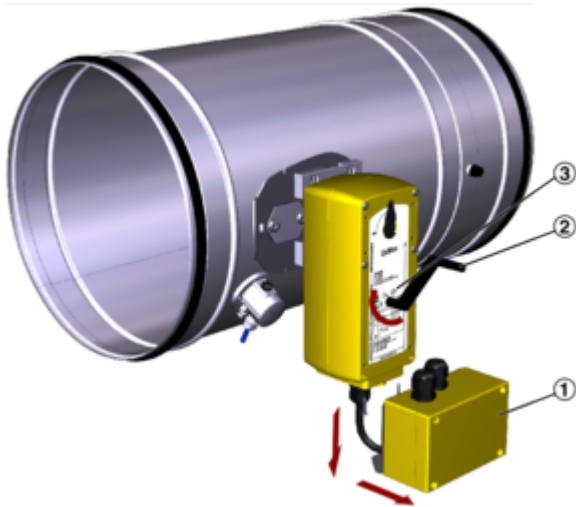

Fig. 13: Functional test (without power supply)

DANGER!

Danger due to malfunction of the fire damper.

If the damper blade has been opened by means of the crank handle (without power supply), it will no longer be triggered by a temperature increase, i.e. in the event of a fire. In other words, the damper blade will not close.

To re-establish its function, connect the power supply.

Requirement

- The damper blade is CLOSED
- 1. ▶ Remove the terminal box (1).
- 2. ▶ Insert the crank handle (2) into the opening for the spring-winding mechanism (The crank handle is clip-fixed to the connecting cable.)
- 3. ▶ Turn the crank handle (2) in the direction of the arrow (3) to the travel stop.
- 4. ▶ Remove the crank handle (2).
 - ⇒ The damper blade (1.2) will then CLOSE.
- 5. ▶ Mount the terminal box (1).

TROX[®] TECHNİK

The art of handling air

TROX GmbH
Heinrich-Trox-Platz
47504 Neukirchen-Vluyn
Germany

Phone: +49 (0) 2845 202-0
+49 (0) 2845 202-265
E-mail: trox-de@troxgroup.com
<http://www.troxtechnik.com>

© 2023